

Overcoming RF Signal Generation Challenges in Quantum Computing with New DAC Technologies

WHITE PAPER

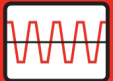
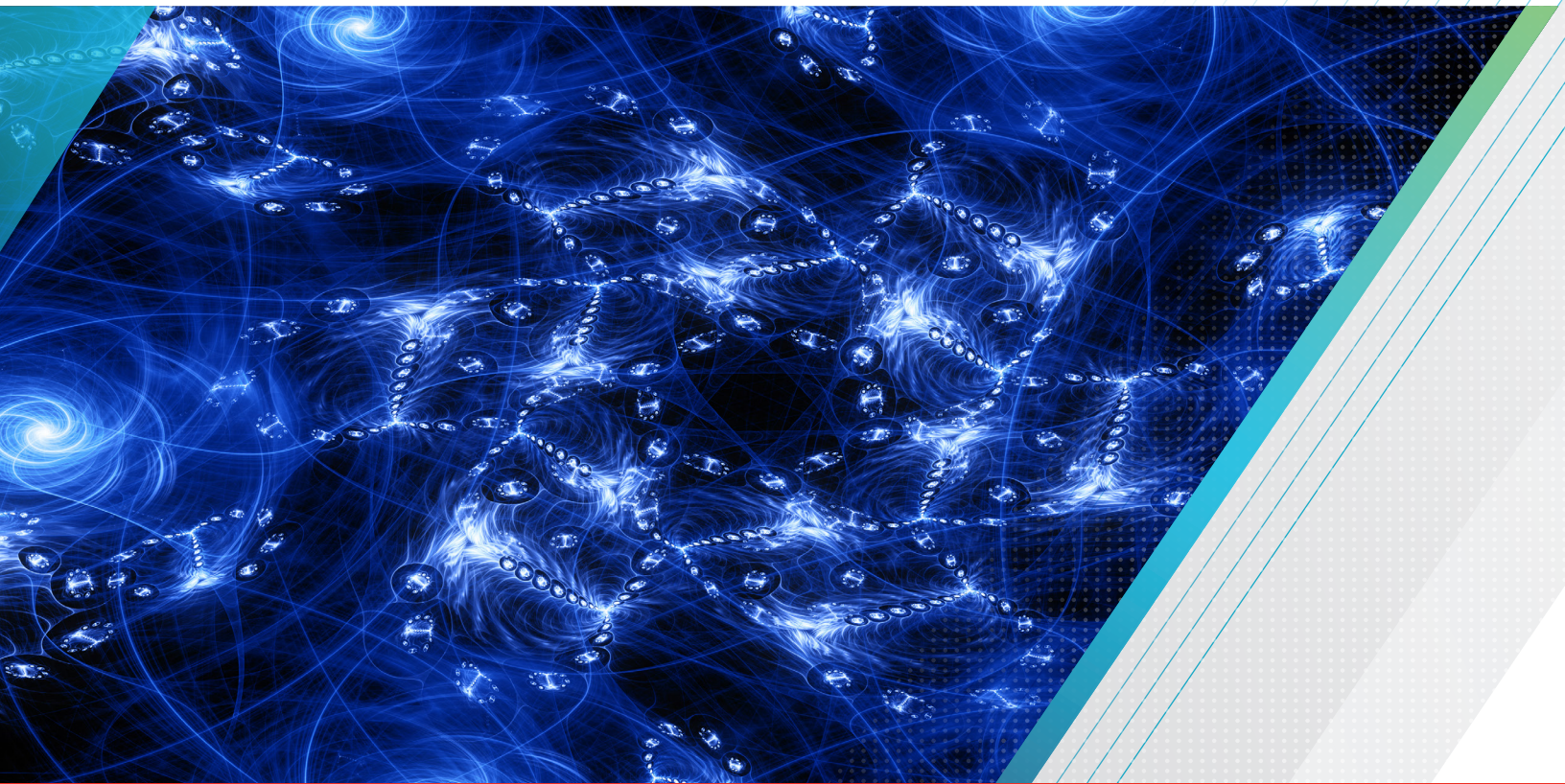

S J ELECTRONICS
POWER • TEST & MEASUREMENT

☎ 0800 583 4455

✉ sales@sjelectronics.co.uk

[VISIT WEBSITE](#)

Tektronix[®]

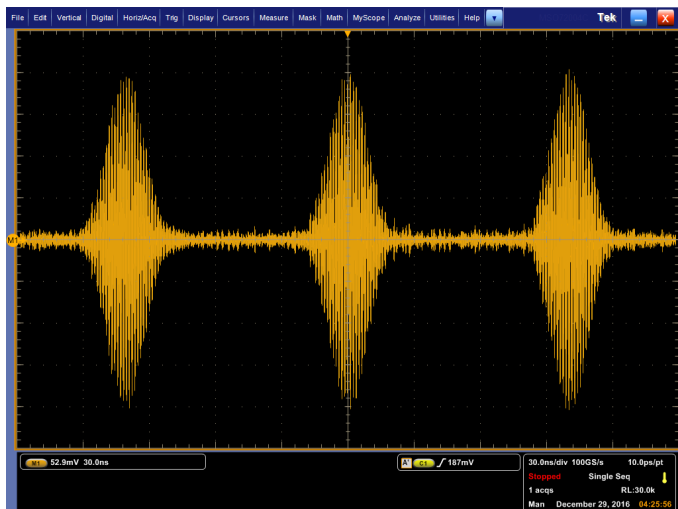

Contents

- Introduction to Microwave Complex Signal Generation3
- High-speed DAC's with Digital Complex Modulators3
- Direct Signal Generation in the Higher Order Nyquist Bands4
- Superheterodyne Up-Conversion Using the NCO and an External Mixer8
- Conclusion10
- Bibliography10

Abstract

Modern RF systems like superconducting quantum bit controllers, phased-array radar, MIMO transceivers, smart antenna transmitters, and agile ultra-wideband spread spectrum telecommunication are based on wideband, coherent, multi-channel architecture. The traditional method using vector signal generators with IQ modulators and analog synthesizers for RF signal generation pose major limitations due its calibration complexity and cost for large-scale implementation of such systems. As a solution to this, a class of high-speed digital-to-analog converters is emerging that embody signal processing, modulation, and generation functionalities. These data converters are capable of directly synthesizing complex signals at microwave frequencies. They also allow for simpler multi-channel synchronization and calibration and offer a significantly lower cost for systems with high channel density by eliminating the need for complex analog front-end. For example, Tektronix AWG5200 series arbitrary waveform generators utilize such digital-to-analog converters and offer up to 8 synchronized channels per instrument that is further expandable by synchronizing more instruments.

In this document, some important features enabling the AWG5200 series for direct RF complex signal generation are presented followed by a discussion on two architectural techniques that can be implemented externally to further expand the frequency coverage of the instrument with a focus on reducing cost and complexity for multi-channel applications.

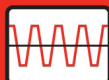

Introduction to Microwave Complex Signal Generation

A common method to generate complex signals is to modulate a carrier signal with frequency f_c generated by a local oscillator (LO) using a vector modulator that is a hardware implementation of the following trigonometric identity:

Eq. 1

$$I \cos(\omega_c t) + Q \sin(\omega_c t) = A \sin[\omega_c t + \Phi]$$

Where, $\omega_c = 2\pi f_c$, $A = \sqrt{I^2 + Q^2}$, and $\Phi = \tan^{-1} \frac{Q}{I}$. This formula can conveniently be implemented in hardware by noting that $\sin(\omega_c t) = \cos(\omega_c t + \pi/2)$ which implies that by shifting the phase of the carrier signal by 90 degrees the sine and cosine terms to left hand side of Eq. 1 can be produced from a single sinusoidal source. The I and Q terms are the in-phase and quadrature baseband signals respectively that can set the amplitude and phase of the carrier signal to any arbitrary value which makes this a powerful modulation technique capable of producing any type of modulation.

For RF and microwave applications, generation of the I and Q signals are typically done using arbitrary waveform generators (AWG) where at their core they contain two (or more) synchronized digital to analog converters (DAC). Figure 1 shows a two-channel AWG supplying the I and Q signals to a vector signal generator (VSG).

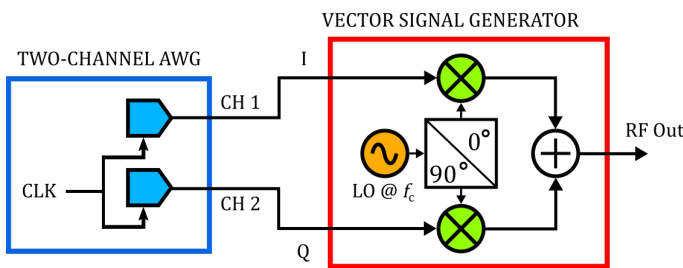

FIGURE 1. RF complex signal modulation using a two-channel arbitrary waveform generator and a microwave vector signal generator.

A disadvantage of this technique is that the signal modulation quality is degraded due to the amplitude and phase imbalance of the I and Q signals and the LO leakage. This is due to hardware non-idealities of the vector modulator [1] [2] which can, to some extent, be compensated and corrected through a series of calibration operations [3]. Also with this signal generation method, the cost and complexity grows rapidly for large-scale, multi-channel RF systems. For example, in a superconducting quantum bit (qubit) controller system where the frequency of the carrier pulsed signals used for excitation of qubit resonators need relative fine tuning, each RF channel would include a VSG with independent tunable LO and two channels of an AWG. Additionally, the LO leakage limits the dynamic range in pulsed signal applications where a stable, high on-to-off ratio is needed.

In the following sections, two alternative microwave signal generation techniques are discussed based on direct modulated waveform generation at high frequencies using modern high-speed AWG's. Compared to the VSG based method, these techniques offer a simpler and more cost-effective hardware implementation for systems with high channel density.

High-speed DAC's with Digital Complex Modulators

Reducing the size and cost for telecommunication and military systems is driving the evolution of modern DAC's to integrate more functionalities into a single chip. Some of the more advanced high-speed DAC's also incorporate digital signal processing and conditioning functionalities such as FIR filters, digital interpolation [4], complex modulation, and numerically controlled oscillators (NCO) [5]. This enables direct generation of complex RF signals in an efficient and compact way. Figure 2 shows the simplified block diagram for the high-speed 16-bit DAC used in Tektronix AWG5200 series featuring digital complex modulator and multi-rate interpolation.

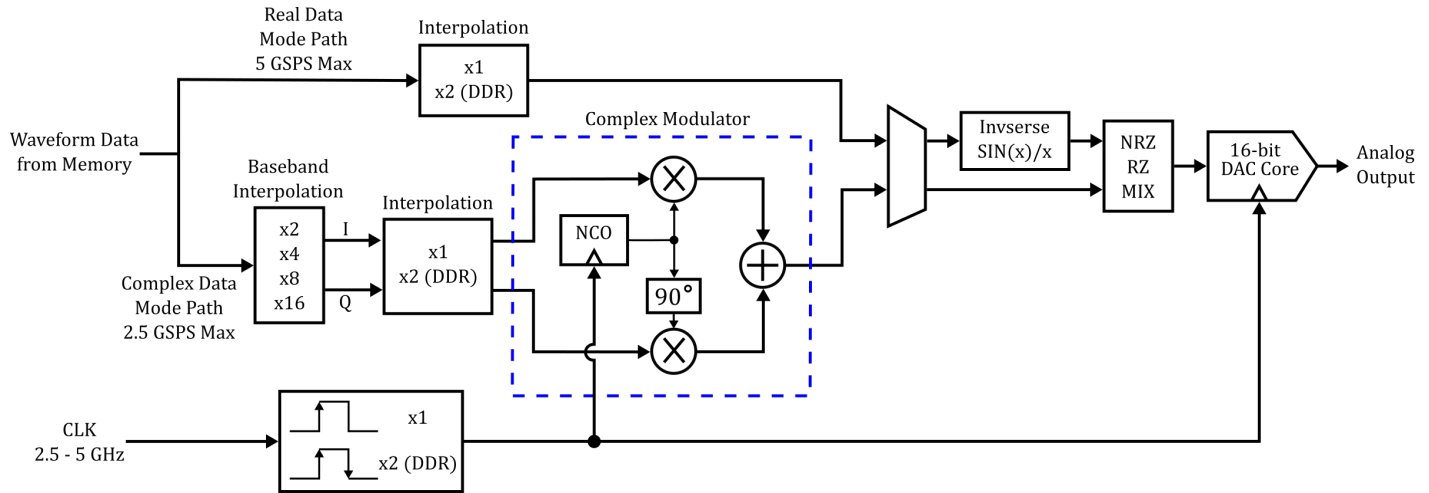

FIGURE 2. Simplified block diagram of the AWG5200 Series DAC.

The complex modulator is the digital implantation of a vector signal generator. The NCO acts as the local oscillator providing the carrier signal and the user-defined I and Q baseband signals are digitally streamed into the DAC from an off-chip memory. The output of this modulator is a digital waveform applied to the DAC core. The frequency of the NCO is controlled using a dedicated on-chip register and it can be independently programmed allowing for the carrier frequency to be tuned without recalculating or reloading of the I-Q waveforms. Interpolation in the digital data path provides a means for the waveform data to be generated and supplied to the DAC at lower sample rates which requires fewer samples for the waveforms resulting in less memory consumption. Two independent interpolation blocks are included, a baseband block with selectable factors from x2 to x16, and a block associated with the Double Data Rate (DDR) clocking feature. When DDR is off, the data is converted only on one of the clock edges and the interpolation mode is set to x1 while in double data rate (DDR) mode the data is x2 interpolated and it is converted on both edges of the clock signal. Also in DDR mode, the NCO's sample rate doubles. This means that at the maximum clock frequency of 5GHz the NCO and the DAC core are running at sample rate of 10GSPS and carrier frequencies up to 5GHz in the first Nyquist band can be synthesized.

With a reconstruction filter (a low-pass filter with cut-off frequency at $f_{\text{sample rate}}/2$) at the output of the AWG5200 series, analog signals with complex modulation can be directly generated up to nearly 5GHz. Signals at higher frequencies are also possible by utilizing the higher order Nyquist bands.

Direct Signal Generation in the Higher Order Nyquist Bands

The time-domain output signal generated by a DAC that approximates an ideal analog signal $x(t)$ can mathematically be expressed by the following convolution series:

$$\text{EQ. 2} \quad y(t) = \sum_{N=-\infty}^{+\infty} \Pi_{T_s}(t) * x(t) \delta(t - NT_s)$$

Where * is the convolution operator, $T_s = \frac{1}{f_s}$ is the sampling period, $\Pi_{T_s}(t)$ is a rectangular function of unity magnitude centered at $t = 0$ and bounded by $[-\frac{T_s}{2}, \frac{T_s}{2}]$, and δ is the Dirac delta function. The convolution of delta functions scaled by $x(t)$ with $\Pi_{T_s}(t)$ produces DAC scaled copies of the rectangular function in time at instances where $t - NT_s = 0$. Figure 3 shows an analog signal being approximated by a DAC with sample rate of $f_s = 1/T_s$ samples per second along with a series of delta functions repeated every T_s seconds and scaled by $x(t)$.

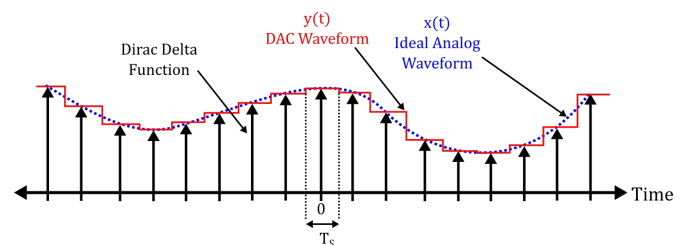

FIGURE 3. An ideal analog signal $x(t)$ approximated by a DAC with sample rate of $f_s = \frac{1}{T_s}$ SPS.

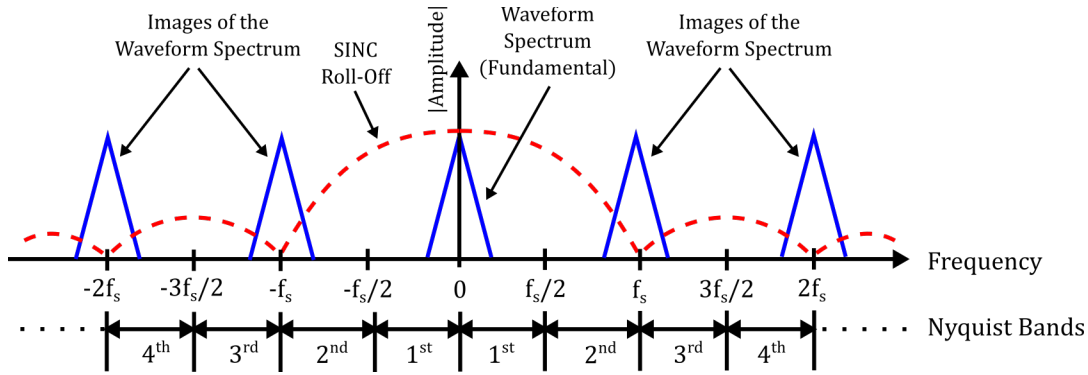

FIGURE 4. Magnitude of the complex output spectrum of a DAC with sample rate of f_s .

To analyze the frequency response of a DAC, we take the Fourier transform of Eq. 2, $\mathcal{F}\{y(t)\}$, that is given by:

EQ. 3

$$Y(\omega) = 2\pi \operatorname{sinc}\left(\frac{\omega}{2} T_s\right) \sum_{K=-\infty}^{+\infty} X(\omega) * \delta(\omega - K\Omega_s)$$

Where $\omega = 2\pi f$, $\Omega_s = \frac{2\pi}{T_s}$, $\operatorname{sinc}\left(\frac{\omega}{2} T_s\right)$ is the SINC function defined by $\frac{\sin\left(\frac{\omega}{2} T_s\right)}{\frac{\omega}{2} T_s}$, and $X(\omega) = \mathcal{F}\{x(t)\}$. The convolution

series term $X(\omega) * \delta(\omega - K\Omega_s)$ means that $X(\omega)$ is repeated every integer multiple of the sampling frequency. The SINC function imposes an amplitude roll-off with nulls at integer multiple of the sampling frequency.

Figure 4 shows the magnitude of the complex output spectrum of a DAC generating an arbitrary waveform. It can be seen that in every half sample rate intervals there is an image of the waveform spectrum. These intervals are referred to as the Nyquist bands and the spectrum is inverted in even-order bands. By applying the appropriate analog filter and amplifier to the output of the DAC, these images can be used to directly generate signals at higher frequencies; however, the limitations imposed by the SINC roll-off of the amplitude should be taken into account. Figure 5 shows the normalized frequency response of an ideal DAC outputting a sine waveform with the frequency of $0.3f_s$ and its images at $0.7f_s$, $1.3f_s$, and $1.7f_s$.

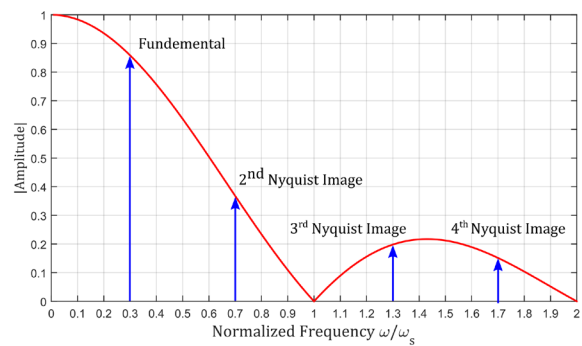

FIGURE 5. Normalized frequency response of an ideal DAC.

In addition to the SINC roll-off, which is an inherent property of DAC's, the frequency response of an AWG is also affected by IC package parasitics, added components, devices, and interconnects along the analog path. Figure 6 shows the typical frequency response of the output power of the AWG5200 series running at maximum sample rate of 10GSPS and its deviation from the ideal DAC response.

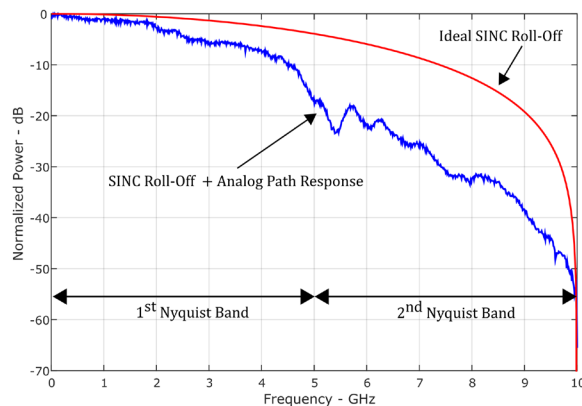

FIGURE 6. Frequency response of the output power of AWG5200 series at maximum sample rate, 10GSPS. The power measurement is normalized to the peak value at -3dBm.

Other consideration factors for direct signal generation in the higher order Nyquist bands are the noise floor of the DAC and spurious products that could limit the dynamic range [6]. Figure 7 shows the output power spectrum measurement in the 1st and 2nd Nyquist bands of the AWG5200 series configured with sample rate of 7GSPS for a swept single-tone signal over a 300MHz range. This signal was generated by sweeping the NCO frequency from 1.85GHz to 2.15GHz which produced an image centered at 5GHz. This measurement also shows other spurious products generated by the instrument's DAC due to its hardware non-idealities.

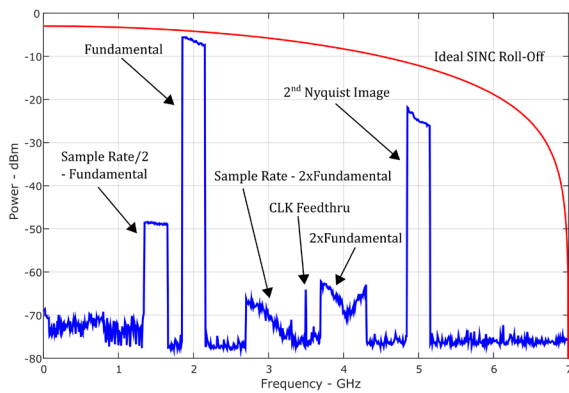

FIGURE 7. Power spectrum measurement for a single-tone swept from 1.85GHz to 2.15GHz with sample rate of 7GSPS producing the 2nd Nyquist image centered at 5GHz.

The power spectrum measurement of the 2nd Nyquist image with the spectrum analyzer configured for lower noise floor is shown in Figure 8. Despite having a lower amplitude level with respect to the fundamental signal, this image has a dynamic range of 56dB within 1GHz span which allows for a practical band-pass filter centered at 5GHz to utilize the image in the 2nd Nyquist band. For larger amplitude levels, a gain stage comprised of one or more amplifiers can follow the filter as shown in Figure 9. It is important for the filter to be placed at the input of the gain stage to prevent the power of the undesired spectral components from overdriving the amplifier and also to minimize the effects of intermodulation on the dynamic range due to amplifier's non-linearity.

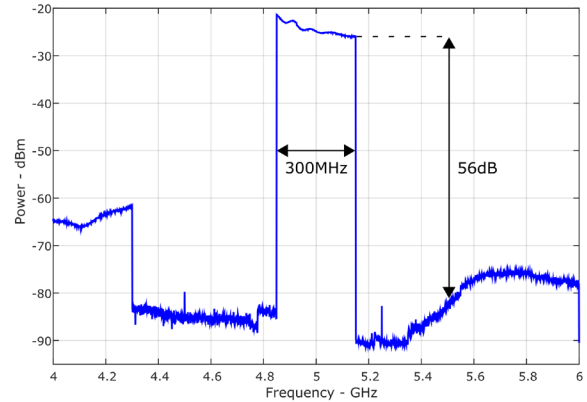

FIGURE 8. High dynamic range power spectrum measurement of The 2nd Nyquist image of a sweep from 1.85GHz to 2.15GHz with the sample rate of 7GSPS.

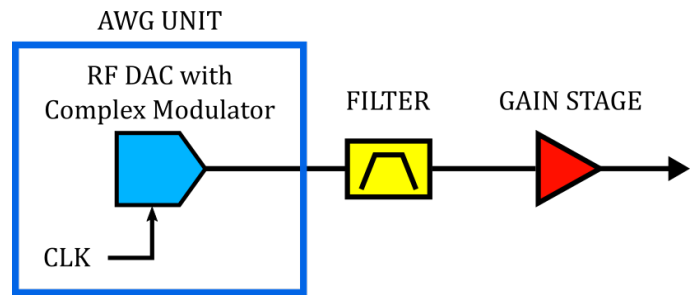

FIGURE 9. External filtering and amplification of the 2nd Nyquist image.

Similarly, signals with complex modulation with carrier frequency, f_c , in the 2nd Nyquist band can be generated using the internal digital modulator of the AWG by setting the NCO frequency to $f_s - f_c$. The spectrum mirroring of the image with respect to the fundamental signal can be corrected by taking the complex conjugate of the I-Q signals. This simply means inverting the sign of the time-domain Q waveform.

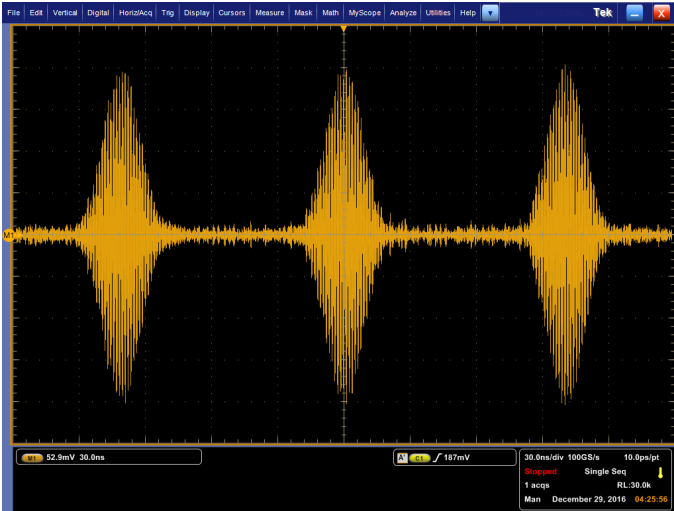

FIGURE 10. Time-domain measurement of a 20ns-wide Gaussian pulse with carrier frequency of 5GHz in the 2nd Nyquist band. A 350MHz-wide digital band-pass filter with 256 taps was used in the oscilloscope to filter out the fundamental and other spurious products.

Figure 10 shows the time-domain measurement of the 2nd Nyquist image of a 20ns Gaussian pulse created using complex modulation with the sign of the Q baseband waveform inverted. The AWG clock was set to 3.584GHz, the DDR mode enabled, and the baseband waveform data

interpolated by 2x which sets the sample rate of the I and Q waveforms to 1.792GSPS and the final sample rate to 7.168GSPS. The NCO frequency was set to 2.168GHz which produced the 2nd Nyquist image centered at 5GHz. For this measurement, no external filter or amplifiers were used but the acquired waveform was post-processed by applying a 350MHz-wide digital FIR band-pass filter centered at 5GHz to remove the fundamental signal.

The amplitude and phase distortion due to the composite frequency response of the AWG and the external components can be compensated by applying FIR filter to the I and Q waveforms in the digital domain. The pre-compensation software plug-in for the AWG5200 series provides an automated method to characterize the frequency response of the AWG along with any added external components over a given center frequency and bandwidth and subsequently generates the FIR filter coefficients. Reference [7] provides more details on this subject. Figure 11 shows the pre-compensation filter applied to a multi-tone waveform in the 2nd Nyquist band centered at 5GHz. This waveform was also created using the complex modulator with the same AWG setting as the aforementioned Gaussian pulse.

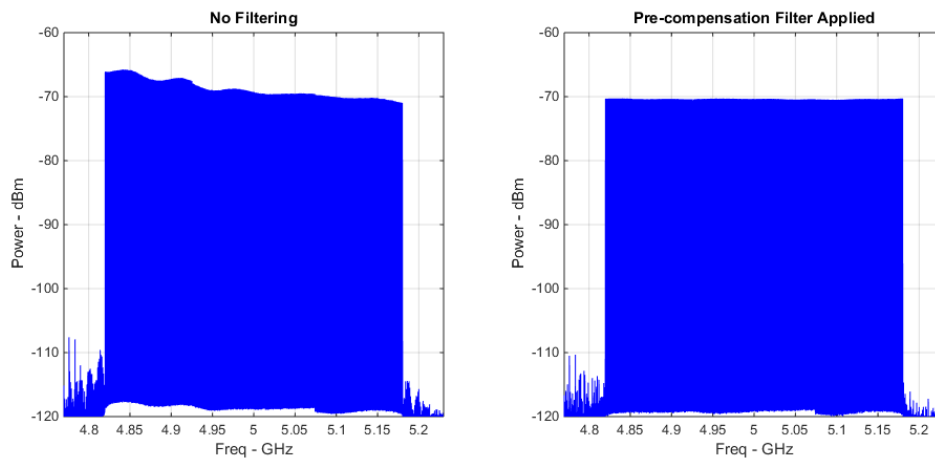

FIGURE 11. Power spectrum measurement of a multi-tone waveform in the 2nd Nyquist band comprised of 361 tones with 1MHz spacing from 4.82GHz to 5.18GHz without filtering (left) and with digital pre-compensation filter applied (right).

Superheterodyne Up-Conversion Using the NCO and an External Mixer

In cases where the desired frequency is too high to utilize the higher order Nyquist bands effectively and with good dynamic range, a superheterodyne up-conversion scheme using the NCO and an external mixer [8] can be implemented to extend the output frequency coverage of the AWG. Superheterodyne up-conversion is done in two-stages where the signal is first up-converted to an intermediate frequency (IF) and after filtering out the undesired spectral components the IF spectrum is up-converted again to a higher RF frequency. Figure 12 shows such configuration where the AWG's DAC running at sample rate f_s digitally up-converts the signal to an IF band using its internal digital complex modulator and the NCO followed by an external mixer driven by a fixed frequency, f_{LO} , local oscillator that produces the final output spectrum.

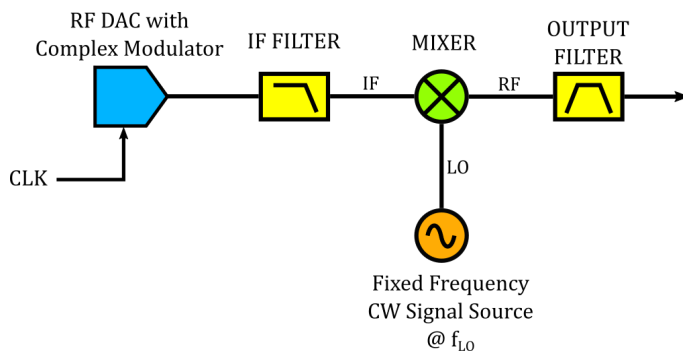

FIGURE 12. Superheterodyne up-conversion using an RF DAC with digital complex modulator and an external mixer with fixed frequency LO.

In this setup, either a low-pass or a band-pass filter is needed at the output of the AWG to remove the images of the signal spectrum before applying it to the IF port of the mixer. In the frequency domain, an up-converting mixer produces a series of mixing products at the RF port given by [9]:

$$f_{RF} = M \times f_{IF} + N \times f_{LO}$$

Where $M = 0, \pm 1, \pm 2, \pm 3, \dots$ and $N = 0, \pm 1, \pm 2, \pm 3, \dots$. The terms corresponding to $M = \pm 1$ and $N = 1$ (also referred to as the first-order mixing products) produce up-converted one-to-one spectrums of the IF signal. In this discussion, we shall only focus on the first-order mixing products and the $M = 0$ and $N = 1$ product which is the LO leakage, however, the higher order products should be taken into account if wideband rejection of those spectral components is required.

Figure 13 shows the IF spectrum of a waveform centered at the NCO frequency and its image centered at $f_s - f_{NCO}$. The output spectrum of the mixer is shown in Figure 14. The upper and lower sidebands are the two first-order mixing products and depending on the choice of the LO frequency either one could be selected as the final output signal using the appropriate band-pass filter. It should be noted that the lower sideband undergoes spectrum inversion. The center frequency of the output signal can be adjusted down to sub-Hz resolution without changing the LO frequency by tuning the NCO frequency.

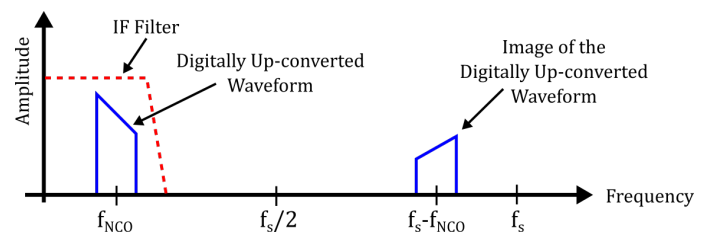

FIGURE 13. Superheterodyne up-conversion: IF generation using AWG's NCO.

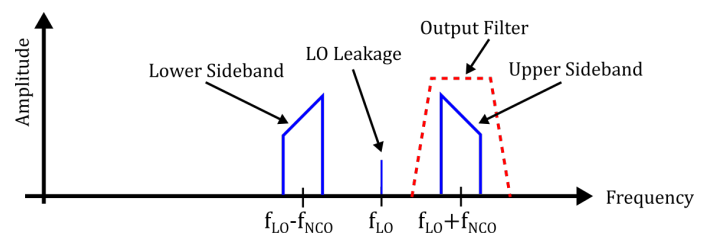

FIGURE 14. Superheterodyne up-conversion: 2nd up-conversion using an external mixer.

The bandwidth of the up-converted signal plays an important role in the choice of the LO and NCO frequencies. These frequencies should be planned such that there is enough separation between the band edges of the spectrum of the up-converted signal given by $(f_{LO} \pm f_{NCO}) \mp \frac{BW_{signal}}{2}$ and the LO frequency in order for practical filters to be used to adequately attenuate the LO leakage.

Having a fixed LO offers a significantly lower cost to complex microwave signal generation compared to the traditional VSG's that use IQ modulators and analog synthesizers as the LO. Additionally, only one channel of an AWG is needed to generate both the I and Q baseband signals whereas a VSG requires two channels of an AWG: one for the I waveform and another one for the Q waveforms. Also in contrast to VSG, the LO leakage is out of band from the main signal spectrum and can be filtered out. This becomes extremely advantageous when very high on-to-off ratio is desired for pulsed signals. Furthermore, since the modulation is done in the digital domain, the quadrature relationship between the I and Q waveforms over the entire signal bandwidth is perfectly preserved. Therefore, no calibration for correcting the I-Q

imbalance is needed. The distortion due to the frequency response of the analog path can be compensated by applying pre-compensating FIR filters to the I and Q waveforms in the digital domain [7].

This scheme can efficiently be extended to larger number of AWG channels by sharing the LO source. Figure 15 shows this up-conversion technique for a 4-channel AWG where a single LO source is split 4 ways using a power divider that drives the mixers.

Depending on the LO power requirement of the mixers, a high-power gain stage might be needed followed by an optional LO band-pass filter to attenuate the wideband noise into the LO port of the mixers. The LO source and the clock system of the AWG are locked together through their phase-locked loop (PLL) references for accurate frequency locking of the output carrier frequency and the modulating baseband signals. A final gain stage might also be required to amplify the output signal and to compensate for the power loss due to the mixer conversion gain and filters' insertion loss.

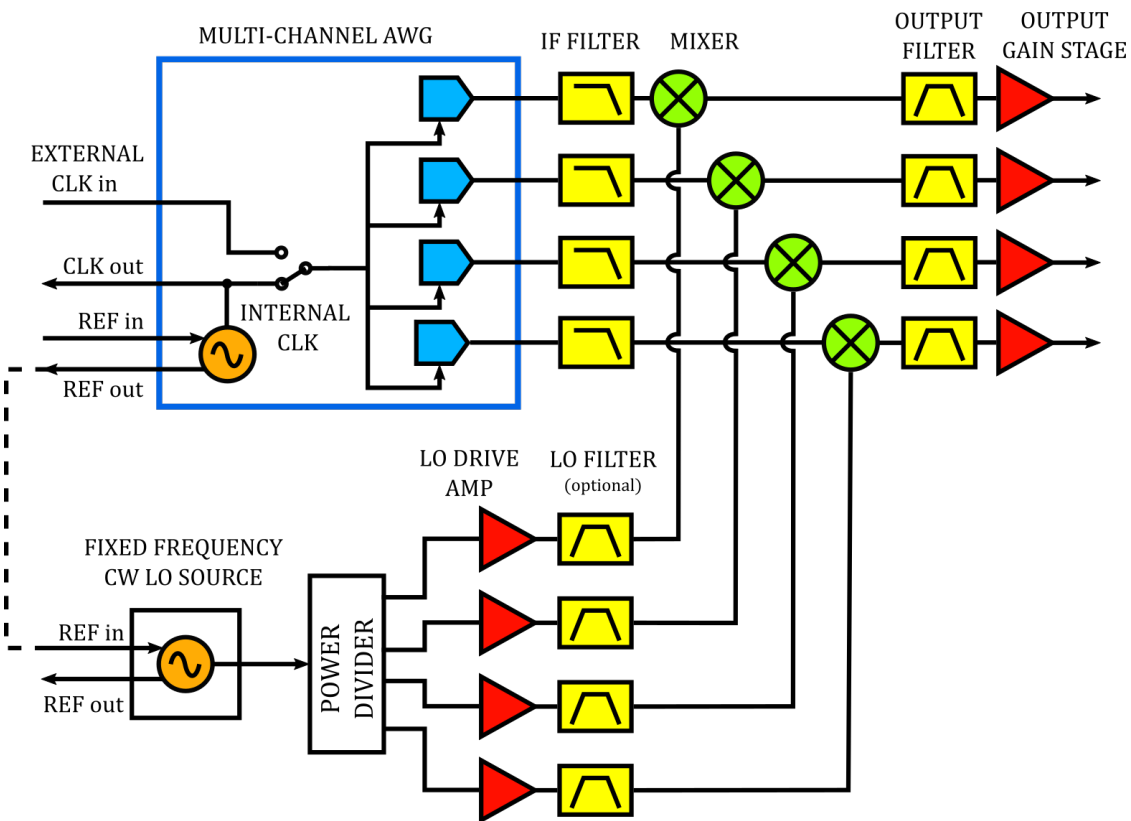

FIGURE 15. Multi-channel superheterodyne up-conversion with shared LO source.

Conclusion

By considering the properties of the desired signal to be generated (such as carrier frequency, bandwidth, and the required dynamic range) and the AWG's performance (such as the output dynamic range and frequency response), direct RF signal generation in the 1st or higher order Nyquist bands is possible using RF DAC's with complex modulator. This requires a suitable choice of sample rate and external filtering. For frequencies beyond the AWG's coverage or if very higher dynamic range is required, superheterodyne up-conversion using an external mixer and a fixed frequency LO is a cost effective approach for synchronized multi-channel applications.

Unlike in VSG's, signals generated by AWG's do not exhibit I-Q imbalance or carrier (NCO) leakage because the modulation and the carrier signals are created in the digital domain. This simplifies the calibration to the measurement and correction of the amplitude and phase distortion due to the composite frequency response of the DAC and the output analog path. This correction can be done by applying a digital pre-compensation filter to the baseband signals.

Bibliography

- [1] Y. Li, *In-Phase and Quadrature Imbalance: Modeling, Estimation, and Compensation*, New York, NY: Springer, 2013.
- [2] Tektronix, "Baseband Response Characterization of I-Q Modulators," 2014. [\[Online\]](#). [Accessed December 2016].
- [3] A. Chenakin, "Microwave Synthesizers," in *Modern RF and Microwave Measurement Techniques*, Cambridge University Press, 2013, pp. 61-62.
- [4] W. A. Kester, "Oversampling Interpolating DACs," in *Data Conversion Handbook*, Burlington, MA: Elsevier / Analog Devices, 2005, p. 163.
- [5] O. Vankka, "Direct Digital Synthesizers," in *Digital Synthesizers and Transmitters for Software Radio*, Dordrecht, Springer, 2005, pp. 61-63.
- [6] P. Symons, "DAC dynamic specification considerations," in *Digital Waveform Generation*, New York, NY: Cambridge University Press, 2014, pp. 318-322.
- [7] Tektronix, "AWG70000 Series Precompensation Whitepaper," 2016. [\[Online\]](#). [Accessed December 2016].
- [8] Q. Gu, "Comparison of Architectures," in *RF System Design of Transceivers for Wireless Communications*, New York, NY: Springer, 2005, pp. 350-351.
- [9] "Frequency Conversion," in *Practical RF System Design*, New York, NY: Wiley-IEEE Press, 2003, pp. 168-170.

If you have any questions please contact:

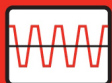

S J ELECTRONICS
POWER • TEST & MEASUREMENT



0800 583 4455



sales@sjelectronics.co.uk

[VISIT WEBSITE](#)

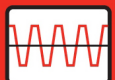

Contact Information:

- Australia*** 1 800 709 465
- Austria** 00800 2255 4835
- Balkans, Israel, South Africa and other ISE Countries** +41 52 675 3777
- Belgium*** 00800 2255 4835
- Brazil** +55 (11) 3759 7627
- Canada** 1 800 833 9200
- Central East Europe / Baltics** +41 52 675 3777
- Central Europe / Greece** +41 52 675 3777
- Denmark** +45 80 88 1401
- Finland** +41 52 675 3777
- France*** 00800 2255 4835
- Germany*** 00800 2255 4835
- Hong Kong** 400 820 5835
- India** 000 800 650 1835
- Indonesia** 007 803 601 5249
- Italy** 00800 2255 4835
- Japan** 81 (3) 6714 3010
- Luxembourg** +41 52 675 3777
- Malaysia** 1 800 22 55835
- Mexico, Central/South America and Caribbean** 52 (55) 56 04 50 90
- Middle East, Asia, and North Africa** +41 52 675 3777
- The Netherlands*** 00800 2255 4835
- New Zealand** 0800 800 238
- Norway** 800 16098
- People's Republic of China** 400 820 5835
- Philippines** 1 800 1601 0077
- Poland** +41 52 675 3777
- Portugal** 80 08 12370
- Republic of Korea** +82 2 6917 5000
- Russia / CIS** +7 (495) 6647564
- Singapore** 800 6011 473
- South Africa** +41 52 675 3777
- Spain*** 00800 2255 4835
- Sweden*** 00800 2255 4835
- Switzerland*** 00800 2255 4835
- Taiwan** 886 (2) 2656 6688
- Thailand** 1 800 011 931
- United Kingdom / Ireland*** 00800 2255 4835
- USA** 1 800 833 9200
- Vietnam** 12060128

* European toll-free number. If not accessible, call: +41 52 675 3777



S J ELECTRONICS
POWER • TEST & MEASUREMENT

☎ 0800 583 4455

✉ sales@sjelectronics.co.uk



Find more valuable resources at TEK.COM

Copyright © Tektronix. All rights reserved. Tektronix products are covered by U.S. and foreign patents, issued and pending. Information in this publication supersedes that in all previously published material. Specification and price change privileges reserved. TEKTRONIX and TEK are registered trademarks of Tektronix, Inc. All other trade names referenced are the service marks, trademarks or registered trademarks of their respective companies.

01/17 EA 76W-60983-0

