

# Instruction Manual

**Tektronix**

**P6330**  
**3.5 GHz Differential Probe**  
**071-0757-04**



**S J ELECTRONICS**  
POWER • TEST & MEASUREMENT



0800 583 4455



sales@sjelectronics.co.uk

VISIT   
WEBSITE

## **Warning**

The servicing instructions are for use by qualified personnel only. To avoid personal injury, do not perform any servicing unless you are qualified to do so. Refer to all safety summaries prior to performing service.

**www.tektronix.com**

Copyright © Tektronix, Inc. All rights reserved.

Tektronix products are covered by U.S. and foreign patents, issued and pending. Information in this publication supercedes that in all previously published material. Specifications and price change privileges reserved.

Tektronix, Inc., P.O. Box 500, Beaverton, OR 97077

TEKTRONIX, TEK, TEKPROBE, and SureFoot are registered trademarks of Tektronix, Inc. KlipChip is a trademark of Tektronix, Inc.

## WARRANTY

Tektronix warrants that the products that it manufactures and sells will be free from defects in materials and workmanship for a period of one (1) year from the date of shipment. If a product proves defective during this warranty period, Tektronix, at its option, either will repair the defective product without charge for parts and labor, or will provide a replacement in exchange for the defective product.

In order to obtain service under this warranty, Customer must notify Tektronix of the defect before the expiration of the warranty period and make suitable arrangements for the performance of service. Customer shall be responsible for packaging and shipping the defective product to the service center designated by Tektronix, with shipping charges prepaid. Tektronix shall pay for the return of the product to Customer if the shipment is to a location within the country in which the Tektronix service center is located. Customer shall be responsible for paying all shipping charges, duties, taxes, and any other charges for products returned to any other locations.

This warranty shall not apply to any defect, failure or damage caused by improper use or improper or inadequate maintenance and care. Tektronix shall not be obligated to furnish service under this warranty a) to repair damage resulting from attempts by personnel other than Tektronix representatives to install, repair or service the product; b) to repair damage resulting from improper use or connection to incompatible equipment; c) to repair any damage or malfunction caused by the use of non-Tektronix supplies; or d) to service a product that has been modified or integrated with other products when the effect of such modification or integration increases the time or difficulty of servicing the product.

**THIS WARRANTY IS GIVEN BY TEKTRONIX IN LIEU OF ANY OTHER WARRANTIES, EXPRESS OR IMPLIED. TEKTRONIX AND ITS VENDORS DISCLAIM ANY IMPLIED WARRANTIES OF MERCHANTABILITY OR FITNESS FOR A PARTICULAR PURPOSE. TEKTRONIX' RESPONSIBILITY TO REPAIR OR REPLACE DEFECTIVE PRODUCTS IS THE SOLE AND EXCLUSIVE REMEDY PROVIDED TO THE CUSTOMER FOR BREACH OF THIS WARRANTY. TEKTRONIX AND ITS VENDORS WILL NOT BE LIABLE FOR ANY INDIRECT, SPECIAL, INCIDENTAL, OR CONSEQUENTIAL DAMAGES IRRESPECTIVE OF WHETHER TEKTRONIX OR THE VENDOR HAS ADVANCE NOTICE OF THE POSSIBILITY OF SUCH DAMAGES.**



# Table of Contents

General Safety Summary .....	v
Service Safety Summary .....	vii
Contacting Tektronix .....	viii
<b>Product Features and Accessories .....</b>	<b>1</b>
Options .....	2
Features and Standard Accessories .....	3
Optional Accessories .....	7
<b>Operating Basics .....</b>	<b>9</b>
Installation .....	9
Instruments with the TEKPROBE Interface (Tektronix TDS 400, 500, 600, and 700 Series Oscilloscopes) .....	10
Instruments without the TEKPROBE Interface .....	10
Input Voltage Limits .....	10
Maximum Input Voltage .....	11
Common-Mode Signal Range .....	11
Differential-Mode Signal Range .....	11
Common-Mode Rejection .....	11
Probing Techniques to Maximize CMRR .....	12
Electrical Effects of Accessories .....	13
Input Impedance and Probe Loading .....	14
Probe Grounding .....	15
<b>Functional Check .....</b>	<b>17</b>
<b>Reference .....</b>	<b>19</b>
Problems with Single-Ended Measurements .....	19
Differential Measurements .....	19
Common-Mode Rejection Ratio .....	20
Assessing CMRR Error .....	20
Input Impedance Effects on CMRR .....	21
Extending the Input Leads .....	21
Extending the Ground Lead .....	22
Extending the Probe Output .....	22
Terminating the Probe .....	22
Effect of Extending the Output Cable .....	23
Using the Probe with Other Instruments .....	23

<b>Specifications</b> .....	<b>25</b>
Warranted Characteristics .....	25
Typical Characteristics .....	26
Nominal Characteristics .....	30
<b>Theory of Operation</b> .....	<b>33</b>
Probe Head and Cable Assembly .....	34
Compensation Box .....	34
Offset Amplifier .....	34
Probe Identification EEPROM .....	34
TEKPROBE Interface .....	35
<b>Performance Verification</b> .....	<b>37</b>
Equipment Required .....	37
Equipment Setup .....	38
Probe Calibration Fixture .....	39
Using the Probe Calibration Fixture .....	39
Output Offset Voltage .....	41
DC Gain Accuracy .....	41
Rise Time .....	43
<b>Adjustments</b> .....	<b>47</b>
Equipment Required .....	47
Removing the Compensation Box Cover .....	48
Offset Zero and DC CMRR .....	50
Offset Range .....	53
Replacing the Compensation Box Cover .....	54
<b>Maintenance</b> .....	<b>55</b>
Replacing TEKPROBE Interface Pins .....	55
Removing and Replacing the TEKPROBE Interface Collar ..	56
Inspection and Cleaning .....	57
Replacement Parts .....	57
Preparation for Shipment .....	57
<b>Replaceable Parts</b> .....	<b>59</b>
Parts Ordering Information .....	59
Using the Replaceable Parts List .....	60
Item Names .....	60
Indentation System .....	60
Abbreviations .....	60

## List of Figures

Figure 1: P6330 differential probe .....	1
Figure 2: Input connector of TEKPROBE interface .....	10
Figure 3: Using the variable spacing adapter .....	12
Figure 4: Using the TwinFoot adapter .....	12
Figure 5: Typical effects on a signal using probe tip adapters .	13
Figure 6: Typical probe input model .....	14
Figure 7: Probe ground input .....	15
Figure 8: Probe functional check connections .....	17
Figure 9: Simplified model of a differential amplifier .....	20
Figure 10: Twisting the input leads .....	22
Figure 11: Typical common-mode gain .....	28
Figure 12: Typical differential input impedance vs frequency .	28
Figure 13: Probe head and compensation box dimensions ....	29
Figure 14: Simplified schematic diagram .....	33
Figure 15: TEKPROBE interface .....	35
Figure 16: Probe Calibration Fixture .....	39
Figure 17: Probe Calibration Fixture test points .....	40
Figure 18: Setup for the output offset voltage test .....	41
Figure 19: DC Gain Accuracy setup .....	42
Figure 20: Test system rise time setup .....	43
Figure 21: Test system rise time setup with probe .....	44
Figure 22: Verifying both probe pins are contacting the DM test points .....	45
Figure 23: Removing the compensation box cover .....	48
Figure 24: Adjustment and test point locations .....	49
Figure 25: Offset zero and DC CMRR setup .....	51
Figure 26: P6330 offset range setup .....	53
Figure 27: Replacing the compensation box cover .....	54
Figure 28: Replacing TEKPROBE interface pins .....	55
Figure 29: Replacing the TEKPROBE interface collar .....	56
Figure 30: P6330 replaceable parts .....	61
Figure 31: P6330 standard accessories .....	63
Figure 32: P6330 optional accessories .....	65

## Table of Contents

---





# General Safety Summary

Review the following safety precautions to avoid injury and prevent damage to this product or any products connected to it. To avoid potential hazards, use this product only as specified.

## To Avoid Fire or Personal Injury

**Connect and Disconnect Properly.** Connect the probe output to the measurement instrument before connecting the probe to the circuit under test. Disconnect the probe input and the probe ground from the circuit under test before disconnecting the probe from the measurement instrument.

**Observe All Terminal Ratings.** To avoid fire or shock hazard, observe all ratings and markings on the product. Consult the product manual for further ratings information before making connections to the product.

The common terminal is at ground potential. Do not connect the common terminal to elevated voltages.

**Do Not Operate Without Covers.** Do not operate this product with covers or panels removed.

**Do Not Operate With Suspected Failures.** If you suspect there is damage to this product, have it inspected by qualified service personnel.

**Do Not Operate in Wet/Damp Conditions.**

**Do Not Operate in an Explosive Atmosphere.**

**Keep Product Surfaces Clean and Dry.**

## Safety Terms and Symbols

**Terms in This Manual.** These terms may appear in this manual:



---

**WARNING.** *Warning statements identify conditions or practices that could result in injury or loss of life.*

---



---

**CAUTION.** *Caution statements identify conditions or practices that could result in damage to this product or other property.*

---

**Terms on the Product.** These terms may appear on the product:

DANGER indicates an injury hazard immediately accessible as you read the marking.

WARNING indicates an injury hazard not immediately accessible as you read the marking.

CAUTION indicates a hazard to property including the product.

**Symbols on the Product.** These symbols may appear on the product:



CAUTION  
Refer to Manual



## Service Safety Summary

Only qualified personnel should perform service procedures. Read this *Service Safety Summary* and the *General Safety Summary* before performing any service procedures.

**Do Not Service Alone.** Do not perform internal service or adjustments of this product unless another person capable of rendering first aid and resuscitation is present.

## Contacting Tektronix

**Phone** 1-800-833-9200\*

---

**Address** Tektronix, Inc.  
Department or name (if known)  
14200 SW Karl Braun Drive  
P.O. Box 500  
Beaverton, OR 97077  
USA

---

**Web site** [www.tektronix.com](http://www.tektronix.com)

---

**Sales support** 1-800-833-9200, select option 1\*

---

**Service support** 1-800-833-9200, select option 2\*

---

**Technical support** Email: [techsupport@tektronix.com](mailto:techsupport@tektronix.com)  
1-800-833-9200, select option 3\*  
6:00 a.m. - 5:00 p.m. Pacific time

---

\* **This phone number is toll free in North America. After office hours, please leave a voice mail message. Outside North America, contact a Tektronix sales office or distributor; see the Tektronix web site for a list of offices.**

---

## Product Features and Accessories

The P6330 is a high-bandwidth (3.5 GHz) active differential probe with a miniaturized probe head design. The probe has low circuit loading, high common-mode rejection, and comes with a variety of accessories for connecting to surface-mount devices and other components.

The P6330 probe uses the TEKPROBE interface, which provides power, selects the correct display scaling, and automatically sets the 50  $\Omega$  termination on the oscilloscope input. The TEKPROBE interface is standard on many Tektronix TDS series oscilloscopes. The Tektronix 1103 TEKPROBE Power Supply can be used for instruments without the TEKPROBE interface (refer to page 7).

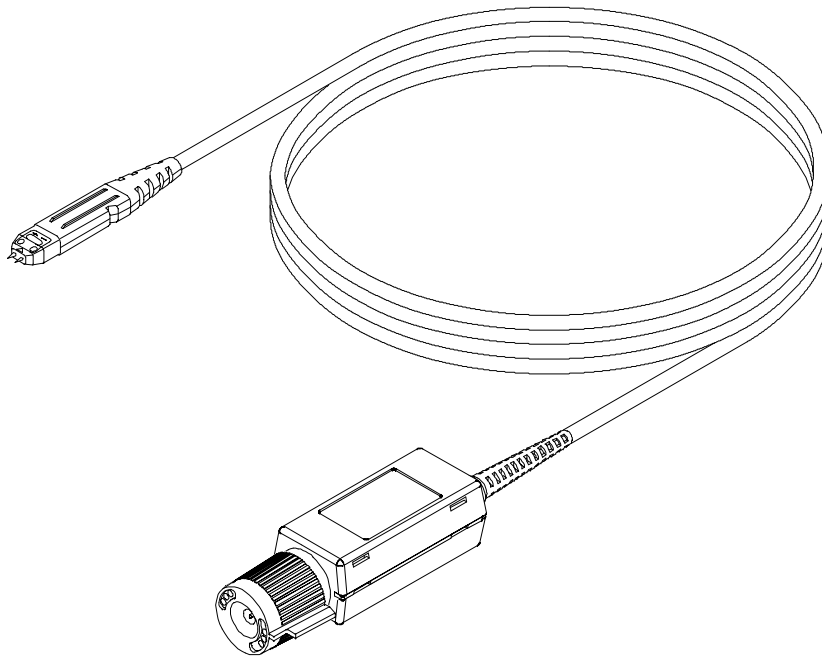

**Figure 1: P6330 differential probe**

## Options

The following options are available when ordering the P6330 probe:

- Option D1 - Calibration Data
- Option C3 - 3 years Calibration Service
- Option D3 - 3 years Calibration Data (requires Option C3)
- Option R3 - 3 years Extended Warranty

## Features and Standard Accessories

Table 1 shows the features and standard accessories of the P6330 differential probe.

**Table 1: P6330 features and standard accessories**

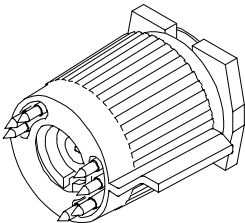
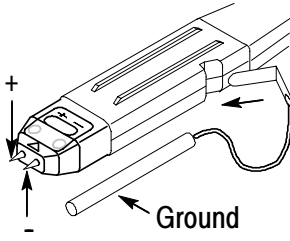
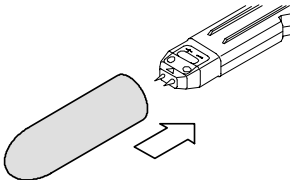
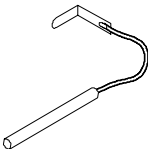
Feature/Accessory	Description
	<p><b>TEKPROBE interface.</b> The TEKPROBE interface supplies power to the probe, selects the correct display scaling, and automatically sets the 50 <math>\Omega</math> termination on the oscilloscope input.</p> <p>If your oscilloscope does not have the TEKPROBE interface, you can use the optional 1103 power supply (refer to page 7).</p>
	<p><b>Input connections.</b> The plus and minus connections of the probe head accept the standard and optional probe accessories (some of which connect through the square pin adapter).</p> <p><b>WARNING:</b> Skin penetration hazard. To prevent injury, install the probe tip cover when the probe is not in use. The probe tips are extremely sharp to ensure good contact and measurement integrity.</p>
	<p><b>Probe tip cover.</b> The probe tips are extremely sharp to ensure good contact and measurement integrity. When not using the probe, slide the probe tip cover over the probe head to prevent damage to the probe tips and to protect yourself from personal injury.</p> <p>Tektronix part number: 200-4236-00</p>
	<p><b>Three-inch ground lead (2 ea).</b> Use the ground lead for connecting the probe ground to the circuit, if needed. The socketed end of the lead may be connected to accessories, or fitted onto 0.025-inch pins.</p> <p>Tektronix part number: 196-3469-00 (package of 2)</p>

**Table 1: P6330 features and standard accessories (Cont.)**

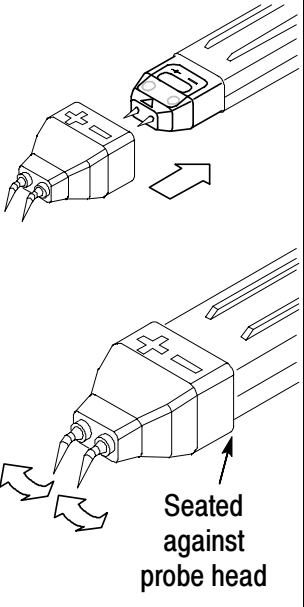
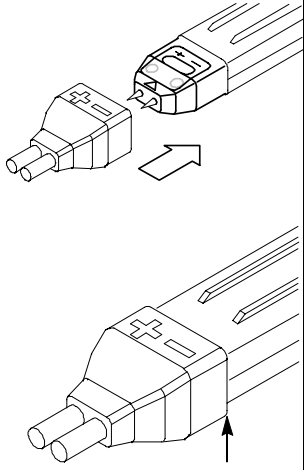

Feature/Accessory	Description
 <p style="text-align: center;">Seated against probe head</p>	<p><b>Variable spacing adapter (4 ea).</b> The variable spacing adapter fits over the probe tip. Push the adapter onto the probe tip until it seats against the probe head.</p> <p>Use the variable spacing adapter to probe any two adjacent leads or test points spaced between 0.020 and 0.180-inches apart. Adjust the articulated pins by gently rotating them using a pair of tweezers.</p> <p><b>NOTE:</b> The articulated pins can be bent, but they are fragile. Use extreme care when bending the pins.</p> <p>The elastomeric contacts inside the adapter are rated for 50 - 75 insertion cycles with the probe tip. Replace the adapter after exceeding these limits to avoid unreliable operation.</p> <p>Tektronix part number: 016-1885-00 (package of 4)</p>
 <p style="text-align: center;">Seated against probe head</p>	<p><b>Square pin adapter (4 ea).</b> Push the square pin adapter onto the probe tip until it seats against the probe head. Use the square pin adapter to connect the probe to other accessories, such as the Y-lead adapter or TwinFoot adapter. The inputs on the adapter are spaced 0.100-inches apart.</p> <p><b>CAUTION:</b> To avoid damaging the square pin connectors, do not insert anything larger than a 0.025-inch square pin into the inputs.</p> <p>The elastomeric contacts inside the adapter are rated for 50 - 75 insertion cycles with the probe tip. Replace the adapter after exceeding these limits to avoid unreliable operation.</p> <p>Tektronix part number: 016-1884-00 (package of 4)</p>

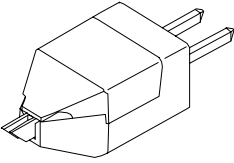
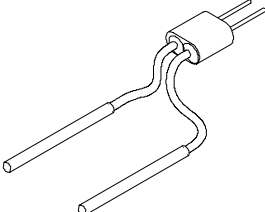
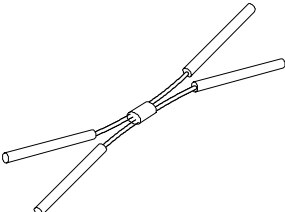
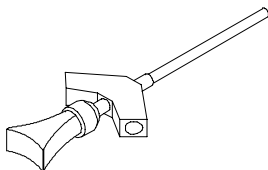
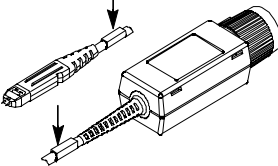

**Table 1: P6330 features and standard accessories (Cont.)**

Feature/Accessory	Description
	<p><b>TwinFoot adapter (4 ea).</b> Use the TwinFoot adapter to probe two adjacent leads on a surface-mount integrated circuit. The TwinFoot adapter connects to the probe through the square pin adapter. Flexible fingers adapt to a range of lead spacings. See Figure 4 on page 12.</p> <p>Tektronix part number: 016-1785-00 (package of 4)</p>
	<p><b>Y-lead adapter (2 ea).</b> The Y-lead adapter connects to the probe through the square pin adapter. The socketed ends of the leads may be connected to the probe tips and accessories, or fitted onto 0.025-inch pins.</p> <p>Tektronix part number: 196-3468-00 (package of 2)</p>
	<p><b>X-lead adapter (2 ea).</b> The X-lead adapter connects between accessories fitted with 0.025-inch pins, such as the SMT KlipChip and Micro KlipChip adapters.</p> <p>You can use the X-lead adapter with the adapters below to make connections between the probe tip and your circuit under test. Be aware of the electrical effects of the added lead length of the adapters, especially as circuit frequencies increase.</p> <p>Tektronix part number: 196-3473-XX (package of 1)</p>
	<p><b>SMT KlipChip adapter (2 ea).</b> Use this accessory to probe the leads on dual-in-line packages (DIP). The 0.025-inch pins recessed in the adapter body may be connected to the X- and Y-lead adapters, and the 3-inch ground leads.</p> <p>Tektronix part number: 206-0364-XX (package of 1)</p>
<p>Color marker bands</p> 	<p><b>Color marker bands (10 ea).</b> Attach matching pairs of the color marker bands onto the cable at the head and compensation box of each probe. The marker bands enable quick verification of which probe is connected to which instrument channel.</p> <p>Tektronix part number: 016-1315-00 (package of 10)</p>

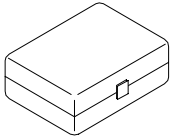
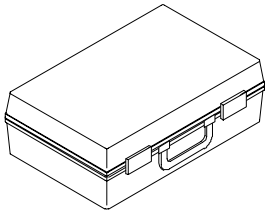
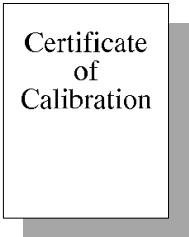
**Table 1: P6330 features and standard accessories (Cont.)**

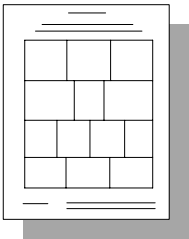
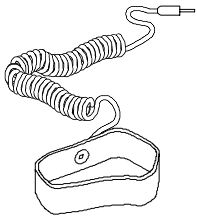
Feature/Accessory	Description
	<p><b>Plastic accessory box.</b> Use the plastic box to store the probe accessories when not in use.</p> <p>Tektronix part number: 006-7164-00</p>
	<p><b>Instrument case.</b> The instrument case protects the probe from harsh environments and provides room for storing optional accessories.</p> <p>Tektronix part number: 016-1879-XX</p>
	<p><b>Calibration certificate.</b> A certificate of traceable calibration is provided with every instrument shipped.</p>
	<p><b>Instruction Manual.</b> Provides instructions for operating the P6330 differential probe and procedures for verifying the performance, adjusting, and maintaining the probe.</p> <p>Tektronix part number: 071-0757-XX</p>
	<p><b>Accessory reorder sheet.</b> The accessory reorder sheet provides photos and part numbers for identifying standard and optional accessories that are compatible with your probe.</p> <p>Tektronix part number 001-1362-XX</p>
	<p><b>Antistatic wrist strap.</b> When using the probe, always work at an antistatic work station and wear the antistatic wrist strap.</p> <p>Tektronix part number: 006-3415-04</p>

## Optional Accessories

Table 2 shows the optional accessories that you can order for the P6330 differential probe.

**Table 2: Optional accessories**

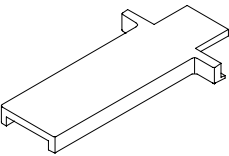
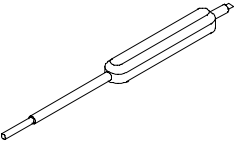
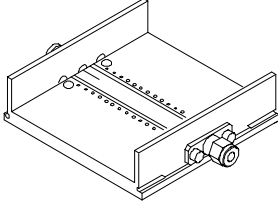
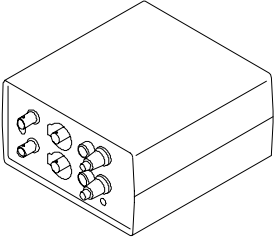
Accessory	Description
	<p><b>Release tool.</b> Use for opening the compensation box to access adjustments.</p> <p>Order Tektronix part number 003-1383-00</p>
	<p><b>Adjustment tool.</b> Use for making internal adjustments to the probe.</p> <p>Order Tektronix part number 003-0675-01</p>
	<p><b>Probe calibration fixture.</b> Use the probe calibration fixture to perform some of the calibration procedures. The calibration fixture connects to signal sources used to test the probe characteristics. Refer to page 39 for details on using the fixture.</p> <p>Order Tektronix part number 067-0419-XX</p>
	<p><b>1103 Power supply.</b> Order the 1103 power supply for performance verification procedures, and for instruments that do not have the TEKPROBE Interface. Power cord options are available for the following countries or regions.</p> <p><b>Standard.</b> North America and Japan</p> <p><b>Option A1.</b> European</p> <p><b>Option A2.</b> UK</p> <p><b>Option A3.</b> Australia</p> <p><b>Option A5.</b> Switzerland</p>

**Table 2: Optional accessories (Cont.)**

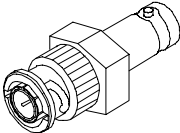
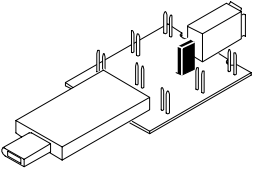
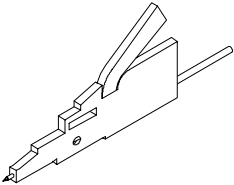
Accessory	Description
	<p><b>50 <math>\Omega</math> termination.</b> Terminates the output of the 1103 power supply to the required 50 <math>\Omega</math> if the oscilloscope does not have a 50 <math>\Omega</math> input setting. Order Tektronix part number 011-0049-01.</p> <p><b>50 <math>\Omega</math> BNC cable.</b> Connects to the 1103 output. Order Tektronix part number: 012-0076-00</p>
	<p><b>IEEE1394 Adapter.</b> The IEEE1394 Adapter allows you to probe signals on the bus, external to system enclosures, without disturbing system operation. The adapter maintains a balanced 55 <math>\Omega</math> signal path and can be used in both single-ended and differential modes.</p> <p>Order Tektronix part number: 679-5027-00</p>
	<p><b>Micro KlipChip adapters (2 ea).</b> Use the adapters to probe the leads on integrated circuits that are surface-mounted. The 0.025-inch pin at the back of the adapter may be connected to the X- and Y-lead adapters, and the 3-inch ground leads.</p> <p>Order Tektronix part number: SMK4 (package of 4)</p>

# Operating Basics

This section discusses operating considerations and probing techniques. For more detailed information about differential measurements and common-mode rejection ratio (CMRR), see the *Reference* section on page 19.

The P6330 probe design is optimized for high bandwidth, low capacitance applications; it is not a general purpose probe. The probe head and tips are miniaturized for electrical characteristics and access to dense circuitry, and must be handled carefully. Rough or careless use will likely damage the probe.

To avoid damaging the probe tips, minimize your lateral pressure on the tips. Always probe as directly straight onto the circuit (perpendicular) as possible. The probe tips are extremely sharp to ensure good contact and measurement integrity.



---

**WARNING.** *Skin penetration hazard. Use care when handling the probe. To prevent injury and/or probe damage, install the protective cover over the probe tips when the probe is not in use.*

---

## Installation

Before you connect the output of the P6330 differential probe, determine whether or not your oscilloscope has a TEKPROBE interface. See Figure 2 on page 10.

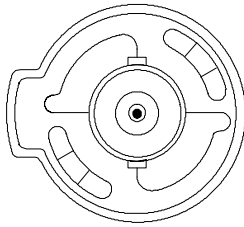

**Figure 2: Input connector of TEKPROBE interface**

**Instruments with the TEKPROBE Interface (Tektronix TDS 400, 500, 600, and 700 Series Oscilloscopes)**

On instruments that have the TEKPROBE interface, simply connect the probe to the input. The TEKPROBE interface provides power, selects the correct display scaling, and automatically sets the 50  $\Omega$  termination on the oscilloscope input.

---

**NOTE.** *TDS 400 and TDS 400A series oscilloscopes do not interpret the scale factor coding of the P6330 differential probe. To correct for this problem, divide the measurement (or scale factor) by 5.*

---

**Instruments without the TEKPROBE Interface**

On instruments that do not have the TEKPROBE interface, you must order the optional 1103 power supply (refer to page 7). Each 1103 can supply power for two probes. The input of the oscilloscope must also terminate into 50  $\Omega$ . Refer to page 22 for information on the effects of extending the output of the probe.

## Input Voltage Limits

The P6330 differential probe is designed to probe low-voltage circuits. Before probing a voltage, take into account the limits for maximum input voltage, the common-mode signal range, and the differential-mode signal range. For specific limits, see *Specifications* on page 25.

### Maximum Input Voltage

The maximum input voltage is the maximum voltage to ground that the inputs can withstand without damaging the input circuitry of the probe.



---

**CAUTION.** To avoid damaging the inputs of the P6330 differential probe, do not apply more than  $\pm 15$  V (DC + peak AC) between each input and ground.

---

### Common-Mode Signal Range

The common-mode signal range is the maximum voltage that you can apply to each input, with respect to earth ground, without saturating the input circuitry of the probe. A common-mode voltage that exceeds the common-mode signal range may produce an erroneous output waveform even when the differential-mode specification is met. For *Specifications*, refer to page 25.

### Differential-Mode Signal Range

The differential-mode signal range is the maximum voltage difference between the plus and minus inputs that the probe can accept without distorting the signal. The distortion from a voltage that is too large can result in a clipped or otherwise distorted and inaccurate measurement. For *Specifications*, refer to page 25.

## Common-Mode Rejection

The common-mode rejection ratio (CMRR) is the ability of a probe to reject signals that are common to both inputs. More precisely, CMRR is the ratio of the differential gain to the common-mode gain. The higher the ratio, the greater the ability to reject common-mode signals.

Common-mode rejection decreases as the input frequency increases. Figure 11 on page 28 is a plot of typical CMRR of the probe versus input frequency. For additional information about CMRR, see page 20.

## Probing Techniques to Maximize CMRR

The common-mode rejection of the probe is highest when the probe is applied directly to the circuit, without using adapters. However, some probing tasks are made easier using accessories included with the probe. The accessories shown in Figures 3 and 4 achieve a high CMRR by minimizing the distance between the probe head and the signal source.

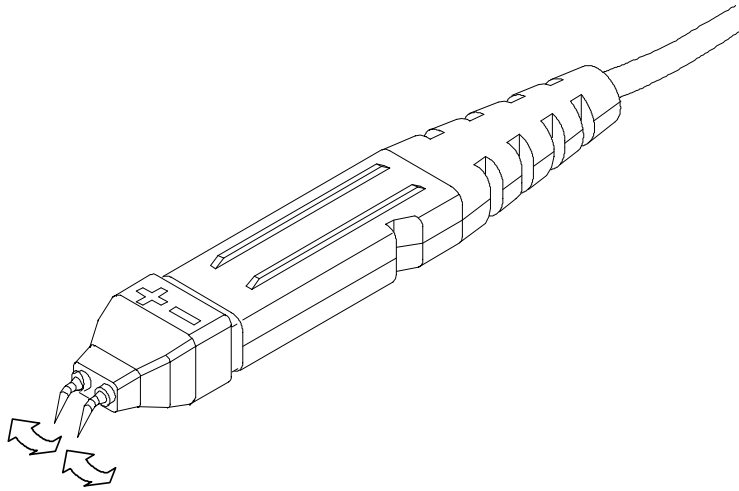

**Figure 3: Using the variable spacing adapter**

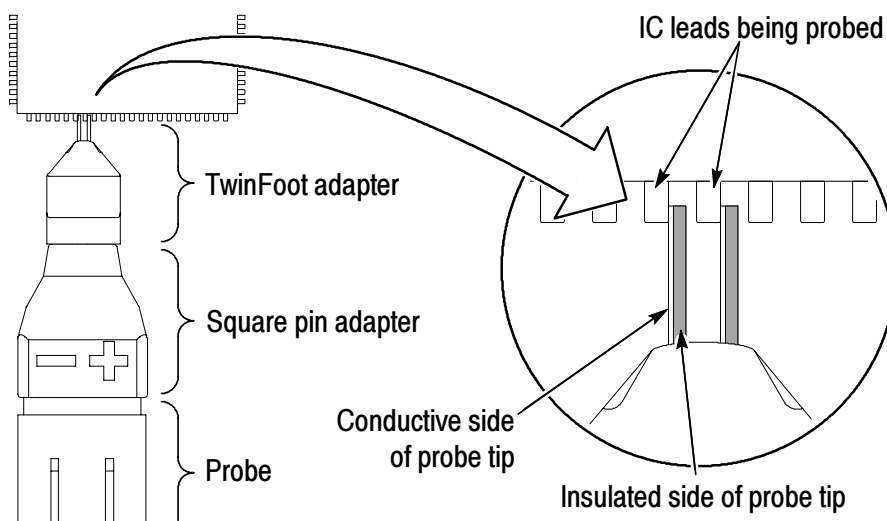

**Figure 4: Using the TwinFoot adapter**



## Electrical Effects of Accessories

The probe tip accessories included with your probe help connect to different types of components. While these accessories make connections easier, be aware that the adapter you choose may affect the signal you are measuring, depending on a variety of factors, including signal frequency, source impedance, and lead length.

Use the probe only (without adapters) to optimize step and frequency response. Using the probe tip adapters adds inductance and capacitance, which increases step response and aberrations, and leads to increased ripples in frequency response. These effects increase as the source impedance and the measured waveform risetimes decrease.

The recommended method for hands-free probing is to use the probe only (without adapters), with a probe positioner such as a Tektronix PPM203B. If you need a tip space between 0.020 and 0.180 inches apart, use the variable spacing adapter and the probe positioner. Use the square pin adapter for test points or component leads spaced farther than 0.180 inches apart.

Figure 5 illustrates the typical effects on a given signal using some of the adapters included with your probe.

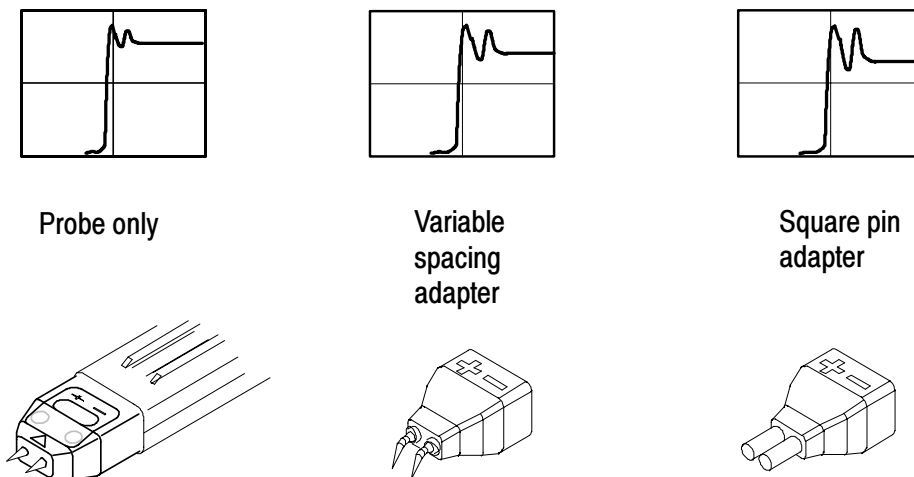
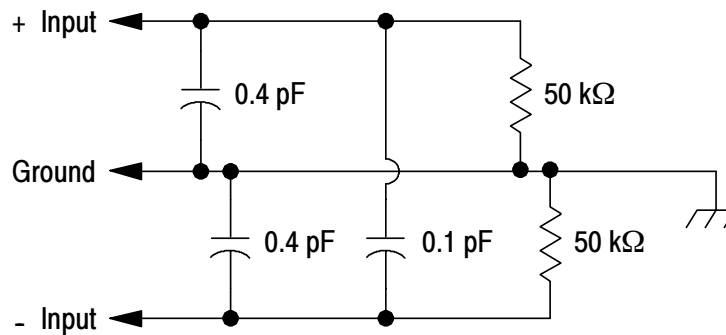

**Figure 5: Typical effects on a signal using probe tip adapters**

## Input Impedance and Probe Loading

When you connect the probe inputs to a circuit, you are introducing a new resistance, capacitance, and inductance into the circuit. Each input of the P6330 differential probe has a characteristic input impedance of  $50\text{ k}\Omega$  to ground in parallel with less than  $0.4\text{ pF}$ . See Figure 6.

For signals with low source impedance and frequency, the  $50\text{ k}\Omega$  input impedance on each input is large enough to prevent the inputs from loading the signal sources. The greater the source impedances and the higher the signal frequencies, the more you must take these factors into account.



**Figure 6: Typical probe input model**

As the impedance of the signal source on an input increases, the more the probe loads the source and reduces the signal amplitude.

The frequency of the signal also affects signal measurement. As the frequency of the signal increases, the input impedance of the probe decreases. The lower the impedance of the probe relative to that of the source, the more the probe loads the circuit under test and reduces the signal amplitude. For a graph of frequency versus input impedance, refer to Figure 12 on page 28.

## Probe Grounding

In addition to the plus and minus inputs on the probe head, there is also a ground (common) input. The ground lead slides into the notch on the side of the probe. See Figure 7.

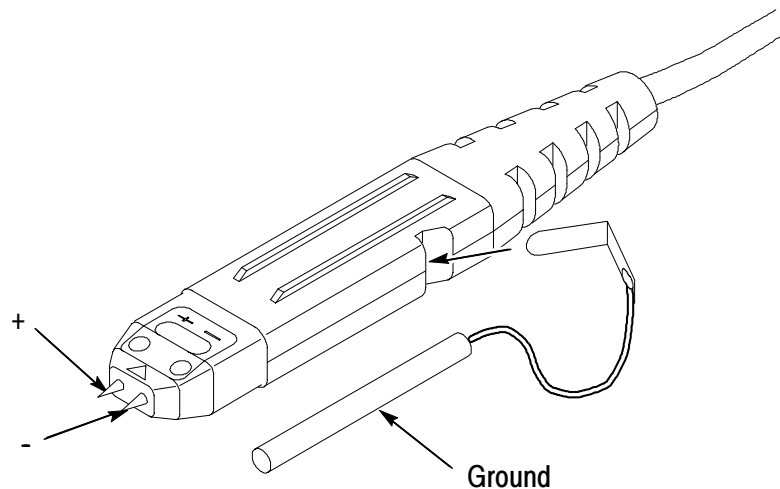

**Figure 7: Probe ground input**



**CAUTION.** To avoid damaging the circuitry under test, connect the probe ground (common), if used, to a ground-reference point only.

In most applications, the common-mode impedance to ground is greater than the differential impedance. Adding the probe ground lead does not improve the high-frequency performance of the measurement. You can use the probe to take a differential measurement regardless of whether or not the ground (common) is connected.

There are some applications that may require a ground reference connection to maintain measurement accuracy. Generally this is necessary when probing circuits which are fully isolated from ground, such as battery operated devices.



## Functional Check

After installing the probe on the oscilloscope, a functional check may be performed using the PROBE COMPENSATION connections on the front panel of the oscilloscope. See Figure 8.

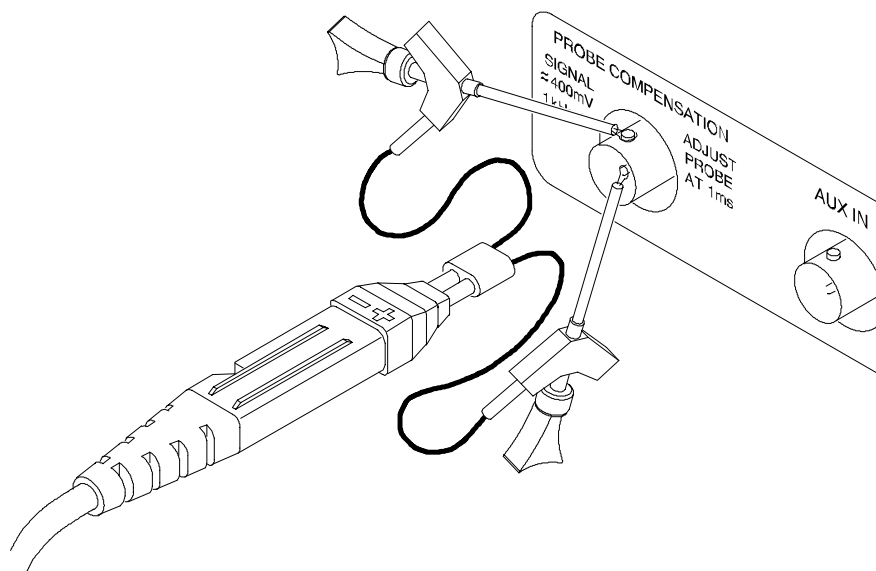

**Figure 8: Probe functional check connections**

1. Connect the probe to the oscilloscope.
2. Set the oscilloscope to display the probe channel.
3. Connect the square pin adapter to the probe tip, and connect the Y-lead adapter to the square pin adapter. Plug the SMT KlipChips into the Y-lead adapter.
4. Connect the SMT KlipChips to the PROBE COMPENSATION connections on the oscilloscope.
5. Adjust the oscilloscope to display a stable calibration waveform.

---

**NOTE.** *If your instrument supports probe calibration routines, now is a good time to perform them.*

---

6. Disconnect the probe from the PROBE COMPENSATION connector and connect the two KlipChips together.
7. With the probe offset set to 0.0 V, the oscilloscope display should be at the ground reference.
8. Set the oscilloscope volts/division to 500 mV.
9. Adjust the probe offset. The displayed waveform should vary between approximately +1.0 V and -1.0 V.

# Reference

This section contains important reference information about differential measurements and how to increase the accuracy of your measurements.

## Problems with Single-Ended Measurements

While suitable in many applications, single-ended measurements can present problems in the following situations:

- When the signal is not referenced to earth ground
- When the signal being measured is distorted or changed by connecting or disconnecting the probe ground reference lead

## Differential Measurements

Devices designed to make differential measurements avoid the problems posed by single-ended systems. These devices include a variety of differential probes, differential amplifiers, and isolators.

The differential amplifier (Figure 9) is at the heart of any device or system designed to make differential measurements. Ideally, the differential amplifier rejects any voltage that is common to the inputs and amplifies any difference between the inputs. Voltage that is common to both inputs is often referred to as the Common-Mode Voltage ( $V_{CM}$ ) and voltage that is different as the Differential-Mode Voltage ( $V_{DM}$ ).

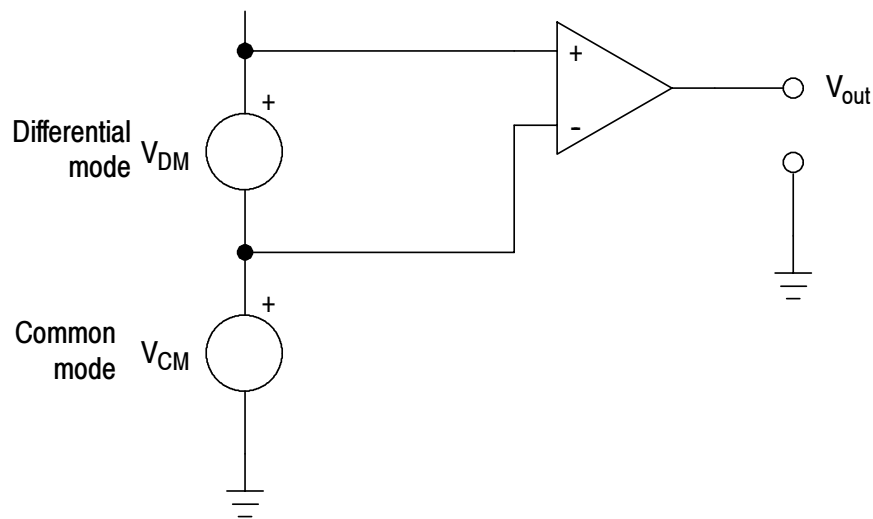

**Figure 9: Simplified model of a differential amplifier**

### Common-Mode Rejection Ratio

In reality, differential amplifiers cannot reject all of the common-mode signal. The ability of a differential amplifier to reject the common-mode signal is expressed as the Common-Mode Rejection Ratio (CMRR). The CMRR is the differential-mode gain ( $A_{DM}$ ) divided by the common-mode gain ( $A_{CM}$ ). It is expressed either as a ratio or in dB.

$$CMRR = \frac{A_{DM}}{A_{CM}} \quad dB = 20 \log \frac{A_{DM}}{A_{CM}}$$

CMRR generally is highest (best) at DC and degrades with increasing frequency.

### Assessing CMRR Error

Figure 11 on page 28 shows the CMRR of the P6330 differential probe. This derating chart assumes a common-mode signal that is sinusoidal.



A quick way to assess the magnitude of CMRR error when the common-mode signal is not sinusoidal is to connect both leads to the same point in the circuit. The oscilloscope will display only the common-mode component which is not fully rejected by the probe. While this technique may not give you entirely accurate measurements, it does allow you to determine if the magnitude of the common-mode error signal is significant.

### **Input Impedance Effects on CMRR**

The lower the input impedance of the probe relative to the source impedance, the lower the CMRR. See Figure 12 on page 28. Significant differences in the source impedance driving the two inputs will also lower the CMRR.

## **Extending the Input Leads**

At times it may be necessary to extend the probe inputs with wires or a probe tip adapter. When you do this, you should minimize the lead lengths to optimize common-mode rejection and twist the input leads together as shown in Figure 10.

Twisting the input leads together does increase capacitance that may degrade high-frequency performance. You should take into account any effects caused by the extended leads when you take a measurement.

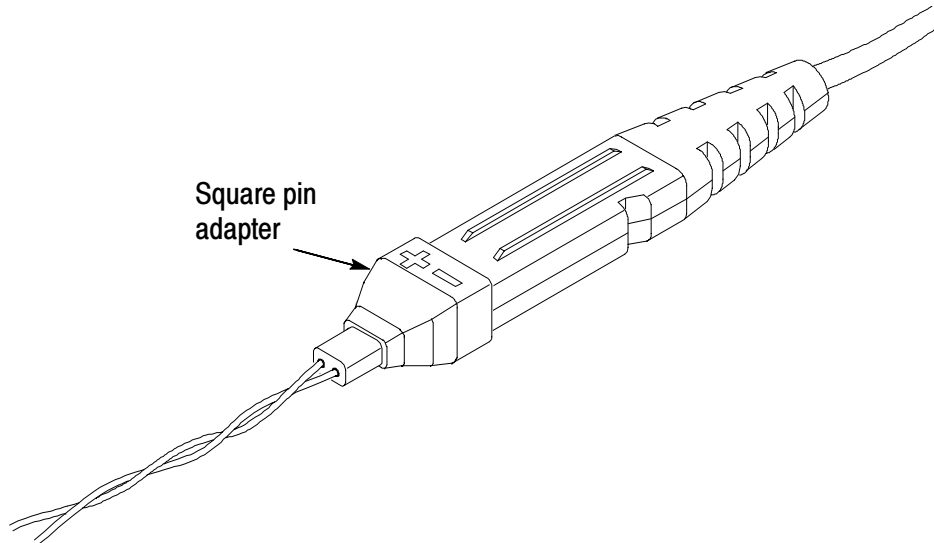

**Figure 10: Twisting the input leads**

## Extending the Ground Lead

Extending the ground lead will have little, if any, affect on your measurements. In most circuits, the ground path from the differential source has sufficiently high impedance to damp out any ringing caused by lead inductance.

## Extending the Probe Output

With the 1103 TEKPROBE power supply, it is possible to extend the output of the probe to connect the probe to other types of measurement instruments or to connect the probe to a signal source that is outside the reach of the probe.

### Terminating the Probe

The probe must terminate into 50  $\Omega$  at the input of the measurement instrument. Use the 1103 TEKPROBE power supply to adapt the differential probe and set the input impedance of the measurement instrument to 50  $\Omega$ . If the measurement instrument does not support 50  $\Omega$  input termination, connect a 50  $\Omega$  coaxial terminator on the input.

### **Effect of Extending the Output Cable**

As the frequency of a signal increases, current flow concentrates at the outer edges of the conductor, effectively increasing the impedance. This effect is known as skin loss. The P6330 probe contains circuitry to compensate for skin loss.

The compensation provides flat response with the probe cable. Extending the length of the output cable increases the amount of skin loss beyond the range of compensation correction. Minimizing the length of cable extension reduces the attenuation.

In critical applications which require high amplitude accuracy, you should first characterize the response of the probe with the extension using a leveled sinewave generator and power meter. Then, you can factor the characterization results into the measurement.

## **Using the Probe with Other Instruments**

You can use the P6330 differential probe with other types of measurement instruments, such as spectrum analyzers, time interval analyzers, and network analyzers.

When using the differential probes with these instruments, you must use the 1103 TEKPROBE power supply, and normalize the probe with the instrument before making a measurement.



# Specifications

The specifications in Tables 3 through 6 apply to a P6330 probe installed on a TDS8000 oscilloscope. When the probe is used with another oscilloscope, the oscilloscope must have an input impedance of 50  $\Omega$ . The probe must have a warm-up period of at least 20 minutes and be in an environment that does not exceed the limits described in Table 3. Specifications for the P6330 differential probe fall into three categories: warranted, typical, and nominal characteristics.

## Warranted Characteristics

Warranted characteristics (Table 3) describe guaranteed performance within tolerance limits or certain type-tested requirements.

Warranted characteristics that have checks in the *Performance Verification* section are marked with the ✓ symbol.

**Table 3: Warranted electrical characteristics**

Characteristic	Description
✓ DC gain	0.2 $\pm$ 2%
✓ Output offset voltage	$\pm$ 10 mV (+ 20° C to + 30° C, + 68° F to + 86° F) $\pm$ 50 mV displayed on screen with TEKPROBE interface
✓ Rise time (probe only)	140 ps (130 ps typical)
Maximum nondestructive input voltage	$\pm$ 15 V(DC + peak AC) between signal and common of the same channel.
Delay variation (probe-to-probe)	600 ps maximum
Temperature	Operating: 0 to + 40° C (+ 32 to + 104° F) Nonoperating: - 55 to + 75° C (-131 to + 167° F) <sup>1</sup>

**Table 3: Warranted electrical characteristics (Cont.)**

Characteristic	Description
Humidity	Operating: 0-90% RH, tested at + 30 to + 40° C (+ 68 to + 104° F)  Nonoperating: 0-90% RH, tested at + 30 to + 60° C (+ 68 to + 140° F)

<sup>1</sup> See warning that follows.



**WARNING.** To avoid a burn hazard at high ambient temperatures, do not touch the probe with bare hands at nonoperating temperatures above + 70° C. Allow sufficient time for the probe to cool before handling.

## Typical Characteristics

Typical characteristics (Tables 4 and 5) describe typical but not guaranteed performance.

**Table 4: Typical electrical characteristics**

Characteristic	Description
Bandwidth (probe only)	DC to $\geq 3.5$ GHz (- 3dB)
Differential signal range	$\pm 2.0$ V
Differential offset range	$\pm 1$ V
Linearity	$\pm 1\%$ or less of dynamic range
Common-mode signal range	+ 5 V to -4 V
Common-mode rejection ratio	$\geq 60$ dB at DC $\geq 55$ dB at 1 MHz $\geq 45$ dB at 30 MHz $\geq 25$ dB at 1 GHz

**Table 4: Typical electrical characteristics (Cont.)**

<b>Characteristic</b>	<b>Description</b>
Delay time	5.4 ns
Differential input resistance, DC coupled	100 k $\Omega$ $\pm$ 2%
Differential input capacitance	< 0.3 pF at 100 MHz
Common-mode input resistance, DC coupled	50 k $\Omega$ $\pm$ 2% (per side)
Common-mode input capacitance	< 0.45 pF at 100 MHz (per side)
Input impedance	See Figure 12
Noise, referred to input	35 nV/ $\sqrt{\text{Hz}}$
DC Offset Scale Accuracy (gain of offset signal path)	$\pm$ 2.0%
DC Offset Drift	150 $\mu\text{V}/^\circ\text{C}$ or less at output of probe  0.75 $\text{mV}/^\circ\text{C}$ or less displayed on screen with TEKPROBE interface
DC Voltage Measurement Accuracy (referred to input)	$\pm$ [2% of input + (2% of offset) + 50.0 mV + 40.0 mV]  gain error = $\pm$ 2% of input voltage  offset gain error = $\pm$ 2% of effective offset at probe tip  output zero = $\pm$ 50 mV effective at probe tip  linearity error = $\pm$ 1.0% of 4.0 V dynamic range (40.0 mV)

Figure 11 shows the typical common-mode gain of the probe. The CMRR can be approximated by subtracting the common-mode gain from the -14 dB reference level. For example, -80 dB CM gain equals +66 dB CMRR.

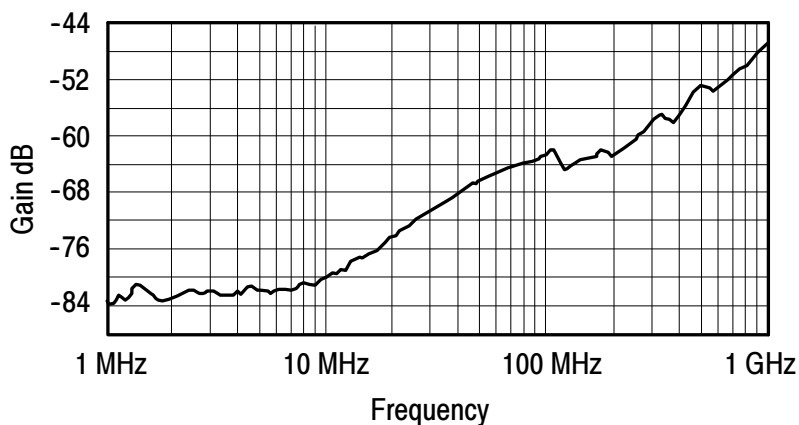

**Figure 11: Typical common-mode gain**

The graph in Figure 12 represents simulation results of a first order model of the probe input.

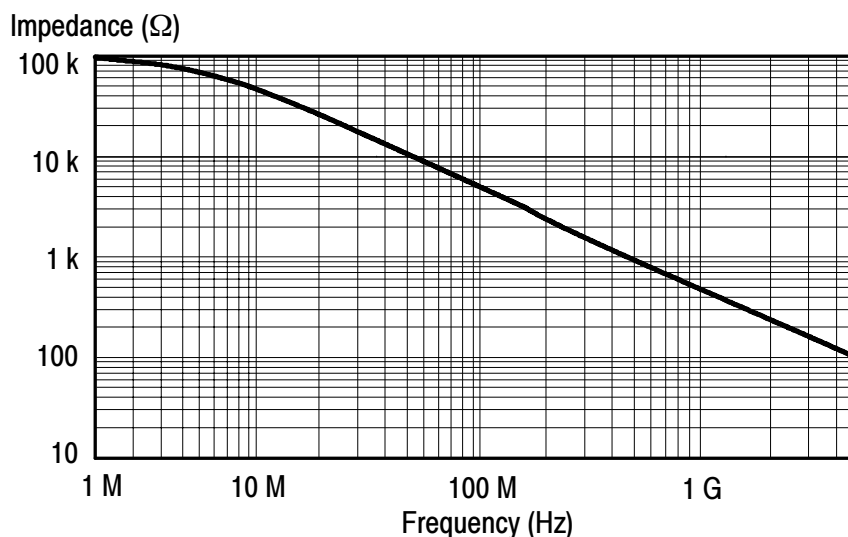
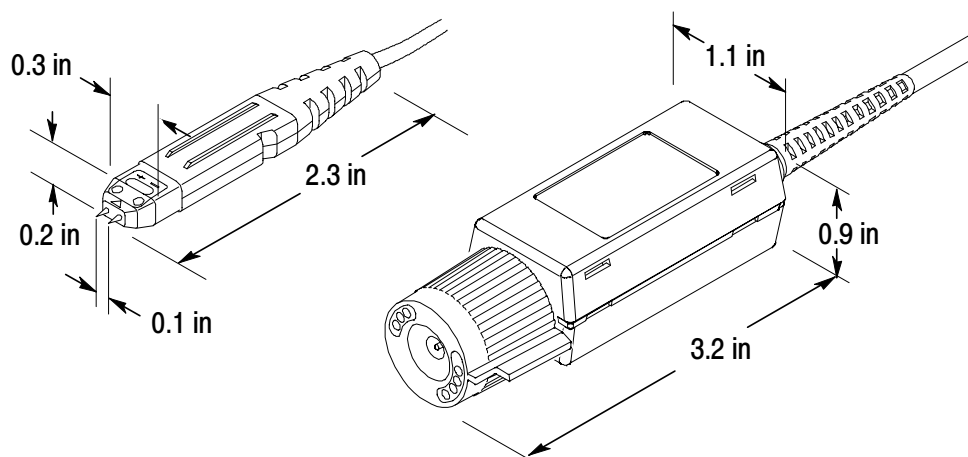

**Figure 12: Typical differential input impedance vs frequency**



**Table 5: Typical mechanical characteristics**

Dimensions, input connection	2.5 mm (0.99 in) pins on 2.54 mm (0.100 in) centers
Dimensions, control box	82 mm × 28 mm × 23 mm (3.2 in × 1.1 in × 0.9 in)
Dimensions, probe head	59 mm × 7.7 mm × 5.1 mm (2.3 in × 0.3 in × 0.2 in)
Dimensions, output cable	1.3 m (51 in)
Unit weight (probe only)	160 g (5.4 oz)



**Figure 13: Probe head and compensation box dimensions**

## Nominal Characteristics

Nominal characteristics (Table 6) describe guaranteed traits, but the traits do not have tolerance limits.

**Table 6: Nominal electrical characteristics**

Input configuration	Differential (two inputs, + and - ), with case ground
Attenuation	5X
Input coupling	DC
Termination	Terminate output into 50 $\Omega$



**WARNING**

***The following servicing instructions are for use only by qualified personnel. To avoid injury, do not perform any servicing other than that stated in the operating instructions unless you are qualified to do so. Refer to all safety summaries before performing any service.***



# Theory of Operation

There are no user replaceable parts within the probe or the compensation box; however, this theory of operation is provided to assist you in isolating failures to either the probe or the host oscilloscope. Refer to Figure 14 for a simplified schematic of the probe.

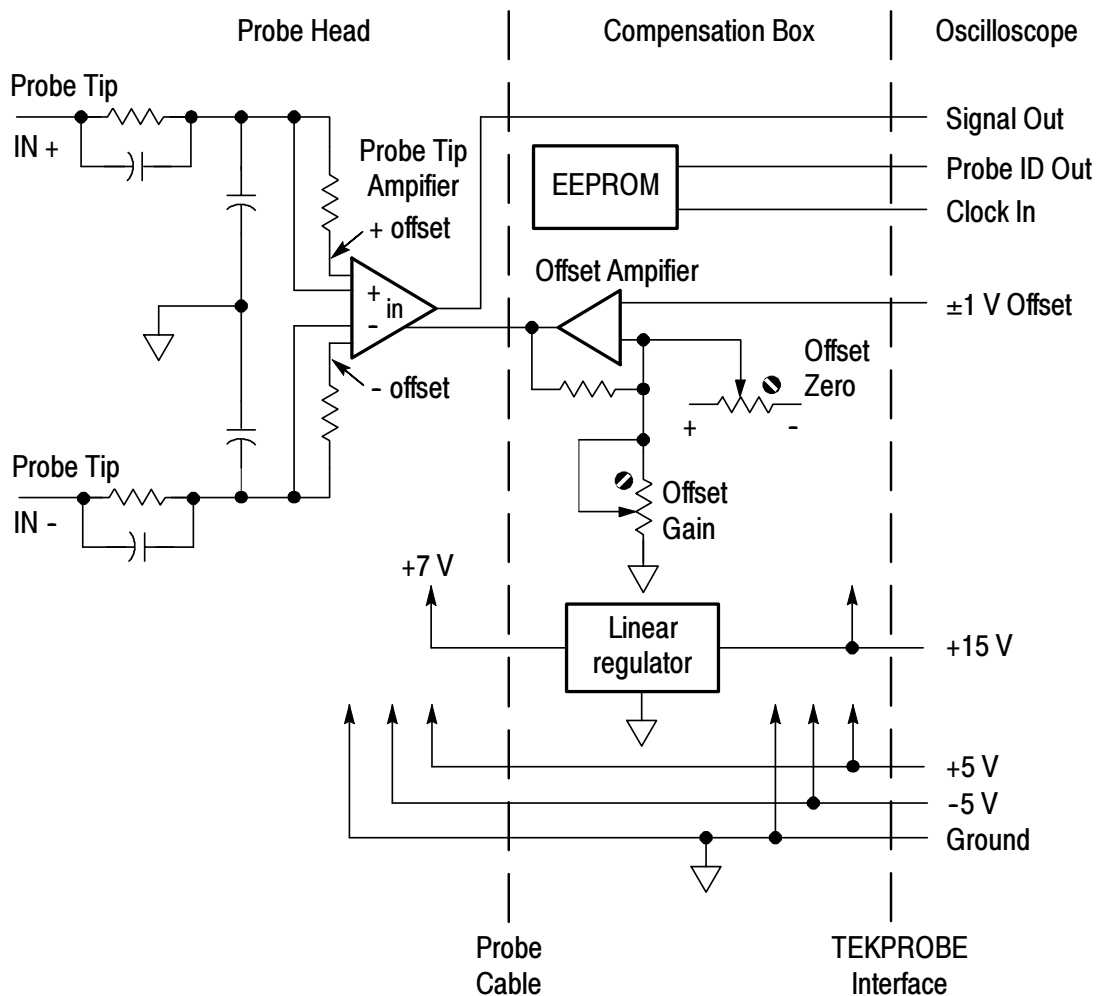

**Figure 14: Simplified schematic diagram**

## Probe Head and Cable Assembly

The probe head assembly contains an active amplifier circuit that buffers and amplifies the input signal. The amplifier receives power and an offset level from the compensation box assembly via the cable assembly.

All signal amplification and buffering is performed in the probe head assembly. No further amplification takes place in the compensation box.

## Compensation Box

The compensation box contains the following circuits:

- Offset amplifier
- Probe identification EEPROM
- TEKPROBE interface
- DC CMRR adjustment circuitry
- $V_{CC}$ , +7 V linear regulator

### Offset Amplifier

The offset amplifier is used to offset the DC component of the input signal so that it stays at the optimal point of the linear dynamic range of the probe.

The offset amplifier receives offset information as a  $\pm 1$  VDC voltage from the oscilloscope. The amplifier then amplifies it to match the probe characteristics and applies it to the probe hybrid circuit.

The offset amplifier has two adjustments: offset zero and offset gain. These adjustments rarely need attention; however, detailed adjustment instructions are in the *Adjustments* section on page 47.

### Probe Identification EEPROM

The probe identification EEPROM is used to configure the oscilloscope to the probe. The EEPROM receives a clock input from the oscilloscope, and information about the probe is passed to the oscilloscope.

### TEKPROBE Interface

The TEKPROBE interface provides a communication path between the probe and the oscilloscope. Contact pins provide power, signal, offset, and data transfer for the probe identification EEPROM.

Figure 15 shows the TEKPROBE interface pin functions. Refer to the service documentation for your oscilloscope for more detailed specifications.

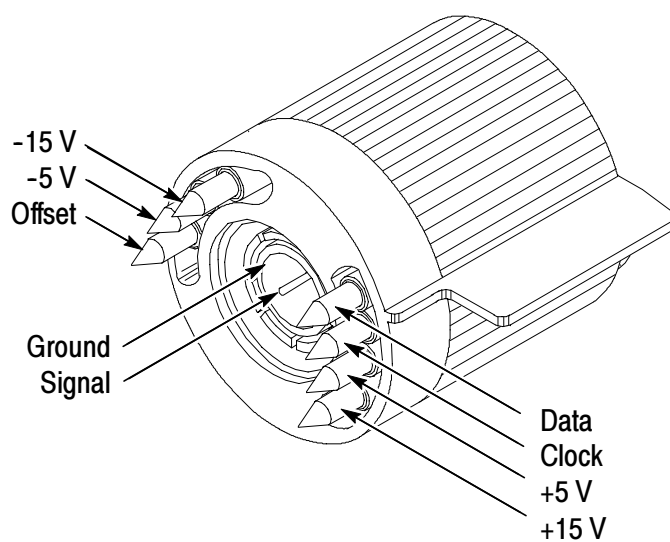

Figure 15: TEKPROBE interface





# Performance Verification

Use the following procedures to verify specifications of the P6330 probe. Before beginning these procedures, refer to page 46 and photocopy the test record, and use it to record the performance test results. The recommended calibration interval is one year.

These procedures test the following specifications:

- Output offset voltage
- DC gain accuracy
- Rise time

## Equipment Required

Refer to Table 7 for a list of the equipment required to verify the performance of your probe.

**Table 7: Equipment required for performance verification**

Item description	Performance requirement	Recommended example
High Speed Sampling Oscilloscope	10 GHz bandwidth	Tektronix TDS8000 with 80E04 module or 11800 with SD24 module
Probe Calibration Fixture	See page 39	067-0419-00
Probe Positioner		Tektronix PPM203B
Power Supply	TEKPROBE interface	Tektronix 1103
Power Supply	5.0 VDC at 1 mA	Tektronix PS280
DMM (2), with leads	0.1 mV resolution	Fluke 87 or equivalent
Feedthrough Termination	BNC, 50 $\Omega$ $\pm$ 0.05 $\Omega$	011-0129-00
Coaxial cables (2)	Male-to-Male SMA, 20 in	174-1427-00
Coaxial cable	Male-to-Male BNC, 50 $\Omega$	012-1342-00

**Table 7: Equipment required for performance verification (Cont.)**

<b>Item description</b>	<b>Performance requirement</b>	<b>Recommended example</b>
Precision coaxial cable	Male-to-Male SMA, 1 ns delay	015-0562-00
Adapter	SMA Female-to-Female	015-1012-00
Adapters (2)	SMA Female-to-BNC Male	015-0572-00
Adapter	SMA Male jack	131-7128-00
Adapter	BNC Female-to-Dual Banana	103-0090-00
Adapter	Square pin adapter	016-1884-00
Adapter	Y-lead adapter	196-3434-00
Adapters (2)	KlipChip adapter	206-0364-00

## Equipment Setup

Use this procedure to set up the equipment to test the probe.

1. Connect the probe to the 1103 power supply.
2. Turn on 1103 power supply.
3. Turn on the oscilloscope.
4. Allow 20 minutes for the equipment to warm up.

## Probe Calibration Fixture

Some of the procedures in this manual use a probe calibration fixture, Tektronix part number 067-0419-00.

The calibration fixture provides a means to test the probe for both common mode and differential mode measurements. SMA connectors allow stimulus signals to connect to the fixture and are located on the front and back of the fixture. The fixture is designed to be used with a probe positioner, such as a Tektronix PPM203B.

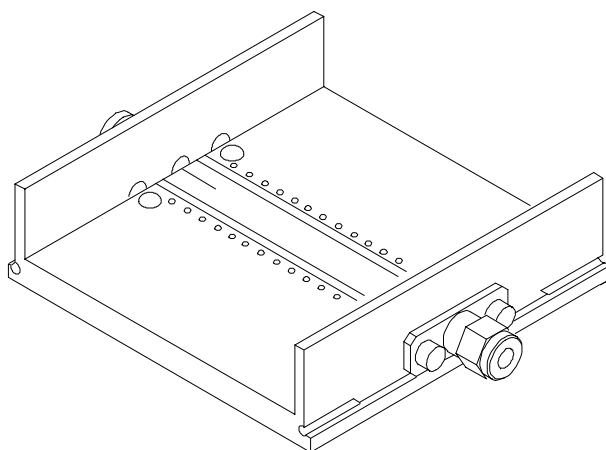
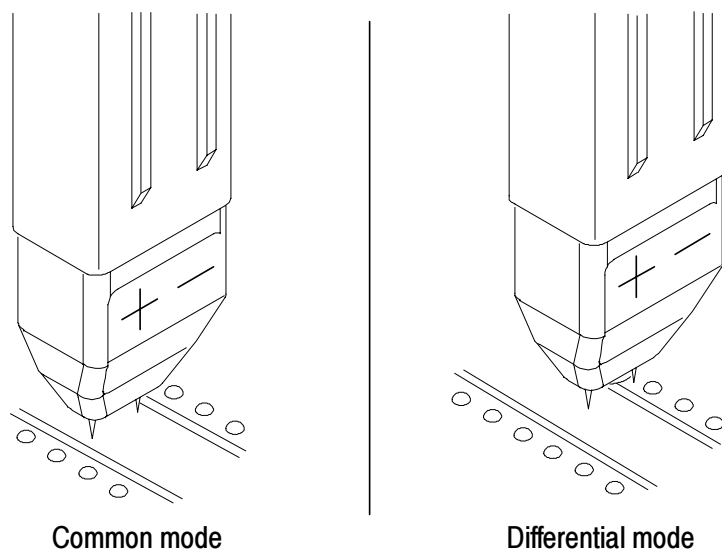

**Figure 16: Probe Calibration Fixture**

### Using the Probe Calibration Fixture

1. Connect the fixture to the test circuit using an SMA cable.
2. Connect the 50  $\Omega$  terminator included with the fixture to the unused SMA connector.
3. Insert and secure the probe in a probe positioner.
4. Position the probe over the fixture, using either the positioner coarse adjustment or otherwise manipulating the positioner arm in place.

- Using the fine position and/or pressure adjust, maneuver the probe so that the pins contact the CM or DM test points, depending on which test you are performing. (See Figure 17.)

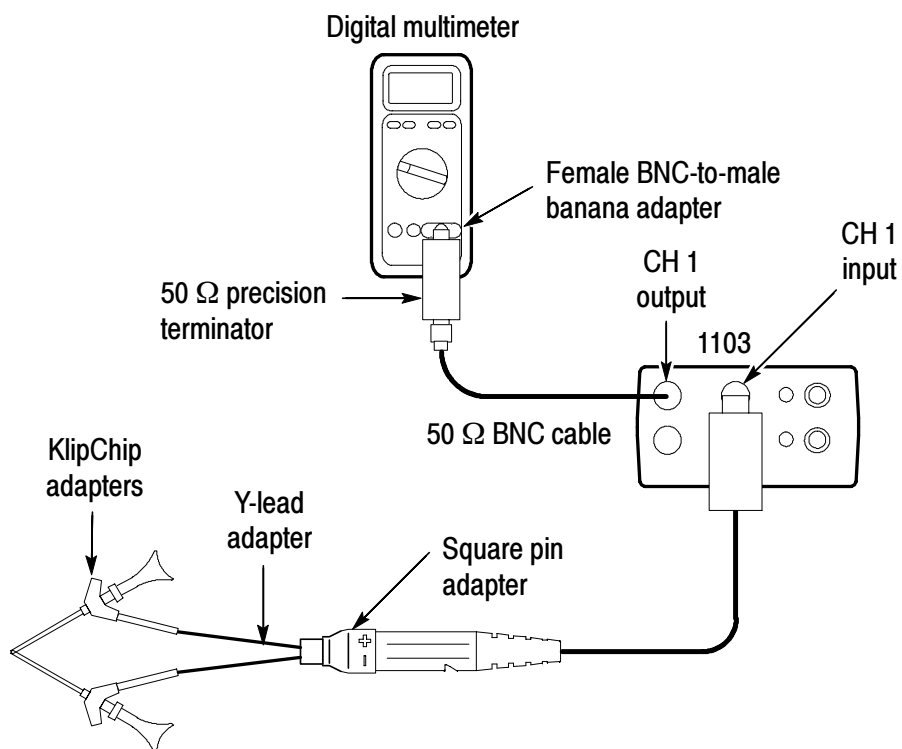

**Figure 17: Probe Calibration Fixture test points**

- Verify that contact is made on both pins. (You may need to readjust the fine position and/or pressure adjustment to make positive contact with the test points.)
- Proceed with the specific test instructions.

## Output Offset Voltage

1. Connect the probe as shown in Figure 18.

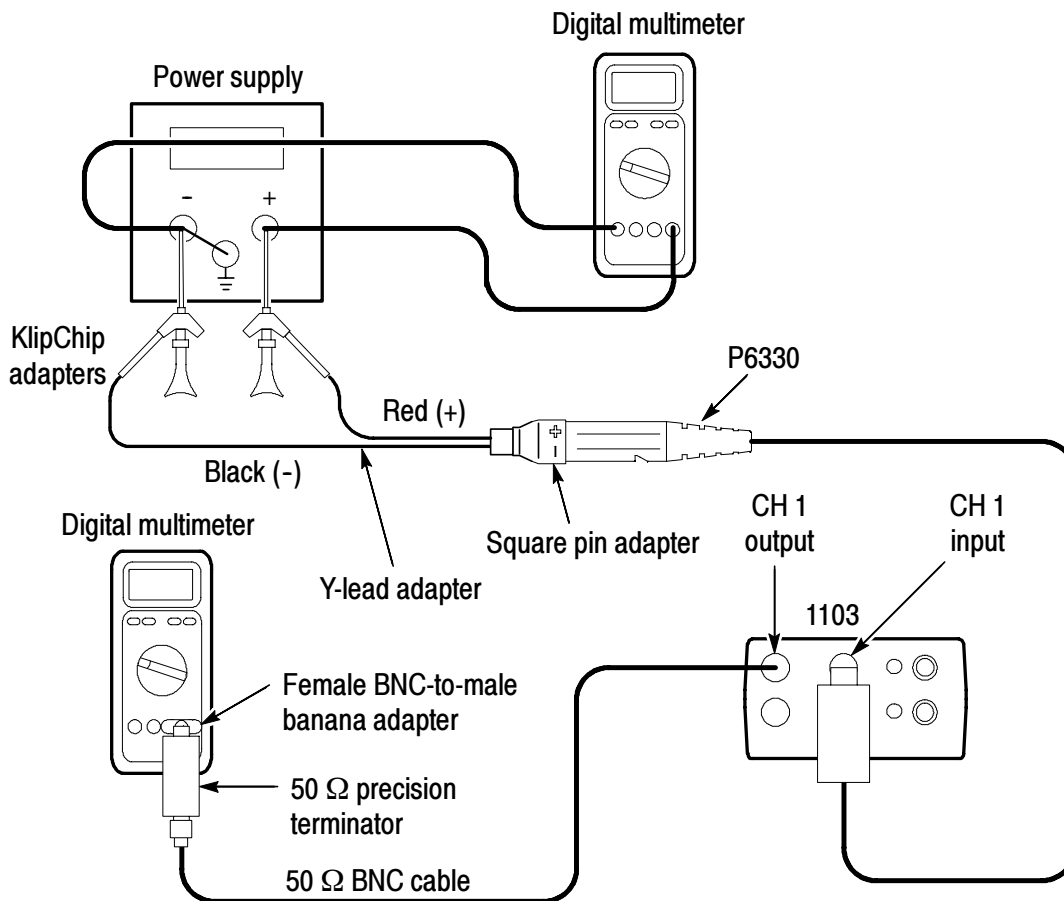

**Figure 18: Setup for the output offset voltage test**

2. Set the Var/0v button on the 1103 power supply to 0v (light off).
3. Verify that the output voltage is 0 V,  $\pm 10$  mV.

## DC Gain Accuracy

1. Connect the probe input to the DC source, as shown in Figure 19 on page 42. Monitor the source voltage with the DMM.
2. Set the input voltage on the DC source to approximately +0.5 V. Record the actual voltage as  $V_{in1}$ .



**Figure 19: DC Gain Accuracy setup**

3. Record the output voltage as  $V_{out1}$ .
4. Set the input voltage on the DC source to approximately  $-0.5$  V. Record the actual voltage as  $V_{in2}$ .
5. Record the output voltage as  $V_{out2}$ .
6. Calculate the gain as follows:  $(V_{out1} - V_{out2}) \div (V_{in1} - V_{in2})$ .
7. Verify that the gain is  $0.2, \pm 2\%$ .

## Rise Time

This procedure verifies that the probe meets rise time specifications. Two rise times are measured; the test system, and the test system with the probe included. The probe rise time is calculated using the two measurements.

1. Connect the test equipment as shown in Figure 20.

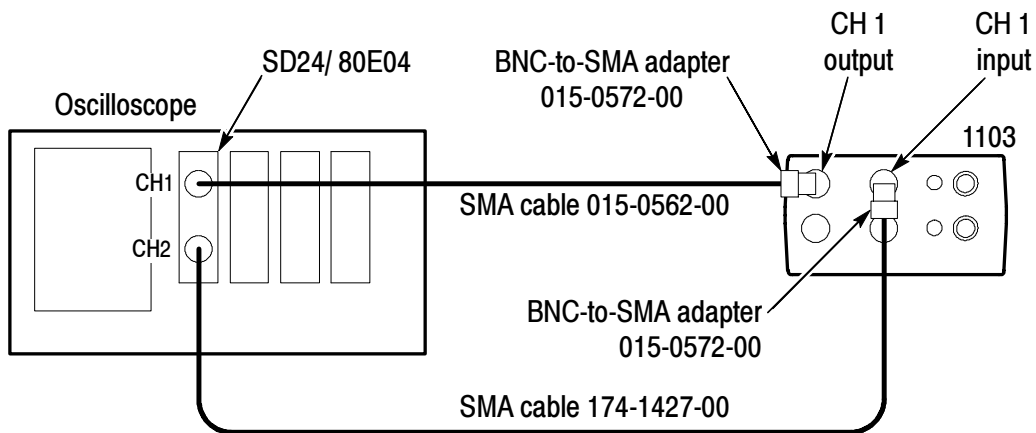

**Figure 20: Test system rise time setup**

2. Adjust the oscilloscope vertical sensitivity to 50 mV/div.
3. Turn on the TDR pulse on the SD-24 or TDS8000 (Ch 2).
4. Adjust the oscilloscope vertical positioning to center the signal on screen.
5. Adjust the oscilloscope horizontal sensitivity to 500 ps/div.
6. Adjust the oscilloscope horizontal positioning to place the rising edge of the signal where it crosses the second vertical and center horizontal graticule lines.
7. Use the oscilloscope measurement capability to display rise time. Rise time is determined from the 10% and 90% amplitude points on the waveform. Record the rise time as  $t_s$ .

If the measurement reading is not stable, use Average mode (16 Averages) to improve stability.

The system rise time ( $t_s$ ) that you measured in step 7 represents the rise time of the test system without the probe. The system rise time is used to calculate the probe rise time ( $t_p$ ) in step 16.

The following steps instruct you to assemble the test setup that includes the probe, as shown in Figure 21. The system and probe rise time ( $t_{s+p}$ ) that you measure in step 15 is used to calculate the probe rise time ( $t_p$ ) in step 16.

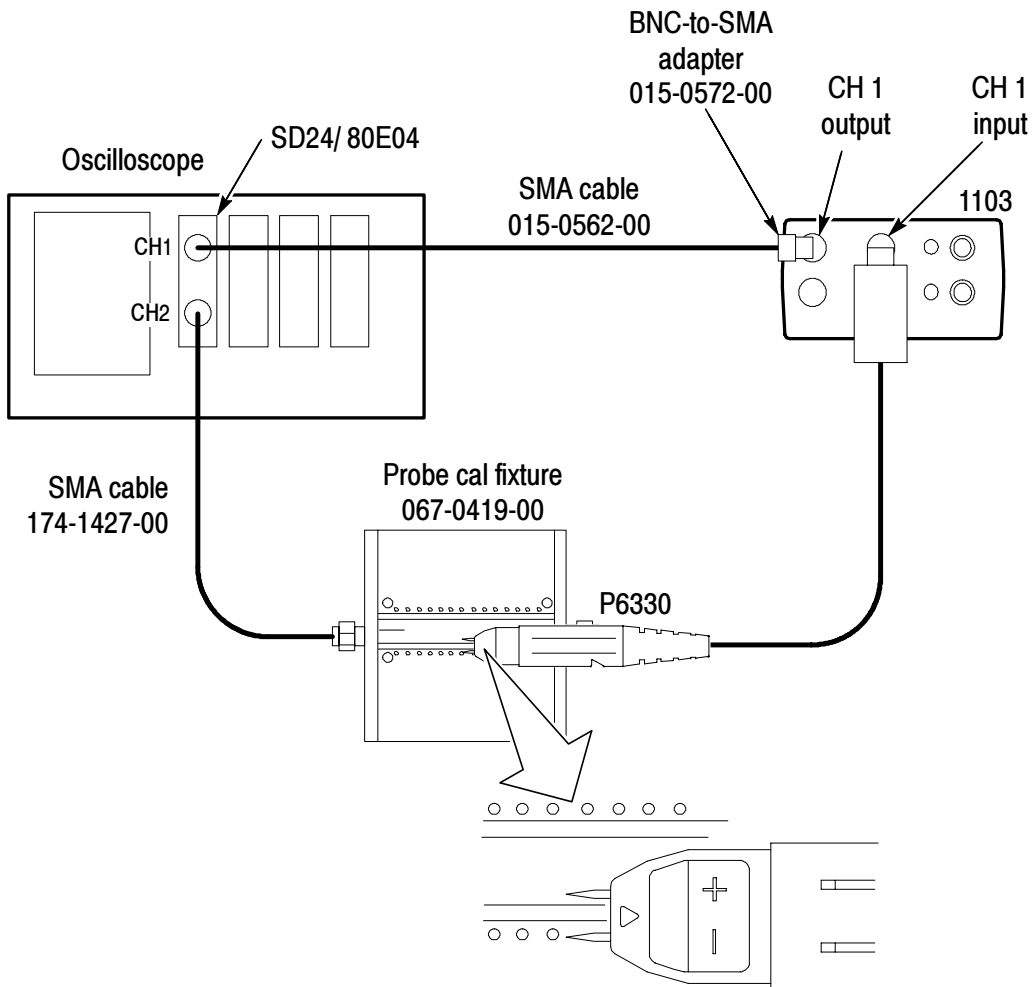

**Figure 21: Test system rise time setup with probe**



8. Disconnect the BNC-SMA adapter from the CH 1 input of the 1103 power supply and the SMA cable.
9. Connect the SMA cable to one input of the probe cal fixture, and the terminator to the other input of the probe cal fixture.
10. Connect the probe to the 1103 power supply channel 1 input.
11. Turn off the offset control on channel 1 of the 1103 power supply.
12. Using the probe positioner, probe the DM test points on the probe calibration fixture. Compare your display to Figure 22 to verify that you have a valid connection with both pins.

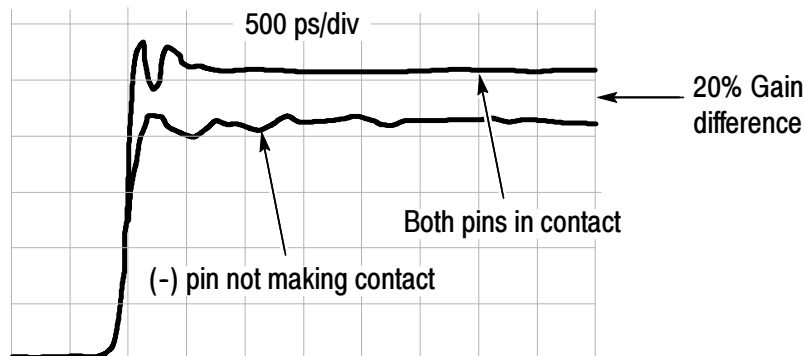

**Figure 22: Verifying both probe pins are contacting the DM test points**

13. Adjust the oscilloscope vertical scale to 10 mV/div, averaging on.
14. Adjust the oscilloscope horizontal positioning to place the rising edge of the signal so that it crosses the second vertical and center horizontal graticule lines.
15. Use the oscilloscope measurement capability to display rise time. Rise time is determined from the 10% and 90% amplitude points on the waveform. Record the rise time as  $t_{s+p}$ .
16. Calculate the probe rise time using the following formula:

$$t_p = \sqrt{t_{(s+p)}^2 - t_s^2}$$

17. Record the calculated probe rise time on the test record.

**Test record**

Probe Model: \_\_\_\_\_

Serial Number: \_\_\_\_\_

Certificate Number: \_\_\_\_\_

Temperature: \_\_\_\_\_

RH %: \_\_\_\_\_

Date of Calibration: \_\_\_\_\_

Technician: \_\_\_\_\_

Performance test	Minimum	Incoming	Outgoing	Maximum
Output offset voltage	- 10 mV	_____	_____	+ 10 mV
DC gain accuracy	- 2 %	_____	_____	+ 2 %
Rise time	N/A	_____	_____	≤140 ps

# Adjustments

The P6330 has 3 internal controls: offset zero, offset range, and DC CMRR. These controls should only be adjusted after a probe performance verification and functional check has been performed on the oscilloscope, and only if a check fails to meet its specification.

To make adjustments to the probe, the compensation box cover must be removed and the equipment allowed to warm up for 20 minutes.

## Equipment Required

In addition to the equipment required to perform the performance verification, the adjustment procedures require the equipment listed in Table 8.

**Table 8: Additional equipment required for adjustment**

<b>Item description</b>	<b>Recommended example</b>
Release tool	003-1383-00
Adjustment tool	003-0675-01

## Removing the Compensation Box Cover

Follow these steps to open the compensation box.

1. Press the optional release tool pins into the compensation box cover catches and gently lift the cover off a small distance. Refer to Figure 23.
2. Hold the open edge apart, and use the tool to open the other side of the compensation box.
3. With both sides of the box open, gently separate the two halves of the compensation box.

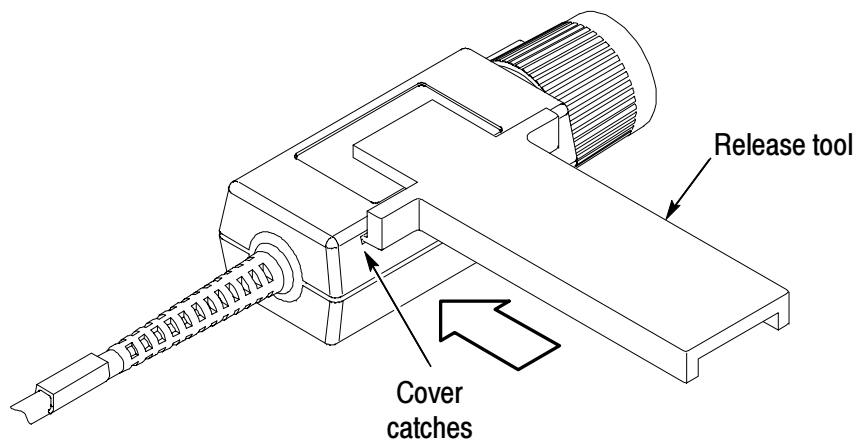

**Figure 23: Removing the compensation box cover**

Figure 24 shows the location of the adjustments and test points inside the compensation box. Refer to Figure 24 when performing the adjustment procedures in this section.

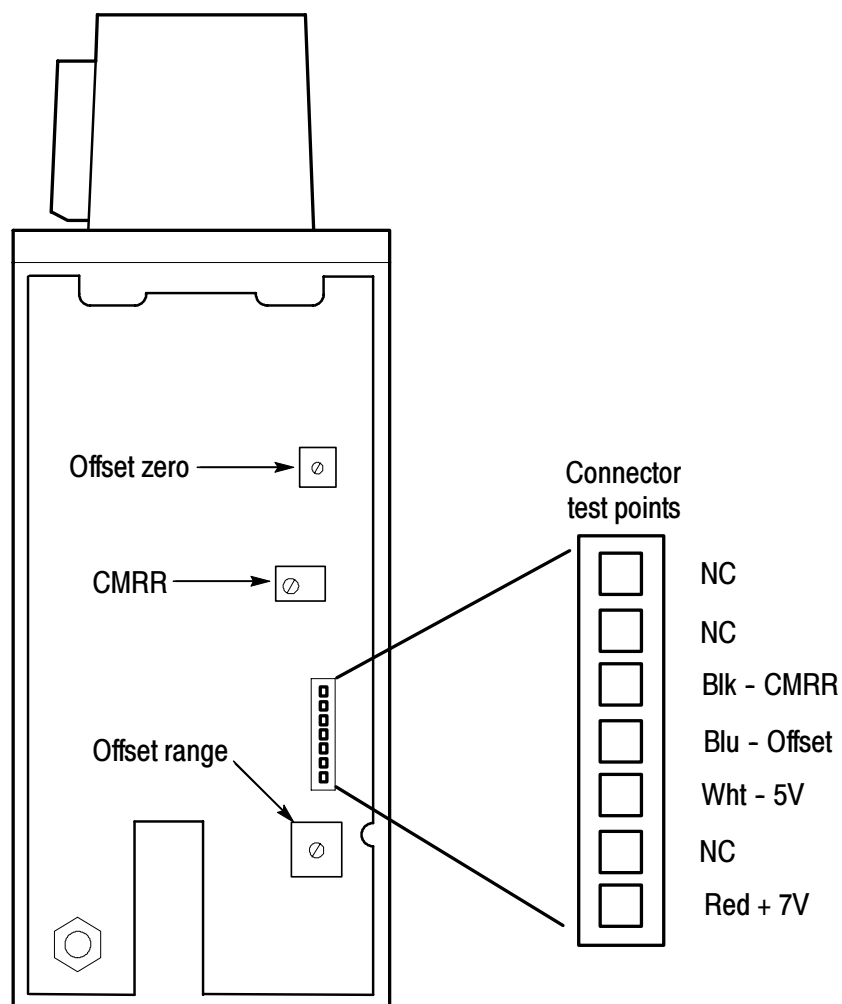

**Figure 24: Adjustment and test point locations**

## Offset Zero and DC CMRR

Use the following procedures to adjust the offset zero and DC CMRR characteristics of the probe. Due to the interaction of the two adjustments, it may be necessary to repeat the procedure to optimize the adjustments.

---

**NOTE.** *If your oscilloscope has a probe calibration routine, clear the probe calibration constants at this time.*

*If the offset zero is adjusted, perform a functional check of the offset range before closing the compensation box.*

---

1. Connect the probe tips together using the square pin, Y-lead, and KlipChip adapters.
2. Connect the probe as shown in Figure 18 on page 41.
3. Set the Var/0v button on the 1103 power supply to 0v (light off).

The output offset voltage is displayed on the DMM.

4. Adjust **Offset Zero** for 0.00 V  $\pm$ 3 mV, displayed on the DMM. Record the actual value.
5. Connect the probe as shown in Figure 25 on page 51. Monitor the source voltage with the DMM.

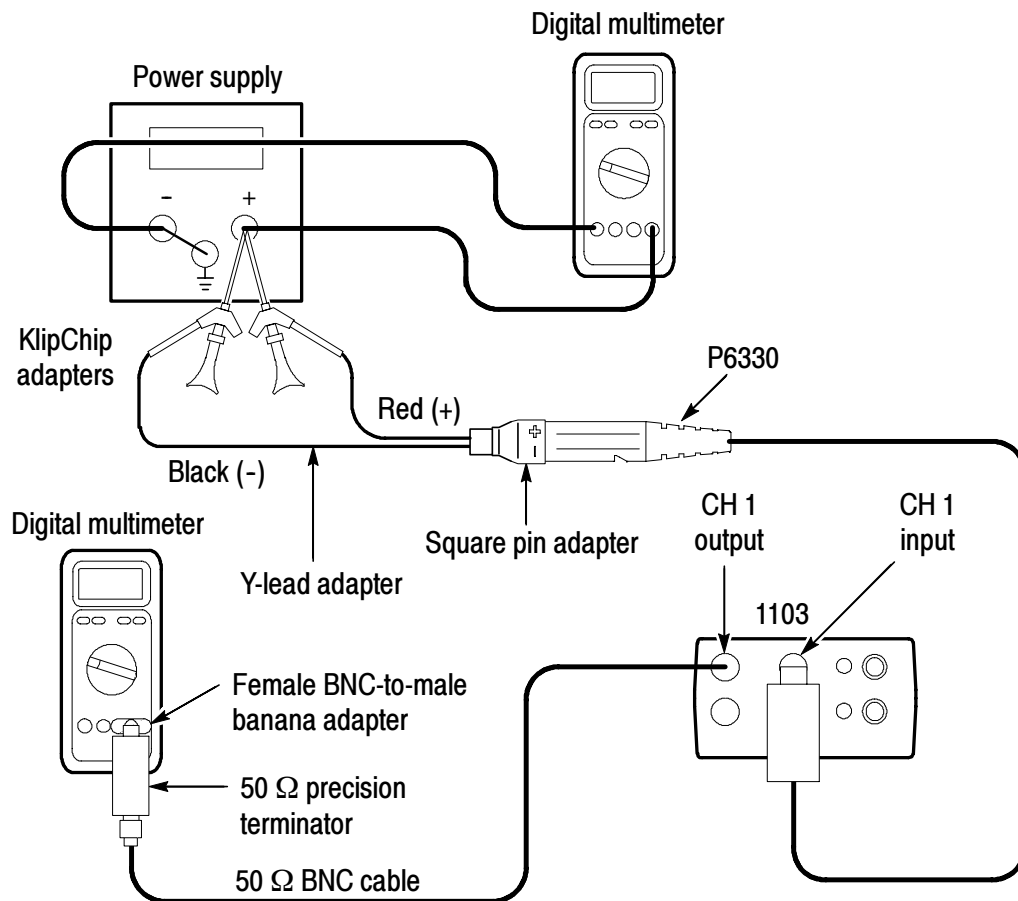

**Figure 25: Offset zero and DC CMRR setup**

6. Set the input voltage on the DC source to 3.0 V,  $\pm 10$  mV.
7. Adjust the CMRR control in the probe for an output equal to the value measured in step 4 on page 50,  $\pm 0.1$  mV.
8. Set the input voltage on the DC source to approximately +3.0 V. Record the actual voltage as  $V_{in1}$ .
9. Record the output voltage as  $V_{out1}$ .
10. Set the input voltage on the DC source to approximately -3.0 V. Record the actual voltage as  $V_{in2}$ .
11. Record the output voltage as  $V_{out2}$ .

- 12.** Calculate the common-mode gain ( $A_{CM}$ ) as follows:  
$$(V_{out1} - V_{out2}) \div (V_{in1} - V_{in2}).$$
- 13.** Calculate the CMRR as follows:  $20 \log (0.2/|A_{CM}|)$
- 14.** Reverify that the offset is 0 V,  $\pm 3.0$  mV (repeat steps 1 through 3). If the offset voltage magnitude is greater than 3.0 mV, or if the CMRR is less than 60 dB, disconnect the probe from the test circuit. Repeat the procedure, beginning with step 1 on page 50, to compensate for the adjustment interaction.



## Offset Range

Use this procedure to adjust the offset range of the probe. The offset zero of the probe must be measured before making any adjustment to the offset range. The offset zero voltage that you measure in the *Zero Offset* procedure (step 4 on page 50), is the target value that you adjust the offset range to. The offset range of the probe is approximately -1.0 to +1.0 volts. Take care not to disturb the power supply settings as you perform these procedures.

1. Connect the equipment as shown in Figure 26.
2. Power on the 1103 power supply and turn on the offset.
3. Refer to Figure 24 on page 49 for the location of the offset voltage test point. Using a second DMM, probe the test point and adjust the 1103 offset voltage to exactly -0.750 V.
4. Next, use the second DMM to set the DC power supply to exactly +0.750 V, measured at the output of the power supply.
5. Observe the DC value on the DMM connected to the 1103 power supply.

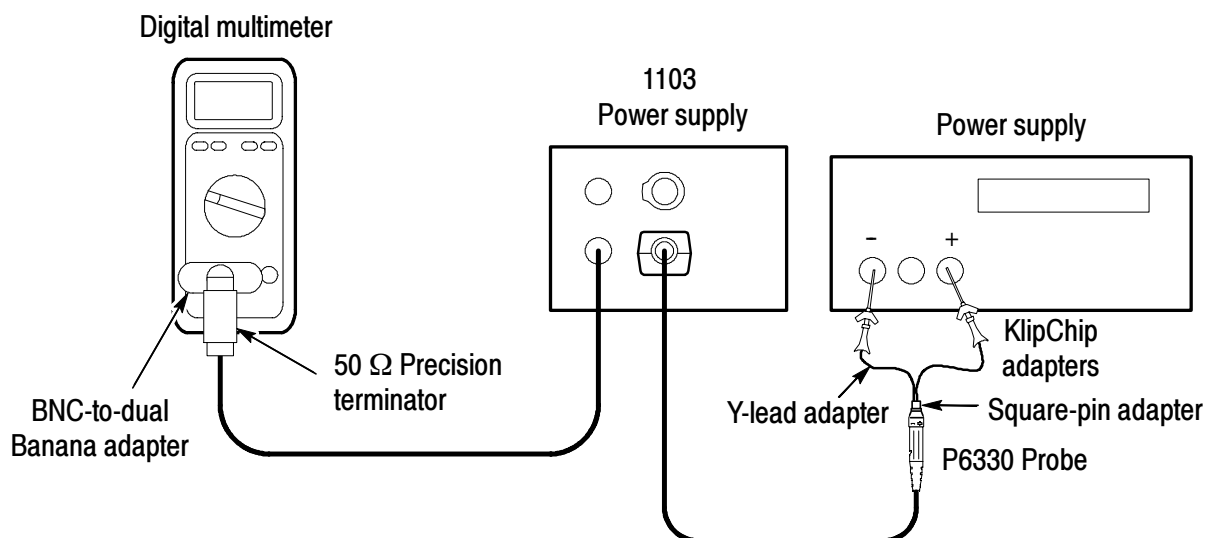

**Figure 26: P6330 offset range setup**

6. Adjust **Offset Range** for a DMM reading equal to the value set in the *Zero Offset* procedure (step 4 on page 50),  $\pm 3$  mV. Refer to Figure 24 on page 49 for the location of the offset range adjustment.

This completes the adjustments to the probe. Replace the compensation box cover and do a performance verification of the probe.

## Replacing the Compensation Box Cover

To replace the cover, follow these steps:

1. Align the TEKPROBE interface and the tab notches with the tabs on the cover. Refer to Figure 27.
2. Press the cover catches in so that the cover can be lowered.
3. Slide the tab into the notch.
4. Firmly press the pieces together until the cover catches snap into place.

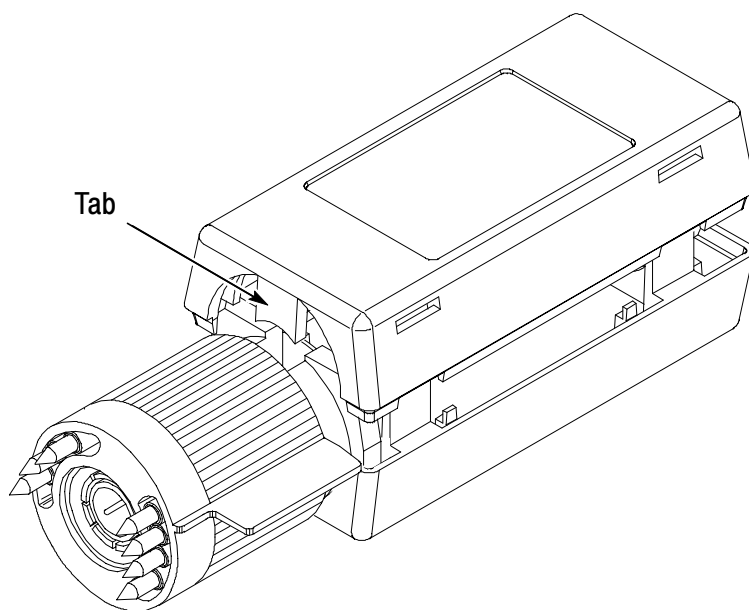

**Figure 27: Replacing the compensation box cover**

# Maintenance

This section details the maintenance and repair procedures for the P6330 differential probe.

## Replacing TEKPROBE Interface Pins

TEKPROBE interface pins can stick and fail to make contact after time. Periodically check to see that each of the interface pins move freely and fully extends out of the interface. If any pin fails to move freely and fully extend, it should be replaced.

To remove a TEKPROBE interface pin, firmly grasp the pointed tip with pliers and pull the pin out of the connector. See Figure 28.

No tools are required to install a replacement pin. Insert a new pin into the connector socket as far as possible using finger pressure. If necessary, seat the pin into the connector by pressing the tip gently but firmly against a hard surface, such as a wood block or table top.

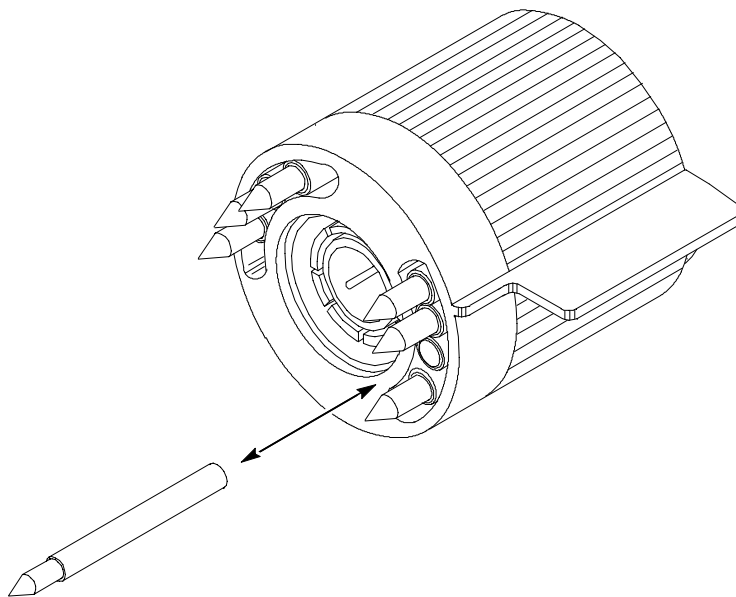

**Figure 28: Replacing TEKPROBE interface pins**

## Removing and Replacing the TEKPROBE Interface Collar

To remove the TEKPROBE interface collar, firmly grasp the compensation box body with one hand and the TEKPROBE interface collar with the other hand. Firmly pull the interface collar off.

To replace the collar, first note the pin configuration on the compensation box and their holes in the interface collar. The group of three pins fit through the smaller of the two holes in the interface collar. See Figure 29.

Align the tab to the slot, and gently press the two pieces together. See Figure 29.

Once installed, the TEKPROBE collar should rotate freely to lock and unlock.

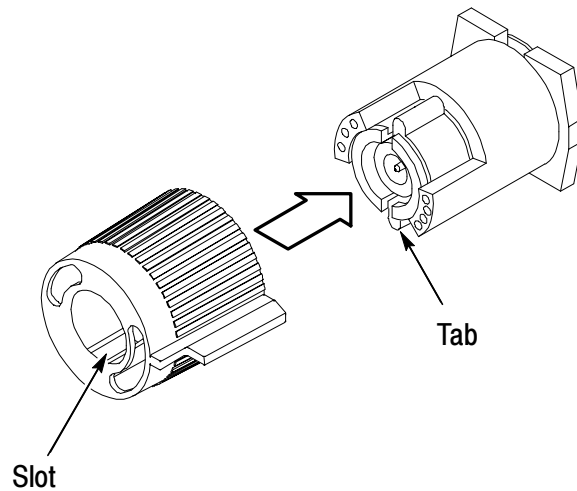

**Figure 29: Replacing the TEKPROBE interface collar**

## Inspection and Cleaning

To prevent damage to probe materials, avoid using chemicals that contain benzine, benzene, toluene, xylene, acetone, or similar solvents.

Do not immerse the probe or use abrasive cleaners.

Dirt may be removed with a soft cloth dampened with a mild detergent and water solution, or isopropyl alcohol.

## Replacement Parts

Refer to the *Replaceable Parts* section for a list of customer replacement parts. Due to the sophisticated design of the P6330, there are no user replaceable parts within the probe.

## Preparation for Shipment

If the original packaging is unfit for use or not available, use the following packaging guidelines:

1. Use a corrugated cardboard shipping carton having inside dimensions at least one inch greater than the probe dimensions. The box should have a carton test strength of at least 200 pounds.
2. Put the probe into an antistatic bag or wrap to protect it from dampness.
3. Place the probe into the box and stabilize it with light packing material.
4. Seal the carton with shipping tape.



## Replaceable Parts

This section contains a list of replaceable parts for the P6330 differential probe. Use this list to identify and order replacement parts.

### Parts Ordering Information

Replacement parts are available from or through your local Tektronix, Inc. service center or representative.

Changes to Tektronix instruments are sometimes made to accommodate improved components as they become available and to give you the benefit of the latest circuit improvements. Therefore, when ordering parts, it is important to include the following information in your order:

- Part number
- Instrument type or model number
- Instrument serial number
- Instrument modification number, if applicable

If a part you order has been replaced with a different or improved part, your local Tektronix service center or representative will contact you concerning any change in the part number.

## Using the Replaceable Parts List

The tabular information in the Replaceable Parts List is arranged for quick retrieval. Understanding the structure and features of the list will help you find the information you need for ordering replacement parts.

### Item Names

In the Replaceable Parts List, an Item Name is separated from the description by a colon (:). Because of space limitations, an Item Name may sometimes appear as incomplete. For further Item Name identification, U.S. Federal Cataloging Handbook H6-1 can be used where possible.

### Indentation System

This parts list is indented to show the relationship between items. The following example is of the indentation system used in the Description column:

<i>1</i>	<i>2</i>	<i>3</i>	<i>4</i>	<i>5</i>	<i>Name &amp; Description</i>
					<i>Assembly and/or Component</i>
					<i>Attaching parts for Assembly and/or Component</i>
					<i>(END ATTACHING PARTS)</i>
					<i>Detail Part of Assembly and/or Component</i>
					<i>Attaching parts for Detail Part</i>
					<i>(END ATTACHING PARTS)</i>
					<i>Parts of Detail Part</i>
					<i>Attaching parts for Parts of Detail Part</i>
					<i>(END ATTACHING PARTS)</i>

Attaching parts always appear at the same indentation as the item it mounts, while the detail parts are indented to the right. Indented items are part of, and included with, the next higher indentation. Attaching parts must be purchased separately, unless otherwise specified.

### Abbreviations

Abbreviations conform to American National Standards Institute (ANSI) standard Y1.1



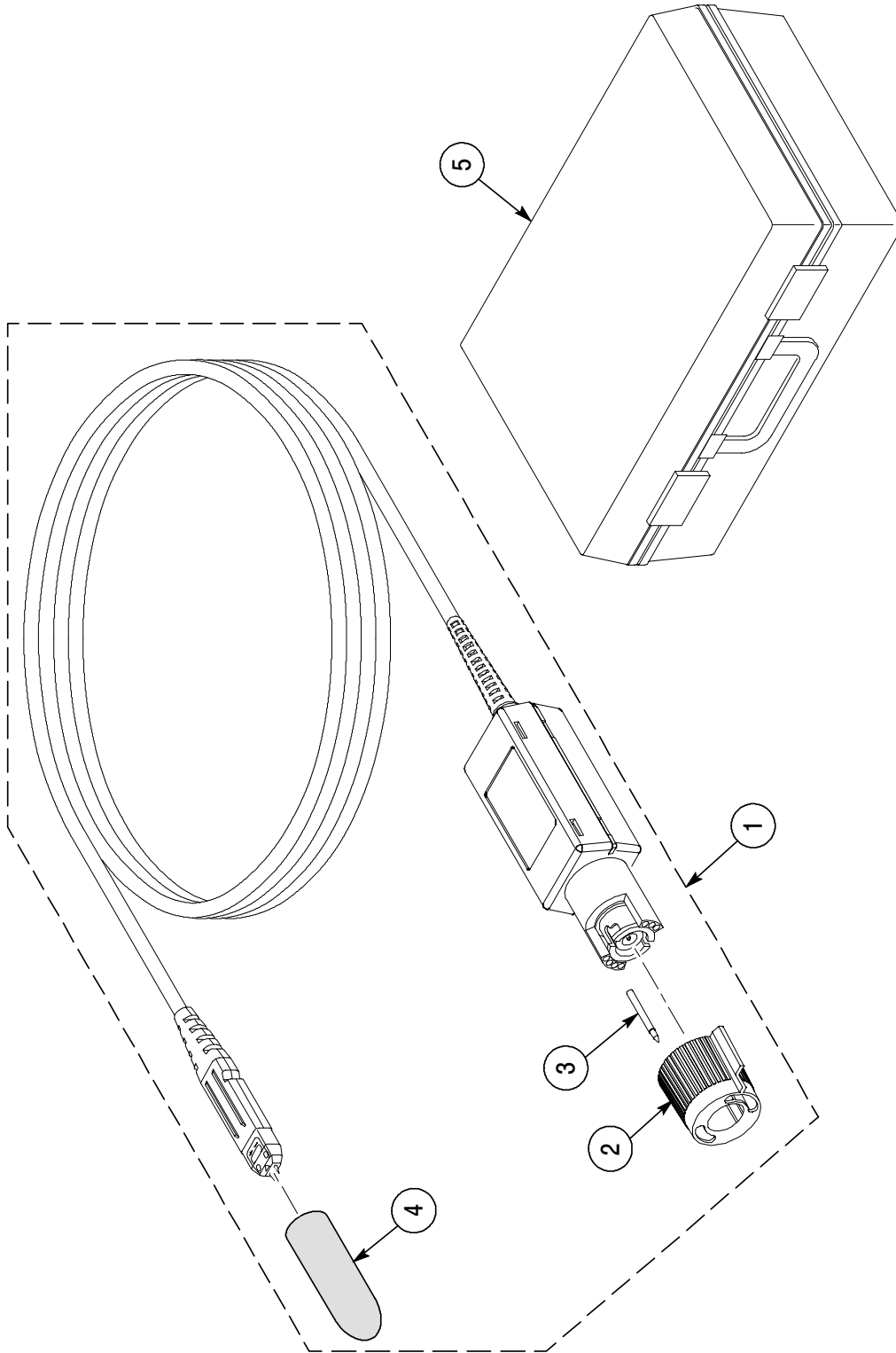

Figure 30: P6330 replaceable parts

## Replaceable Parts

---

Fig. & index no.	Tektronix part no.	Serial no. Effective	Qty	12345 name & description	Mfr. code	Mfr. part no.
30-1	010-0640-04		1	PROBE ASSEMBLY:SERVICE REPLACEMENT, SERIALIZED	80009	010-0640-04
-2	205-0191-XX		1	SHELL,ELEC CONN:BNC,ABS,DOVE GRAY	80009	205-0191-XX
-3	131-3627-02		1	CONTACT,ELEC:GOLD PLATED TIP	80009	131-3627-02
-4	200-4236-00		1	COVER, PROBE TIP	80009	200-4236-00
-5	016-1879-XX		1	CASE,STORAGE:PLASTIC,W/ANTISTAT FOAM	TK6108	016-1879-XX

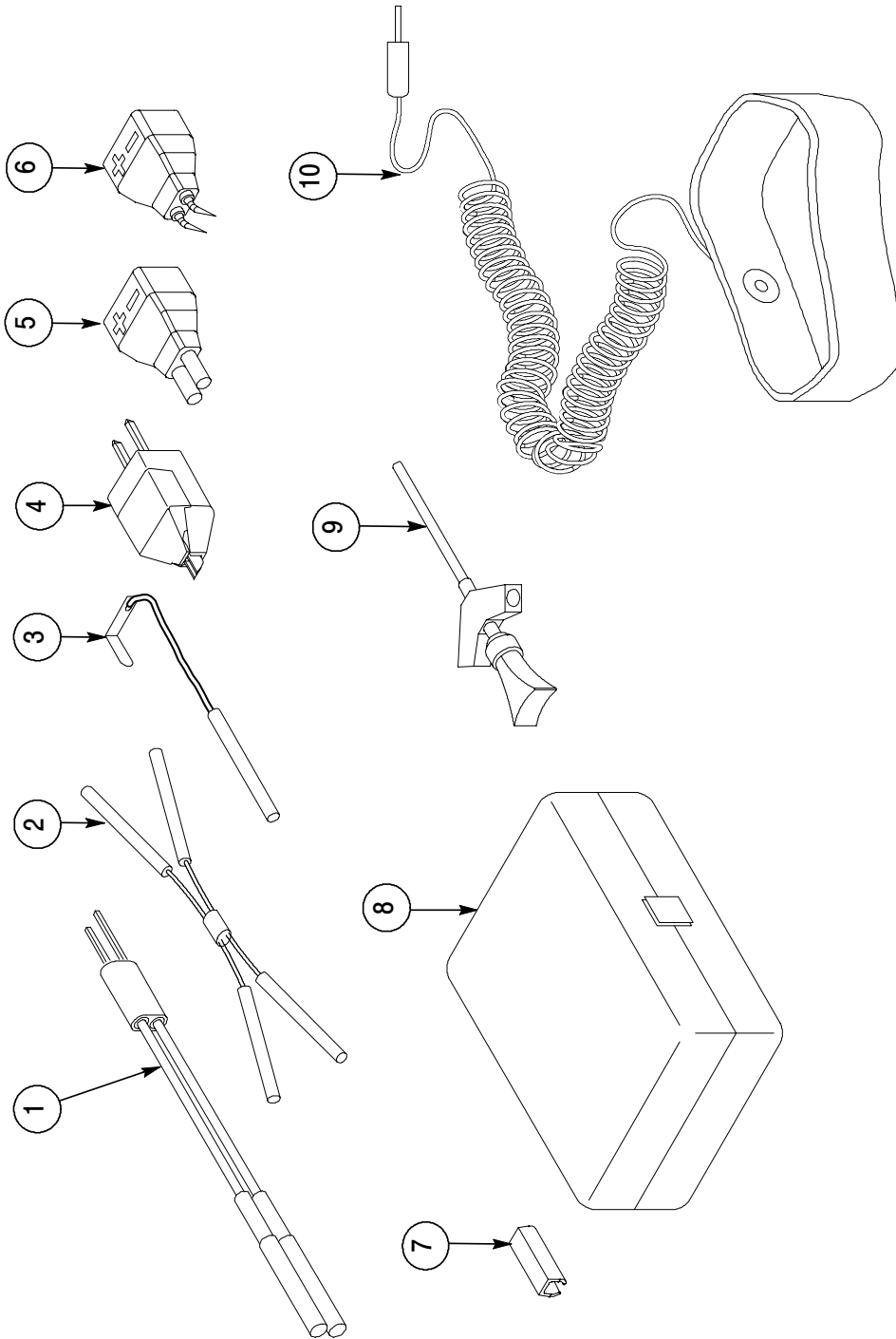

Figure 31: P6330 standard accessories

Fig. & index no.	Tektronix part no.	Serial no. Effective	Qty	12345 name & description	Mfr. code	Mfr. part no.
<b>STANDARD ACCESSORIES</b>						
31-1	196-3434-00		2	LEAD, ELEC:DESCRETE, CPD,2,22 AWG, RED & BLACK,2.300 L,1X2,0.1CTR,0.025 SQ PIN X 2,JACK TIP	060D9	196-3434-00
-2	196-3473-00		2	LEAD,PIN JUMPER:DIFF,FEMALE SQ PIN CONNECTOR TO FEMALE SQ PIN CONNECTOR,23 AWG,3.0 L	060D9	196-3473-00
-3	196-3465-00		2	LEAD GROUND:GROUND LEAD		196-3465-00
-4	016-1785-00		1	ADAPTER:DIFFERENTIAL PROBE,PKG OF 4	80009	016-1785-00
-5	016-1884-00		1	ACCESSORY KIT:SQUARE PIN ADAPTER,PKG OF 4	060D9	016-1884-00
-6	016-1885-00		1	ACCESSORY KIT:VARIABLE SPACER ADAPTER,PKG OF 4	060D9	016-1885-00
-7	016-1315-00		1	MARKER KIT,ID:CABLE MARKER BAND,2 EA, VAR COLRS	80009	016-1315-00
-8	006-7164-00		1	BOX,PLASTIC:4.625 X 2.875 X 1.0	80009	006-7164-00
-9	206-0364-XX		2	TIP,PROBE:MICROCKT TEST,SMT KLIPCHIP	80009	206-0364-XX
-10	006-3415-04		1	STRAP,WRIST:3M TYPE 2214, ADJUSTABLE,6 FT COILED CORD	TK0623	RTI 8454001829
	071-0757-XX		1	MANUAL,TECH:INSTRUCTION,P6330	80009	071-0757-XX

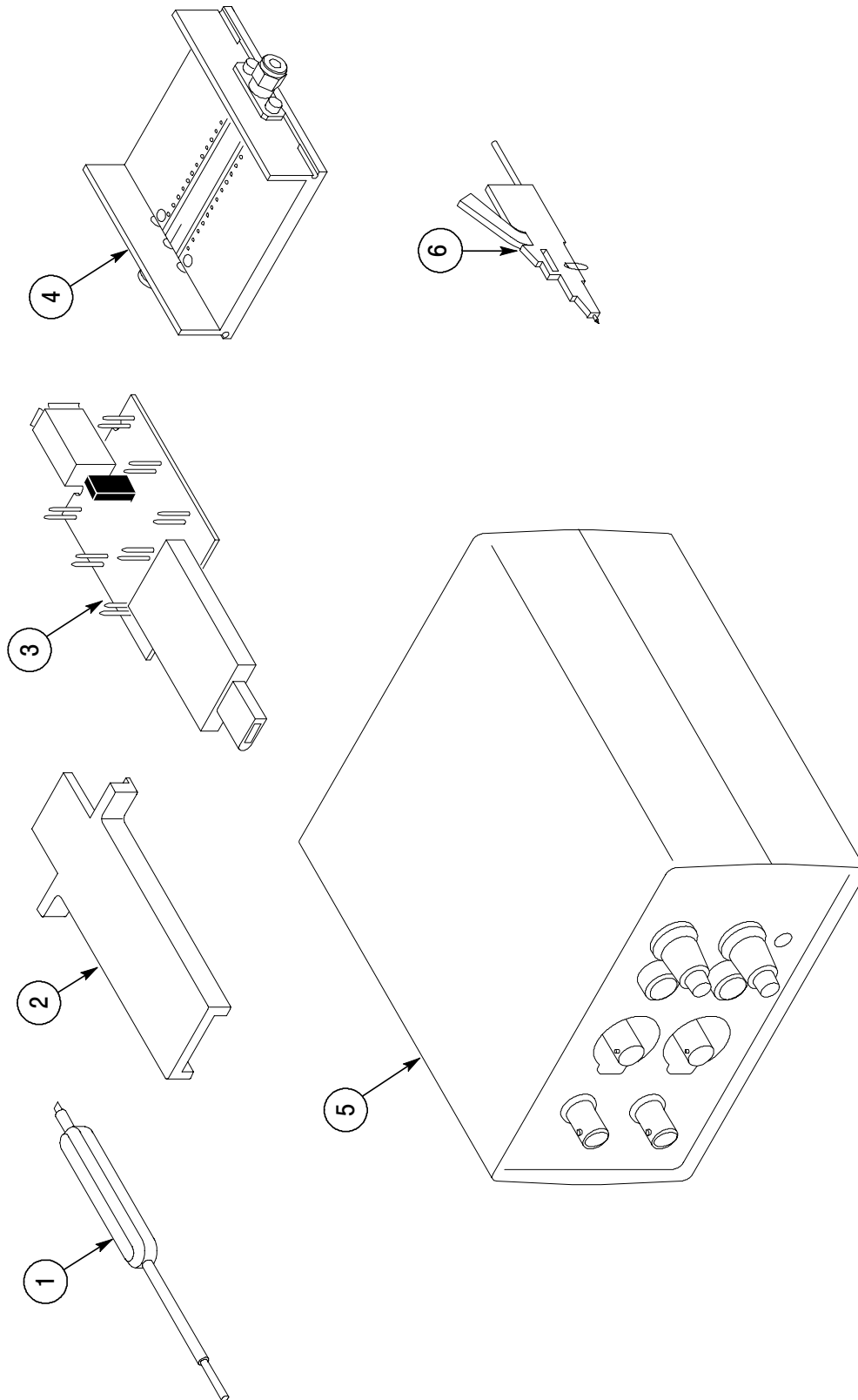

Figure 32: P6330 optional accessories

Fig. & index no.	Tektronix part no.	Serial no. Effective	Dscont	Qty	12345 name & description	Mfr. code	Mfr. part no.
<b>OPTIONAL ACCESSORIES</b>							
32-1	003-0675-01			1	ADJUSTMENT TOOL,PLASTIC,BLACK	TK2565	003-0675-01
2	003-1383-00			1	RELEASE TOOL	80009	003-1383-00
3	679-5027-00			1	CKT BD SUBASSY:1394 ADAPTER	80009	679-5027-00
4	067-0419-00			1	PROBE CALIBRATION FIXTURE	80009	067-0419-00
5	1103			1	TEKTRONIX 1103 TEKPROBE POWER SUPPLY	80009	ORDER BY DESCRIPTION
6	SMK4			1	TIP,PROBE:MICROCKT TEST,PKG OF 4	80009	SMK4
	SMG50			1	MICROCKT TEST,SMT KLIPCHIP,PKG OF 20 (SEE 31-9)	80009	SMG50

**CROSS INDEX - MFR. CODE NUMBER TO MANUFACTURER**

<b>Mfr. code</b>	<b>Manufacturer</b>	<b>Address</b>	<b>City, state, zip code</b>
060D9	UNITREK CORPORATION	3000 COLUMBIA HOUSE BLVD, SUITE 120	VANCOUVER, WA 98661
80009	TEKTRONIX INC	14150 SW KARL BRAUN DR PO BOX 500	BEAVERTON, OR 97077-0001
TK0623	GENERAL TOOL & SUPPLY CO	2705 NW NICOLAI ST	PORTLAND, OR 97210
TK2565	VISION PLASTICS INC	26000 SW PARKWAY CENTER DRIVE	WILSONVILLE, OR 97070
TK6108	KENT H LANDSBERG CO	27929 SW 95TH, SUITE 101	WILSONVILLE, OR 97070

