

# A Guide to Calibrating Your Spectrum Analyzer

## Application Note

### Introduction

As a technician or engineer who works with electronics, you rely on your spectrum analyzer to verify that the devices you design, manufacture, and test—devices such as cell phones, TV broadcast systems, and test equipment—are generating the proper signals at the intended frequencies and levels. For example, if you work with cellular radio systems, you need to ensure that carrier signal harmonics won't interfere with other systems operating at the same frequencies as the harmonics; that intermodulation will not distort the information modulated onto the carrier; that the device complies with regulatory requirements by operating at the assigned frequency and staying within the allocated channel bandwidth; and that unwanted emissions, whether radiated or conducted through power lines or other wires, do not impair the operation of other systems.

All of these measurements can be verified with a spectrum analyzer, which displays the frequency content of the signal generated by a device. But the performance of spectrum analyzer circuits can drift over time and under changing temperature conditions. This drift affects the accuracy of the analyzer's measurements. If the analyzer's measurements are not accurate, the devices you are testing with it may not perform as intended.

Since you use your spectrum analyzer to test other equipment, you need to have confidence in its measurements. Confidence, both that a device that tests out as good really is operating properly, and that a device that tests out as having problems really does not meet requirements. A high level of confidence is especially important these days, as more signals are crowded into the same space, making even small deviations capable of causing problems. This is why it is important to calibrate your spectrum analyzer at the intervals specified by the manufacturer and why it is vital that all critical spectrum analyzer functional parameters are tested to make sure they are operating within specification.

Spectrum analyzers are often perceived as being complex products that are time-consuming to calibrate. It is true that the procedure can take several hours or even days and requires an array of equipment, including signal sources, sophisticated reference standards, and accessories. However, calibration time can be significantly reduced by simply automating the verification process.

Another issue with spectrum analyzer calibration is the difficulty of interpreting the test results.

For example, the test for noise sidebands that determines whether the spectrum analyzer meets its phase noise specification often expresses the results in dBc, while analyzer specifications are typically quoted in dBc/Hz. Consequently, the test engineer must convert dBc to dBc/Hz as well as applying several correction factors to determine whether the spectrum analyzer is in compliance with specifications.

For these reasons, spectrum analyzer calibration is a task best handled by skilled metrologists, who have both the necessary equipment and an in-depth understanding of the procedures involved. Still, it's helpful for everyone who works with spectrum analyzers to understand the value of calibrating these instruments. This application note is intended both to help application engineers who work with spectrum analyzers understand the importance of regular calibration and to explain to calibration lab metrologists the key steps in calibrating a spectrum analyzer. It begins with a brief recap of what a spectrum analyzer is and what it does and then goes on to describe several of the most important tests needed to keep your spectrum analyzer operating within specifications.

### Table of Contents

<b>Introduction</b> .....	1
<b>What is a spectrum analyzer?</b> .....	2
<b>What does a spectrum analyzer measure?</b> .....	3
<b>Which calibration tests are needed?</b> .....	4
Display Linearity test.....	5
Noise Floor test .....	6
Input Attenuator test.....	7
Absolute Amplitude Accuracy and Frequency Response test .....	8
Resolution Bandwidth and Selectivity test.....	9
Resolution Bandwidth Switching test.....	10
Reference Level Accuracy test.....	11
Noise Sideband test .....	12
Residual FM test .....	13
Frequency Span test .....	14
Sweep Time Accuracy test.....	15
Harmonic Distortion test.....	16
Third-Order Intermodulation Intercept test.....	17
Gain Compression test.....	17
<b>Complexity reduction and automation</b> .....	18
<b>Conclusion</b> .....	19
<b>References</b> .....	19

## What is a spectrum analyzer?

There are several types of spectrum analyzers, ranging from low-cost entry-level handheld devices and traditional analog analyzers to modern, high-performance analyzers employing digital signal processing techniques. In this application note, we concentrate on the swept-tuned, superheterodyne spectrum analyzer. However, it should be noted that real-time spectrum analyzers have a significantly different architecture and while requiring some specific tests, they also share many of the calibrations described in this application note.

Figure 1 shows the key components that make up a typical swept tuned, superheterodyne spectrum analyzer. Its architecture resembles that of an AM superheterodyne receiver, in which a mixer is used to down-convert the input signal to a lower, intermediate frequency (IF) for processing. Most spectrum analyzers use two or three stages of down-conversion, but a single conversion is shown here for simplicity.

As the figure illustrates, a swept tuned, superheterodyne spectrum analyzer typically consists of the following components:

- An **RF input attenuator**, which reduces the amplitude of high-level input signals to prevent the mixer from being overloaded.
- A **mixer**, which combines the input and local oscillator frequencies to frequency shift the input signal as the local oscillator sweeps, allowing a narrow band of input frequencies to pass through the IF gain amplifier and filter for measurement.
- A variable **IF gain** circuit, which amplifies the mixer output before passing it to the IF filter, which then filters out the signals of interest. It is important that this gain be variable to allow the reference level at the top of the display to correspond to the required input signal level.
- An **IF filter**, which is a bandpass filter whose bandwidth is adjustable from the spectrum analyzer's front panel. This bandwidth, referred to as IF bandwidth or resolution bandwidth, determines how well input signals with small frequency differences can be distinguished from each other.
- A **detector/log amplifier**, which responds to the IF signal level, performing a logarithmic conversion to obtain a display scaled in dB per division.
- A **video filter** (sometimes abbreviated as VBW, for video bandwidth), which uses low-pass filtering to average and smooth the displayed trace.
- A **display**, which shows the spectrum of the measured input signal. As the local oscillator sweeps, the spectrum analyzer digitizes the measured signal levels and stores them for subsequent display as a complete spectrum. (Older analyzers without digital storage used long-persistence CRT displays that displayed the spectrum trace as the sweep progressed.)
- A **sweep generator**, which controls the frequency of the local oscillator and the refresh rate on the analyzer display.
- A **local oscillator**, which can be swept to generate the normal display or held constant in zero-span mode. With modern analyzers, which use frequency synthesizers as the local oscillator, the resolution of the synthesizer setting will influence the accuracy of both the display and the cursor frequency.

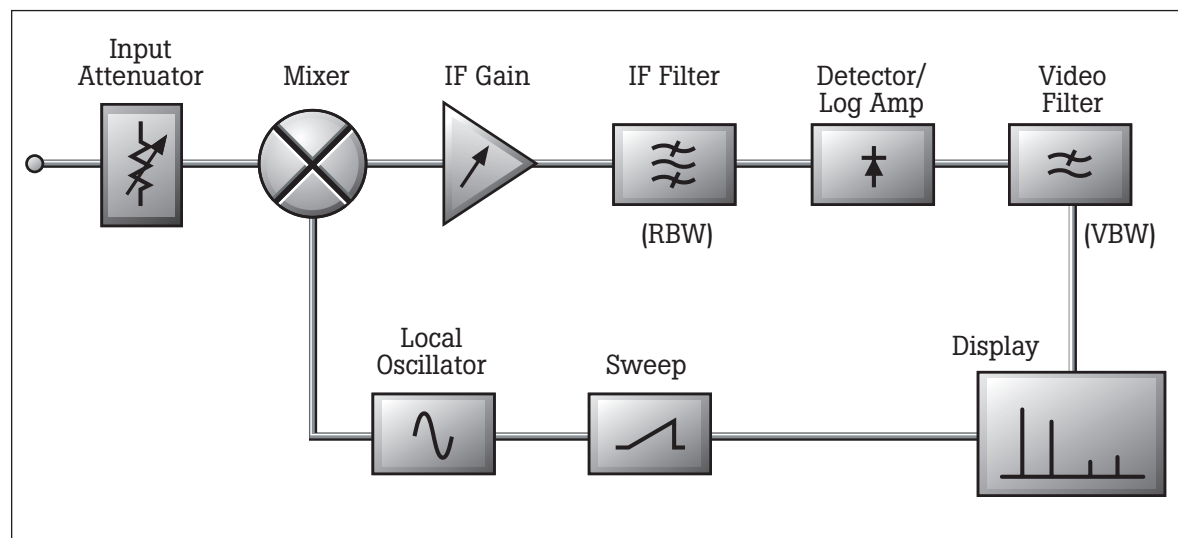

Figure 1. Architecture of a typical swept-tuned, superheterodyne spectrum analyzer.

### What does a spectrum analyzer measure?

A spectrum analyzer displays the frequency content of a signal, with the horizontal (X) axis indicating the signal frequency and the vertical (Y) axis the amplitude, as illustrated in Figure 2. In calibrating a spectrum analyzer, it's important to verify that the X axis, Y axis, and marker readout are all accurate.

#### X axis

The X axis measures the frequency of the signal. In the example shown in Figure 2, the X axis covers a span of 500 kHz, ranging from a start frequency of 499.75 MHz to a stop frequency of 500.25 MHz. The center point of the X axis is 500 MHz, and each division represents 50 kHz. The frequency of the horizontal axis is calibrated linearly, enabling you to measure and compare the frequency components of the signal.

#### Y axis

The Y axis enables you to measure either the relative amplitude of one signal against another or the absolute amplitude of a signal. In Figure 2, the top line of the display, representing 0 dBm, is set as the reference level, and the levels decrease as you move down the display, with each division representing a -10 dB step. Because it's possible that a signal's amplitude might be displayed accurately at one level and out of spec at another, it's important to verify the analyzer's accuracy and linearity throughout its amplitude range.

### Marker readout

The display also shows the marker readout, or cursor position. For spectrum analyzers with digital displays, differences between the cursor accuracy and display accuracy are less of a concern, as the displayed trace and the cursor readouts are produced from the same measurement data. But for older, analog instruments, it can be important to verify the accuracy of amplitude and frequency measurements for both the display and the cursor. In Figure 2, the amplitude of the cursor position is -9.91 dBm, and its frequency is 500 MHz.

### Settings

For most modern instruments, the display also shows the spectrum analyzer's settings. With newer spectrum analyzers, as you change the settings, the display scales and labels will change accordingly. The settings include:

- **RF attenuation.** This setting attenuates the input signal in order to avoid overloading the mixer. Otherwise, unwanted harmonic and intermodulation signals may appear in the displayed spectrum. In Figure 2, the RF attenuation is 30 dB.
- **Reference level.** This setting alters the IF gain to obtain the desired display. Whatever signal level you set as the reference level will be displayed at the top of the graticule. In Figure 2, the reference level is 0 dBm.

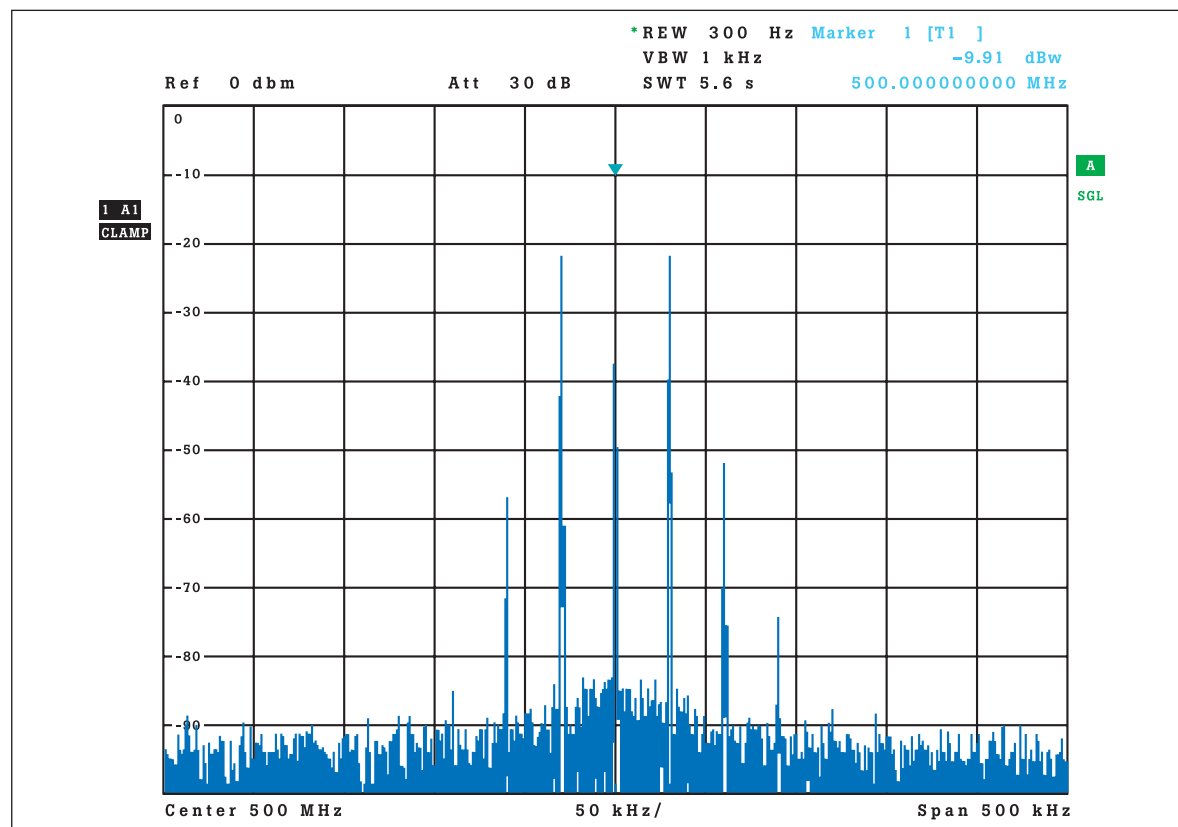

Figure 2. Understanding the display of a spectrum analyzer.

- **Resolution bandwidth.** This setting (abbreviated as RBW) refers to the bandwidth of the IF filter. The smaller the filter bandwidth, the longer time it takes to complete a sweep of a signal. In Figure 2, the filter bandwidth is 300 Hz.
- **Video bandwidth.** This setting (often abbreviated as VBW) determines how much the signal is filtered to remove noise after passing through the detector. The smaller the video bandwidth, the smoother the signal. In Figure 2, the video bandwidth is set to 1 kHz.
- **Sweep time.** The sweep time determines how long it takes to go from the start frequency to the stop frequency. In Figure 2, the sweep time is 5.6 seconds.

Note that the sweep time, filter bandwidth, and frequency span are all linked, in that a faster sweep time requires a wider filter bandwidth and/or a narrower span. If you speed up the sweep time without making the appropriate adjustments to the filter bandwidth and span, you could end up with a skewed and therefore false spectrum display. With newer analyzers, you set the span, filter bandwidth, and video bandwidth, and the analyzer automatically sets the appropriate sweep time. With older devices, you may have to manually adjust each setting to optimize the displayed signal of interest.

### Which calibration tests are needed?

While not all tests are required by all spectrum analyzer manufacturers, the following parameters represent a core set of the most frequently used tests for spectrum analyzer calibration

- Display Linearity
- Noise Floor
- Input Attenuator
- Absolute Amplitude Accuracy and Frequency Response
- Resolution Bandwidth and Selectivity
- Resolution Bandwidth Switching
- Reference Level Accuracy
- Noise Sidebands
- Residual FM
- Frequency Span Accuracy
- Sweep Time Accuracy
- Harmonic Distortion
- Third-Order Intermodulation Intercept
- Gain Compression

Although outside the scope of this application note, additional functional tests may include:

- Reference Output Accuracy
- Input Return Loss (VSWR)
- Marker Count Accuracy
- Filter Bandwidth Accuracy
- IF Gain Uncertainty
- Frequency Counter Readout Accuracy

Calibrating all of these parameters is not as daunting a task as it may seem, as it is possible to calibrate several of the core parameters with a single test equipment configuration. In fact, for many of the tests, the only equipment required is a signal generator and precision step attenuators. For the Frequency Response test, you also need a power meter and power splitters, and for the Noise Sidebands and Residual FM tests, you need to add a low phase noise signal generator.

Note that some of the tests that are outside the scope of this application note also require additional test equipment. For example, to perform the Reference Output Accuracy test, in addition to the basic test equipment you would need a universal counter and power meter.

For further information on either the core tests or the additional functional tests, see the reference documentation listed at the end of this application note.

The remainder of this document is devoted to describing several of the most common core tests. The top part of each diagram shows the part of the spectrum analyzer that is being tested, followed by an example of what you might see on the display; followed by the typical setup with traditional test equipment.

As you review the following test descriptions, be aware that the sequence in which the tests are performed is important, as some tests rely on the analyzer performance verified in previous tests. For example, calibration of the display linearity and noise floor usually needs to take place before most of the other tests. Because different manufacturers require different sets of tests, it's not possible to list a single test sequence that will work in all cases, so be sure to check your user handbook to determine the proper test sequence for your spectrum analyzer.

### Display Linearity test

This test, illustrated in Figure 3, calibrates the detector/log amplifier, video filter, and display components of the spectrum analyzer. Using fixed input attenuator and reference level settings, it verifies the machine's amplitude linearity over a wide dynamic range. Unlike many of the other tests, this test requires a signal source with high-precision attenuation linearity as a reference standard. Or, if your signal generator isn't calibrated for attenuation linearity, you can use a fixed output level setting and add external precision step attenuators as a reference standard, provided that the external attenuators have either been previously calibrated in a separate procedure or sent to another cal lab for certification. Additional attenuator pads are included, typically 3dB, to improve the match seen by the calibrated step attenuators and reduce mismatch uncertainties.

This test generally requires the signal source to be set at a fixed frequency and amplitude (typically 50 MHz @ +10 dBm), with both step attenuators set to 0 dB. You may need to adjust the signal generator to get the analyzer marker amplitude to read 0 dBm. Once you have the amplitude set to 0 dBm, it becomes your reference point and the signal generator must remain untouched for the remainder of the test.

The verification tables in the spectrum analyzer user handbook will instruct you to increase the attenuator setting one step at a time, recording the marker delta at each setting. For these readings to be accurate, you must use the actual attenuation values, as opposed to the nominal values. The formula for calculating the display linearity is:

$$\text{Display Linearity} = \text{Total Actual Attenuation} - \text{Cumulative Marker Delta reading}$$

In other words, setting a 10 dB attenuation may mean an actual attenuation value of 9.998 dB.

Important factors influencing the measurement uncertainty of the display linearity test include:

- Accuracy of the reference step attenuators.
- Mismatch error at the input and output of step attenuators
- Display resolution of the spectrum analyzer
- Signal-to-noise ratio of the measurement

The use of automated calibration software, however, can greatly simplify the task of calculating the measurement uncertainty.

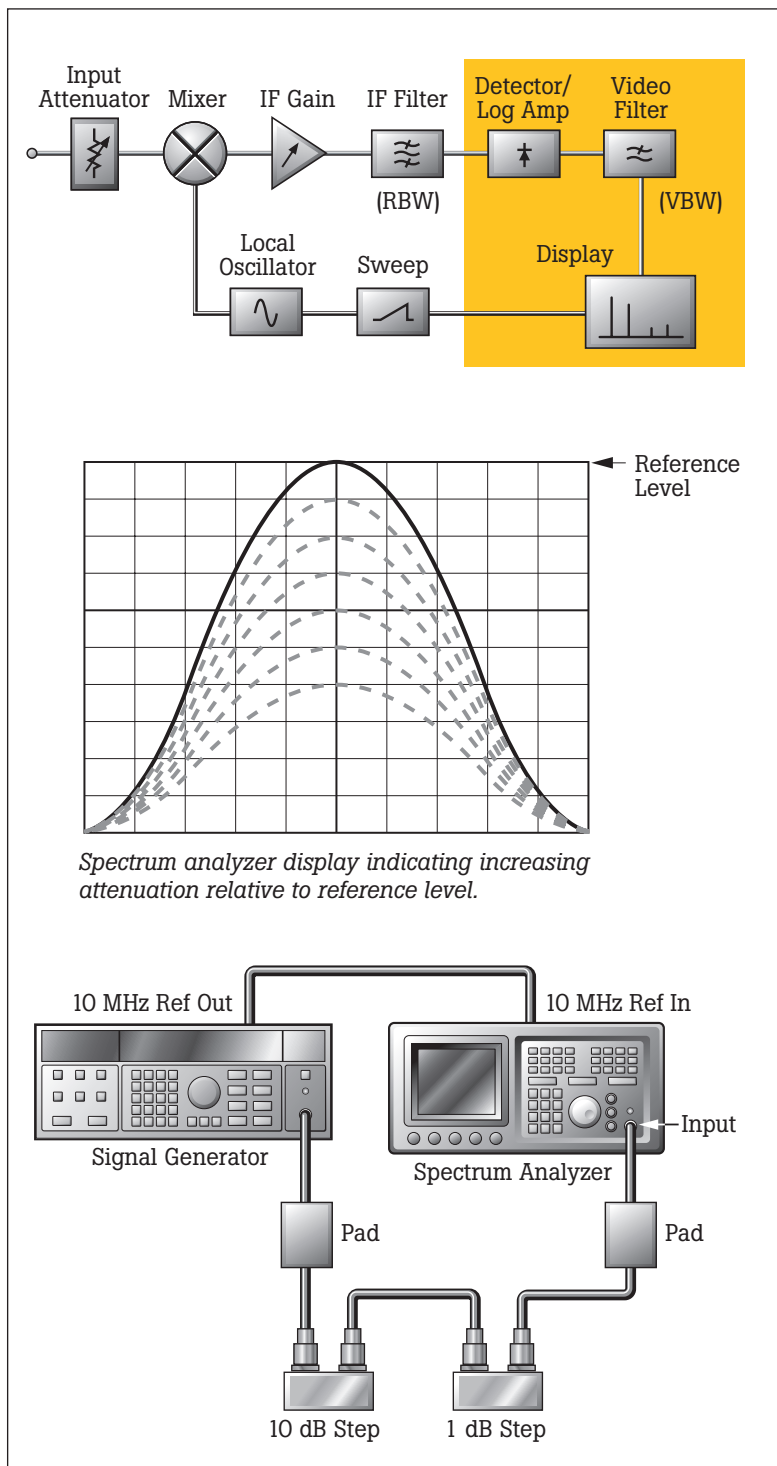

Figure 3. Display linearity test and typical traditional equipment setup

### Noise Floor test

The noise floor or displayed average noise level (DANL) has considerable bearing on the spectrum analyzer's ability to measure low-level signals. For this test, illustrated in Figure 4, you will need to apply a passive 50 Ω terminator to the spectrum analyzer's input.

To determine the displayed mean noise level (PM), you need first to calibrate the spectrum analyzer's display linearity and reference level accuracy. Then, with the 50 Ω terminator connected, place the display marker at the noise level and read the value ( $A_R$ ) in dBm. The displayed mean noise level is usually normalized to a 1 Hz or 10 Hz bandwidth, although it is not necessarily measured in a 1 Hz bandwidth.

$$P_M = P_R + A_R \text{ in dBm}$$

$P_R$  = set reference level

$A_R$  difference between the mean noise level and  $P_R$

You will need to perform this test for each of the resolution and video bandwidth settings specified by the manufacturer.

Important factors influencing the measurement uncertainty of the noise floor test include:

- Resolution of the spectrum analyzer display.
- Display linearity of the spectrum analyzer (as determined by a previous test)

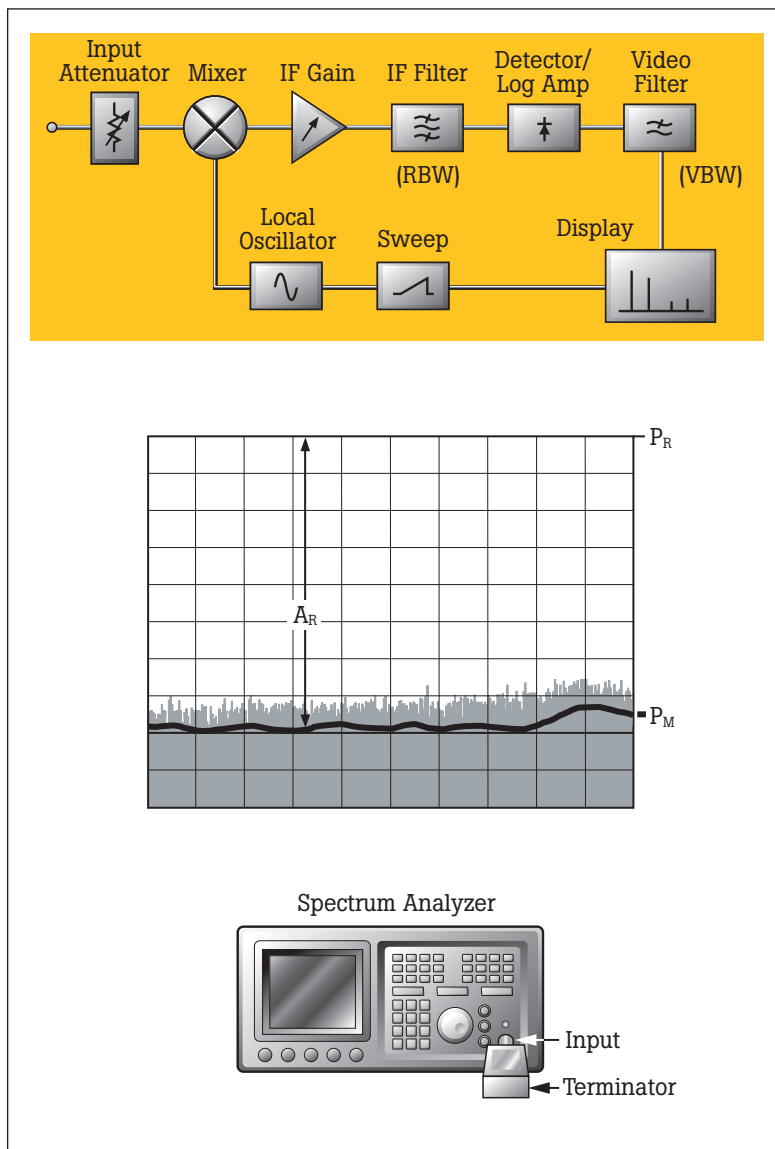

Figure 4. Noise Floor test and typical traditional equipment setup

### Input Attenuator test

This test calibrates the attenuator circuits of the spectrum analyzer. Accuracy of the stepped attenuation of the input signal is important because it affects the accuracy of signal level measurements. Figure 5 shows the test setup for the input attenuator test.

To perform this test, connect the test equipment as shown in Figure 5, using a reference signal that passes through calibrated step attenuators. Additional attenuator pads are included, typically 3dB, to improve the match seen by the calibrated step attenuators and reduce mismatch uncertainties. As you increase the external step attenuation, decrease the analyzer's input attenuation in accordance with the manufacturer's recommendations. At each attenuation step, record the delta level (MKR) shown on the display and compare it against the manufacturer's specifications to determine whether the spectrum analyzer passed or failed the test.

The actual attenuation provided by the nominal value of the reference step attenuators, from the calibration report ( $ATT_{EXTACTUAL}$ ), is being compared to the nominal attenuation provided by the spectrum analyzer's attenuator ( $ATT_{NOM}$ ). Knowing the actual value of each step of the reference attenuator, the difference from nominal can be computed. This difference must be subtracted from the delta-amplitude (MKR) indicated by the spectrum analyzer display in order to know how much the analyzer's attenuator step differs from nominal. The spectrum analyzer's attenuator accuracy (ACC) is given by:

$$ACC = [ ATT_{NOM} - ATT_{EXTACTUAL} ] - MKR$$

Important factors influencing the measurement uncertainty of the input attenuator test include:

- The accuracy of the external reference step attenuators
- Mismatch at the input and output of the step attenuator
- Display resolution of the spectrum analyzer (as read off the analyzer's display for each test)
- Display linearity of the spectrum analyzer (as determined by a previous test)
- Signal-to-noise ratio of the measurement (depends on the displayed mean noise level)

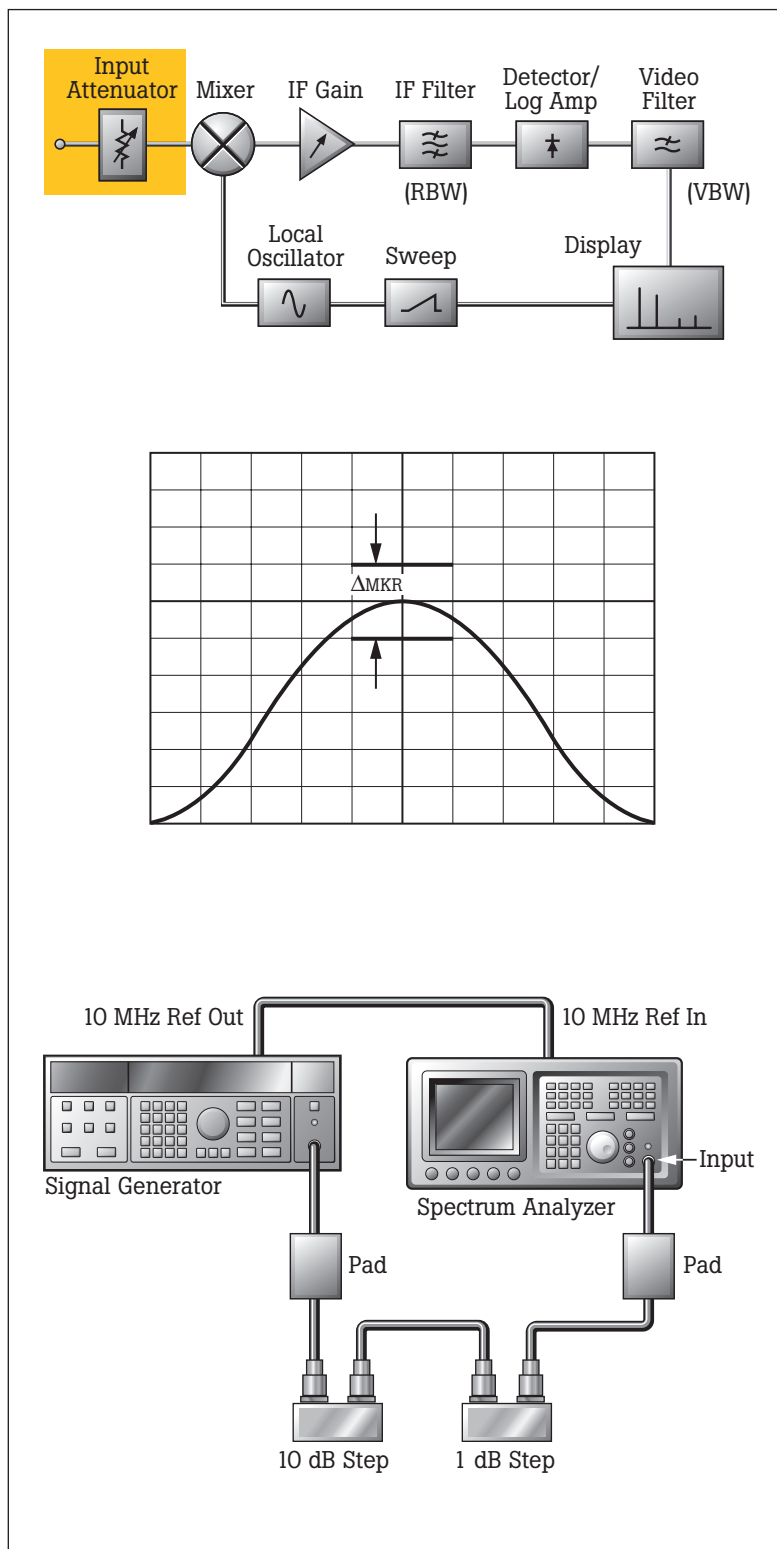

Figure 5. Input attenuator test and typical traditional equipment setup

### Absolute Amplitude Accuracy and Frequency Response test

The frequency response test, which calibrates the attenuator and mixer components of the spectrum analyzer, measures the amplitude error of the analyzer as a function of frequency. This test, illustrated in Figure 6, verifies the analyzer's amplitude response at a fixed level over its entire frequency range, relative to its response at a reference frequency (typically 50 MHz). The absolute amplitude accuracy test also calibrates the IF circuits to determine the analyzer's absolute level accuracy at the reference frequency. This test requires the addition of a power meter and power sensors as calibration standards.

To make the measurements, you feed the output of a signal generator through a power splitter to a power sensor, and then to the analyzer. But to improve amplitude accuracy, you start by calibrating the power splitter, which is done by connecting one power sensor (the "reference" sensor) to one power splitter output port. The other power splitter output port connects to a second "buried" sensor that is not removed from the power splitter. With this configuration, you measure and record the difference between the reference sensor and the buried sensor at each of the frequency points required by the analyzer manufacturer (typically, between 25 and 40 measurement points).

Once you have calibrated all the specified frequency points, you remove the reference sensor and replace it with the analyzer, again measuring each of the specified frequency points. At each point, you apply the power splitter calibration data to the result to remove any residual error generated by the power splitter.

Important factors influencing the measurement uncertainty of the frequency response test include:

- Frequency response of the reference power sensor
- Mismatch between the power splitter and the power sensor and between the power splitter and the spectrum analyzer
- Resolution of the spectrum analyzer display
- Display linearity of the spectrum analyzer (as determined by a previous test)
- Harmonic content of the signal generator output

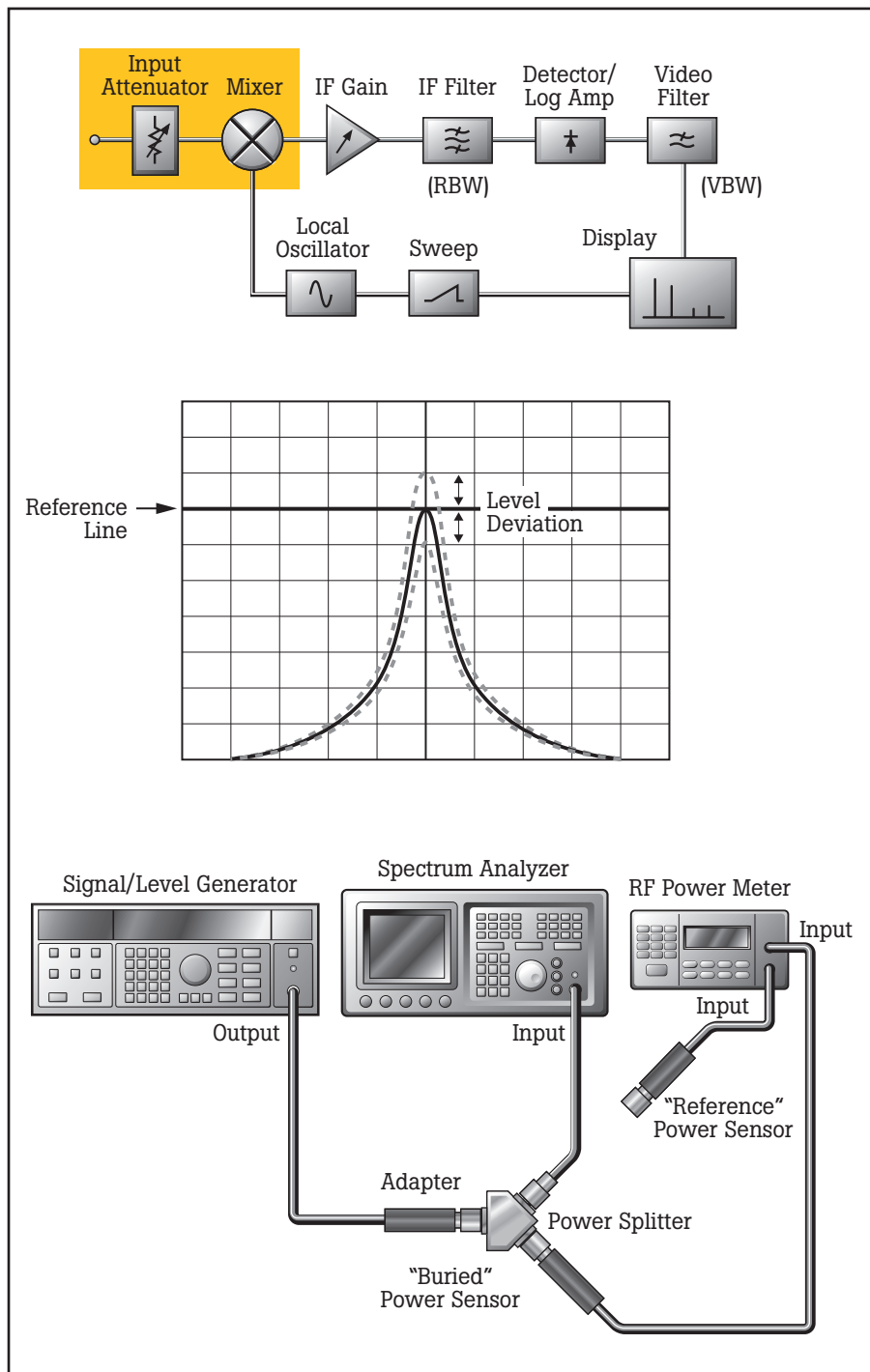

Figure 6. Frequency Response test and typical traditional equipment setup



### Resolution Bandwidth and Selectivity test

This test, illustrated in Figure 7, calibrates the bandwidth and bandwidth selectivity of the spectrum analyzer's individual IF filters. Bandwidth selectivity (also called shape factor) measures the ability of the analyzer to resolve closely spaced signals of unequal amplitude. It is specified as the ratio of the 60 dB bandwidth to the 3 dB bandwidth. It's important to have this parameter properly calibrated because if you select the wrong filter bandwidth or the shape of the filter skirt is in error, you will have difficulty differentiating between two signals of differing magnitude that are close in frequency.

To perform this test, you start by connecting the output of a signal generator to the input of the analyzer. Next, set the analyzer to the first filter bandwidth specified by the manufacturer, set the scaling to 1 dB/div, and determine the 3 dB bandwidth, as illustrated in Figure 7a. Then select

the manufacturer specified span per division setting and set the amplitude scale to 10 dB/div, expanding the signal so that it fills the entire display area. Read and record the 60 dB bandwidth as illustrated in Figure 7b. Repeat these measurements for each of the remaining filter bandwidth settings specified by the manufacturer. Now, calculate the bandwidth selectivity as follows (where "f" specifies the frequency):

$$\text{Bandwidth selectivity} = f_{60\text{dB}}/f_{3\text{dB}}$$

Important factors influencing the uncertainty of the filter bandwidth test measurement include:

- Frequency span/delta-marker accuracy of the spectrum analyzer
- The uncertainty of the span per division, as specified by the manufacturer
- Display linearity of the spectrum analyzer (as determined by a previous test)

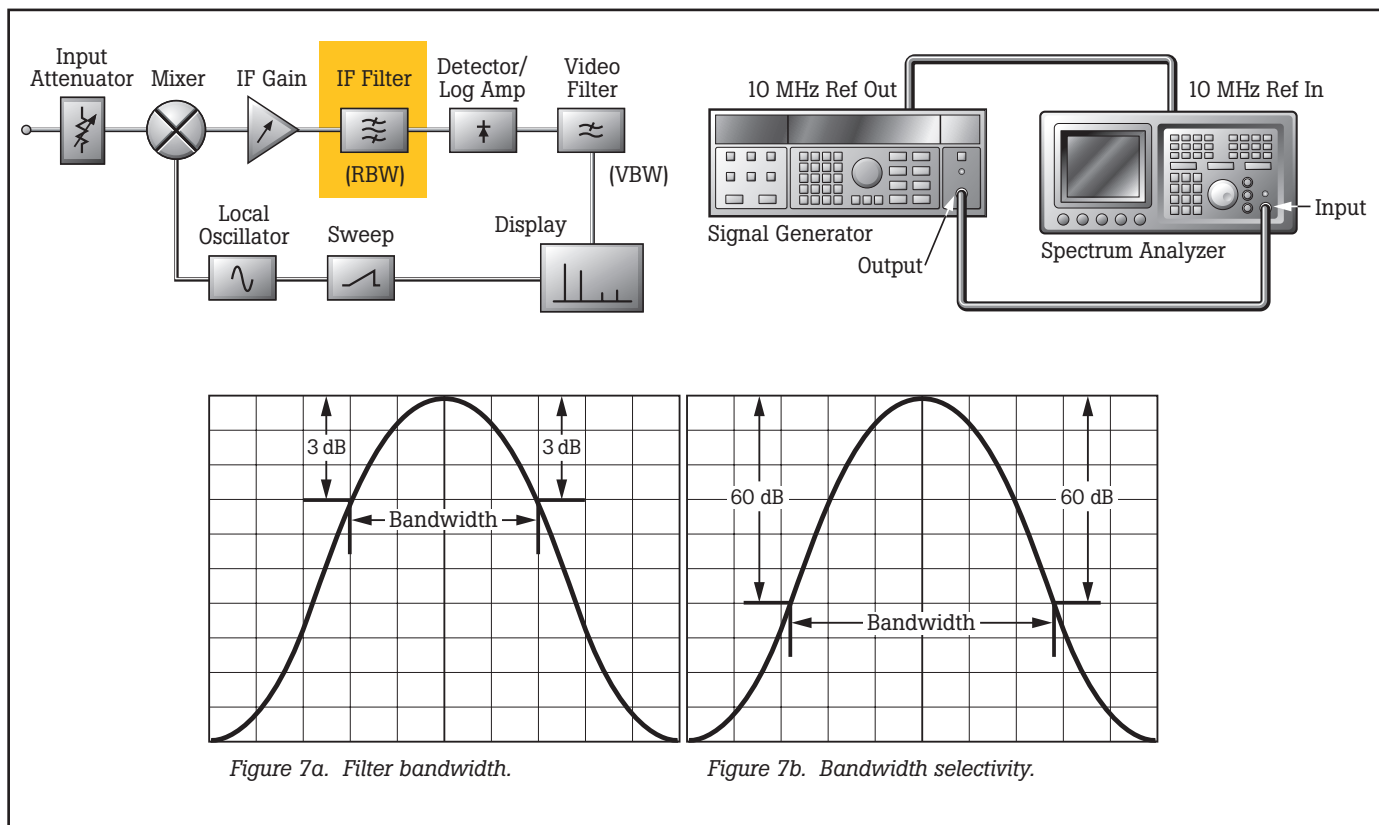

Figure 7. Resolution Filter Bandwidth and Selectivity test and typical traditional equipment setup

### Resolution Bandwidth Switching test

This test, shown in Figure 8, calibrates the gain and filter circuits of the spectrum analyzer and verifies that the filter gain remains constant for different filter bandwidth and span settings. The test uses a single input frequency, usually between 50 and 100 MHz.

Typically, the first step is to establish a 50 MHz reference level, using the reference marker on the spectrum analyzer display at a specific filter bandwidth and span setting (as specified by the spectrum analyzer manufacturer). Then adjust the spectrum analyzer for different filter bandwidth and span settings (again, as specified by the spectrum analyzer manufacturer), reading the delta marker for each

setting and determining the error by comparing the results with the spectrum analyzer's specifications.

The two traces in Figure 8 represent changes in the spectrum analyzer's filter bandwidth and span-per-division settings. If the IF gain did not change as the filter bandwidth and span settings were changed, the amplitude of the peaks of the curves would coincide. In most cases, however, they will not exactly coincide, so you will need to note the delta on the calibration report.

Important factors influencing the uncertainty of the filter bandwidth switching test include:

- Display linearity of the spectrum analyzer (as determined by a previous test)
- Resolution of the spectrum analyzer display

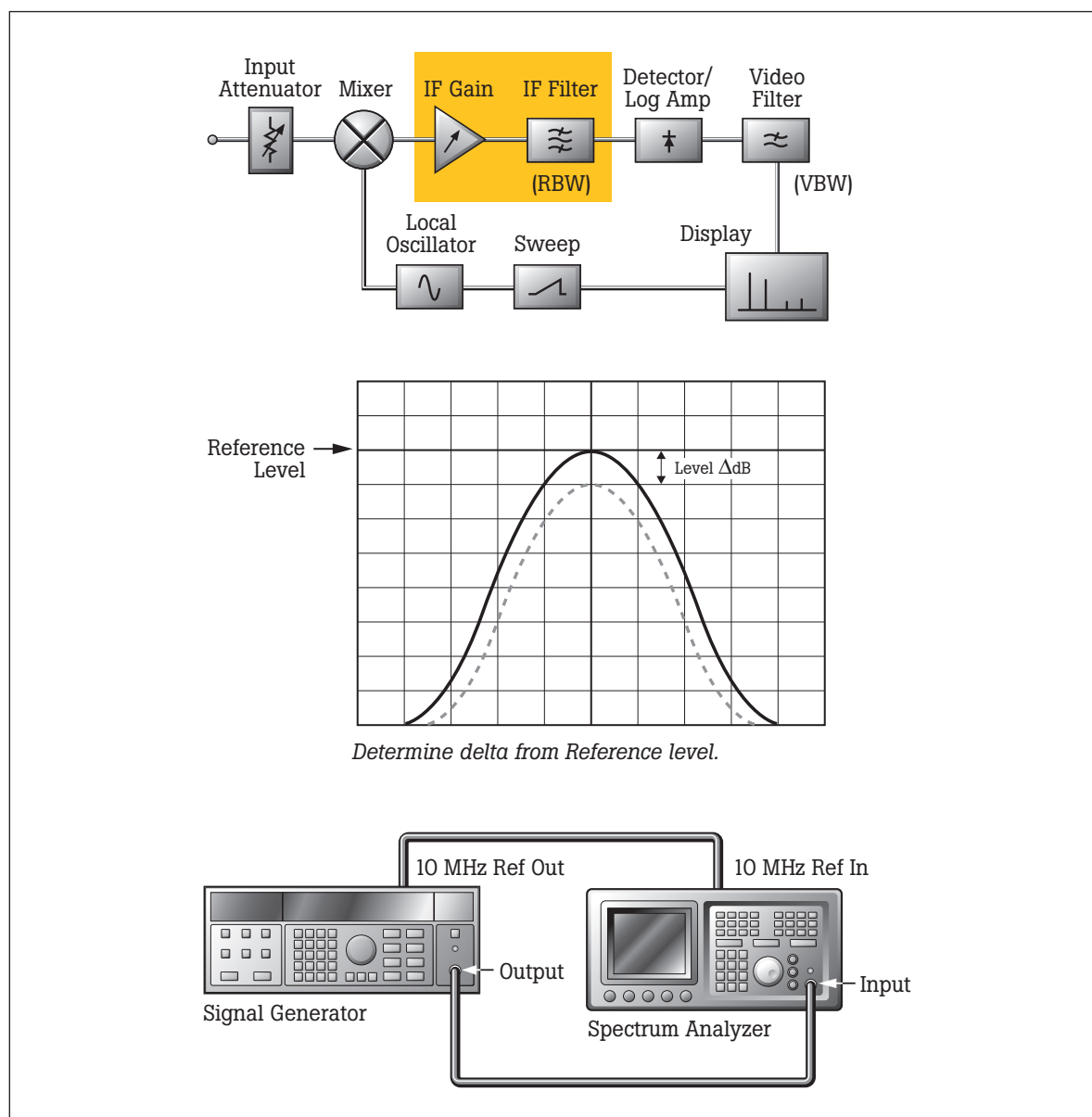

Figure 8. Resolution Bandwidth Switching test and typical traditional equipment setup

### Reference Level Accuracy test

This test, illustrated in figure 9, calibrates the IF amplifier and gain switching circuits, and is usually performed at a single low frequency, such as 50MHz.

To perform this test, set the analyzer to a high reference level setting (such as +10 dBm, or as recommended by the manufacturer), set the step attenuator to 0 dB, and adjust the signal generator output to obtain a signal display coincident with the reference level. Next, set the analyzer reference level 10 dB lower and increase the step attenuator by 10 dB. Determine the level deviation between the signal display and the reference level line and

note the error. Continue reducing the reference level setting and increasing the step attenuator setting for the required number of reference level settings, according to the manufacturer's recommendations.

Important factors influencing the uncertainty of the reference level accuracy test include:

- Accuracy of the step attenuators
- Mismatch error between the signal generator and the load
- Resolution of the spectrum analyzer display

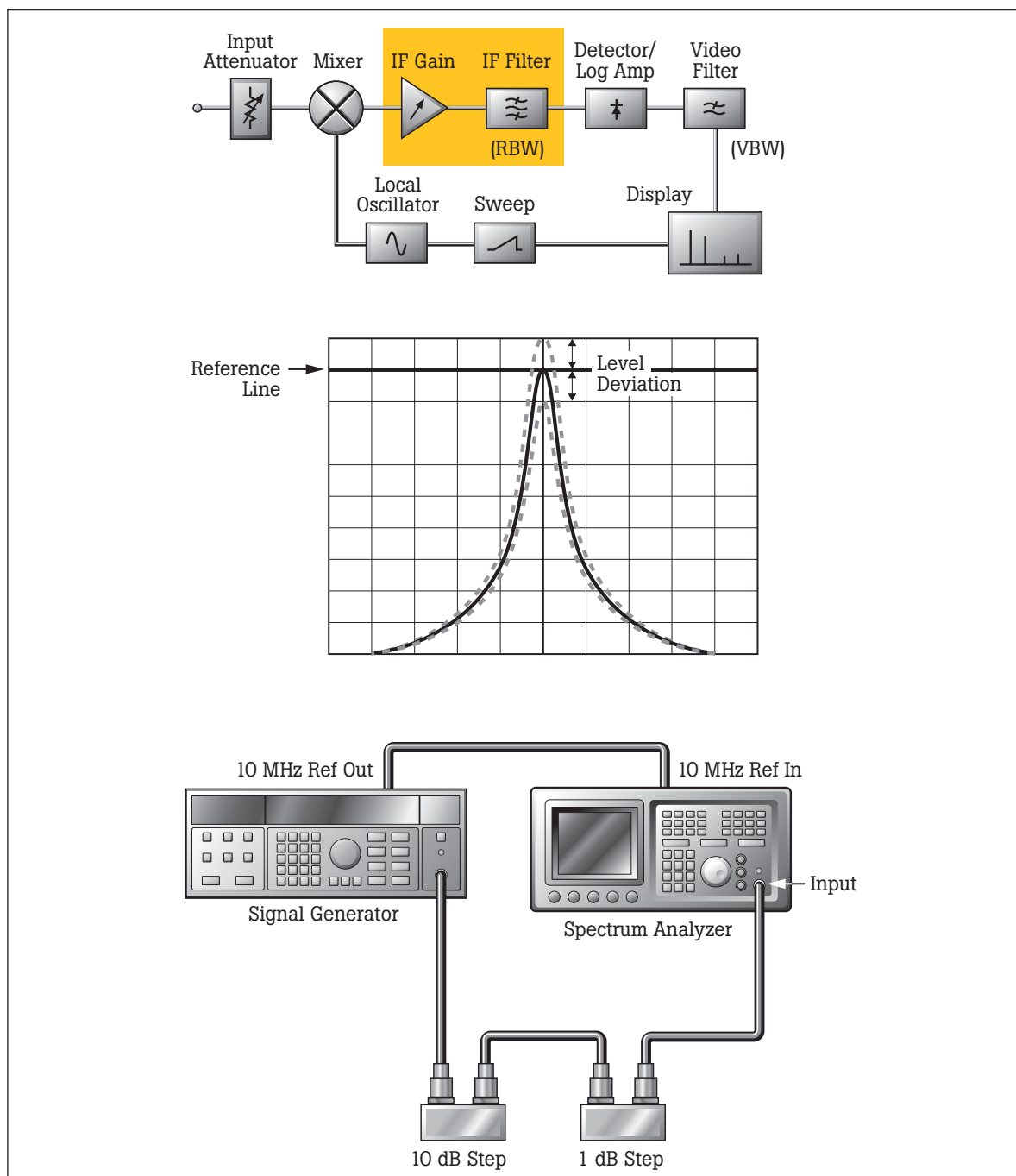

Figure 9. Reference Level Accuracy test and typical traditional equipment setup

### Noise Sideband test

This test, illustrated in Figure 10, verifies that the noise sidebands—that is, noise levels at frequency offsets above and below the carrier signal—drop off rapidly enough to fall within the specified limits for that particular spectrum analyzer. The test is performed at a single input frequency, as specified by the spectrum analyzer manufacturer. It's important to ensure that the signal generator used in this test is known to have low phase noise; otherwise, if the unit fails the test, there's no way to know if the failure is due to a problem with the spectrum analyzer or a problem with the source signal.

The noise sideband test results can be stated either in dBc, which shows the noise sideband level relative to the carrier signal for the given

bandwidth conditions, or dBc/Hz, which shows the sideband noise level normalized to a rectangular 1 Hz bandwidth.

Important factors influencing the uncertainty of the noise sideband test measurements include:

- Display linearity of the spectrum analyzer (as determined by a previous test)
- Resolution of the spectrum analyzer display
- Amplitude modulation noise of the spectrum analyzer
- Uncertainty of the RBW filter 3 dB bandwidth
- Amplitude modulation noise of the signal generator
- Noise sidebands of the signal generator

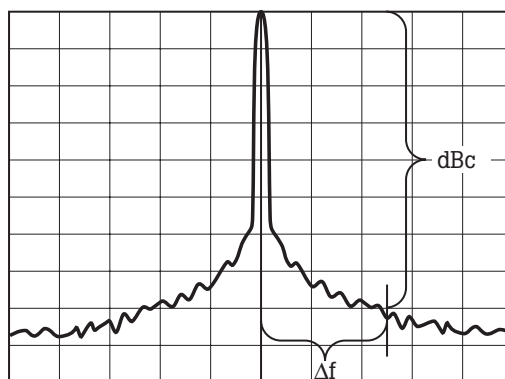
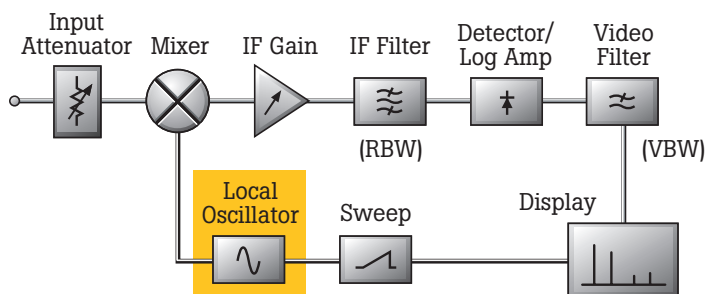

Noise level measurement at frequency offsets ( $\Delta f$ ) above the carrier .

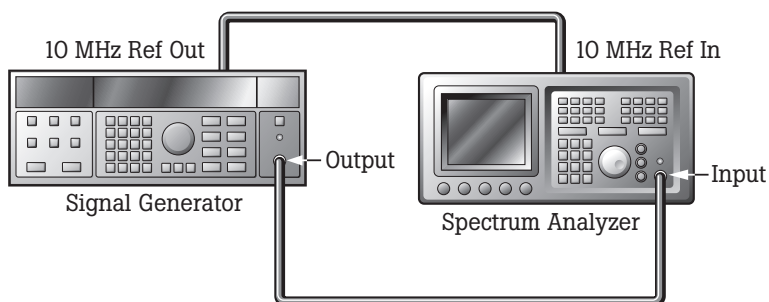

Figure 10. Noise Sideband test and typical traditional equipment setup

### Residual FM test

This test, shown in Figure 11, measures the residual FM caused by inherent short-term instability of the analyzer's local oscillator system, by using the linear part of the analyzer's IF filter response as an FM demodulator. The test first determines the slope of the IF filter (demodulation sensitivity) in Hz/dB and then measures the signal amplitude variation caused by the residual FM. Multiplying these two values yields the residual FM in Hz. Note that the equipment setup for this test is the same as that for the noise sideband test.

To determine the demodulation sensitivity, set both the spectrum analyzer center frequency and the signal generator output frequency to the value specified by the manufacturer (typically 1 GHz). Now set the span per division, filter bandwidth, and video filter to the manufacturer-specified values. Next, adjust the displayed signal so that the linear portion of the displayed response coincides with the center frequency, as shown in Figure 11, and note the marker-delta readout. Calculate the demodulation sensitivity (D), dividing the displayed marker delta frequency in Hz by the marker delta amplitude in dB, and record the result. For example, if the marker-delta frequency is 250 Hz and the marker delta amplitude is 4 dB, the demodulation sensitivity would be 62.5 Hz/dB.

Having calculated the demodulation sensitivity, your next step is to determine the peak-to-peak frequency deviation. With the analyzer set to zero span, use the fine adjustment on the center frequency to bring the zero span line into the display range. Then determine the peak-to-peak deviation in dB, using the spectrum analyzer's peak-to-peak search function.

Now you can determine the residual FM by multiplying the demodulation sensitivity (Hz/dB) by the peak-to-peak deviation (dB). Perform this calculation for each of the filter bandwidth settings specified in the spectrum analyzer user handbook, recording the result each time. Change only the filter bandwidth settings; all other settings (center frequency, span per division, and video bandwidth) are to remain fixed.

Important factors influencing the uncertainty of the residual FM test include:

- Display linearity of the spectrum analyzer (as determined by a previous test)
- Resolution of the spectrum analyzer display
- The residual FM of the signal generator
- Uncertainty of the frequency span as tested
- Nonlinearity of the IF filter response

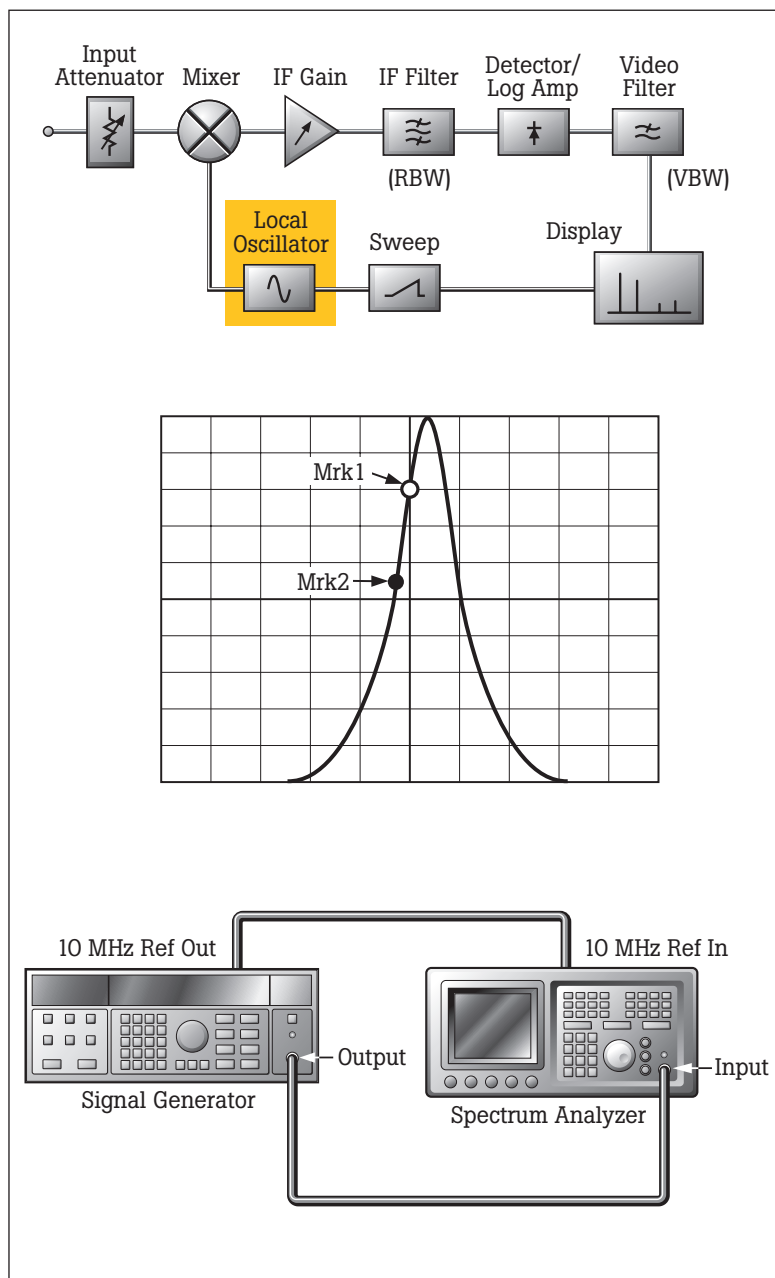

Figure 11. Residual FM test and typical traditional equipment setup

**Frequency Span test**

The frequency span test determines the accuracy of the analyzer’s frequency span, and can also test the linearity of the analyzer display’s frequency axis.

Begin this test by aligning the synthesizer frequency to the first vertical graticule on the display. Next, increase the synthesizer frequency by a factor of four times the value of the span/division setting, and then increase it again by a factor of eight. Now use the marker function to determine the deviation

from each graticule and compare the deviation to the manufacturer’s specification for span accuracy. Repeat this test for each of the span/division settings specified by the manufacturer.

Important factors influencing the uncertainty of the frequency span test include:

- Resolution of the spectrum analyzer display and maker readout
- Frequency accuracy of the synthesizer

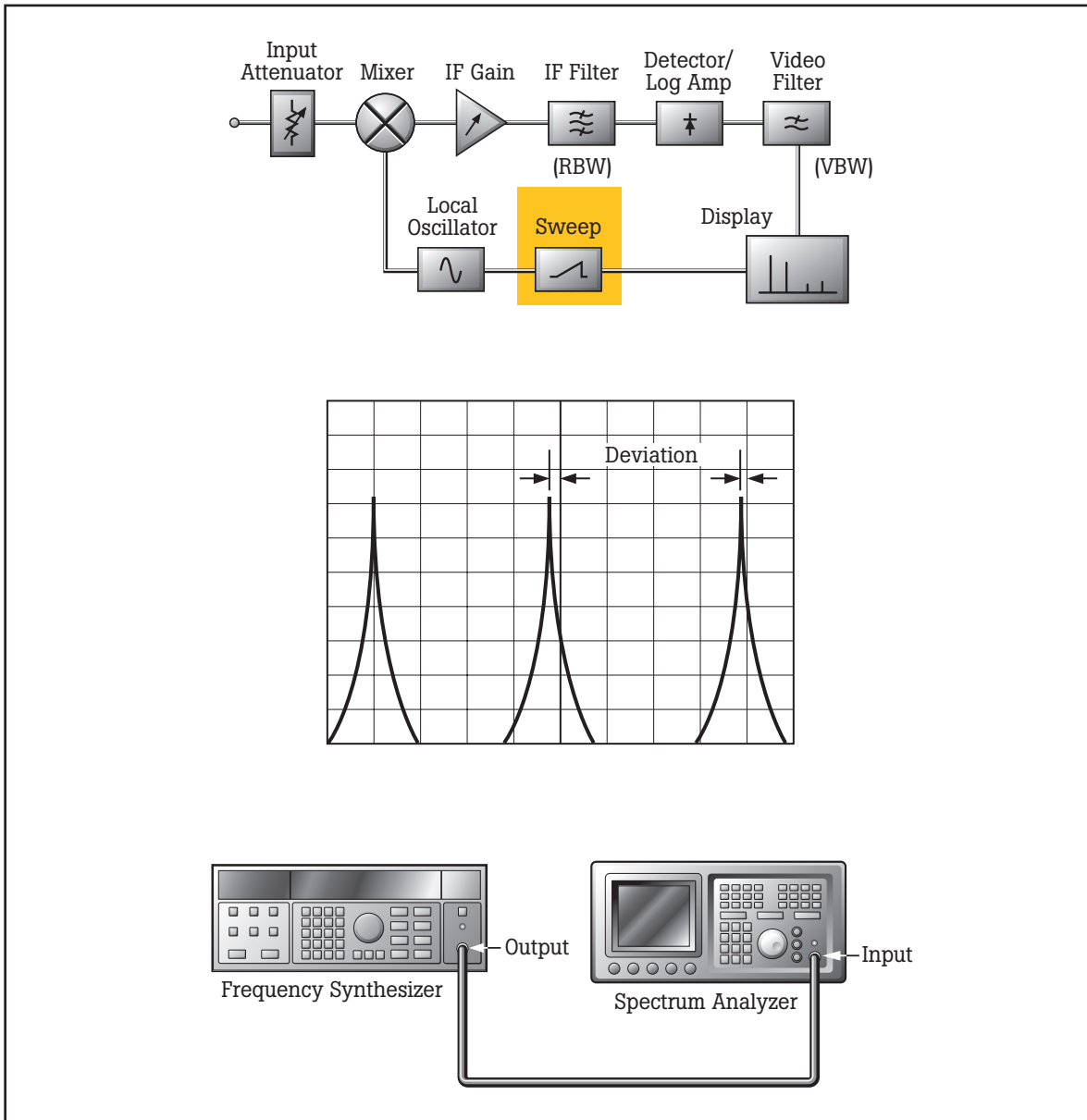

Figure 12. Frequency Span test and typical traditional equipment setup

### Sweep Time Accuracy test

To test the sweep time accuracy, connect the spectrum analyzer to the signal generator as shown in figure 13. Set the signal generator to output 50 % depth amplitude modulation, using an audio signal from an external function generator. The spectrum analyzer is set to zero-span mode starting with the shortest sweep time (e.g., 1 ms) to display the demodulated signal. Determine a suitable reference point on the spectrum analyzer's first vertical graticule line. Adjust the frequency of the function generator until a second reference point is established on the last vertical line of the display. At this

point, read off the frequency (f) from the function generator and calculate sweep time as:

$$\text{Sweep Time} = \left[ \frac{1}{f_{FG}} \right] \cdot (\text{number of cycles of waveform})$$

Record the sweep time and repeat the test for each spectrum analyzer sweep times specified by the manufacturer.

Important factors influencing the uncertainty of the sweep time accuracy test include:

- Resolution of the spectrum analyzer display
- Frequency accuracy of the function generator

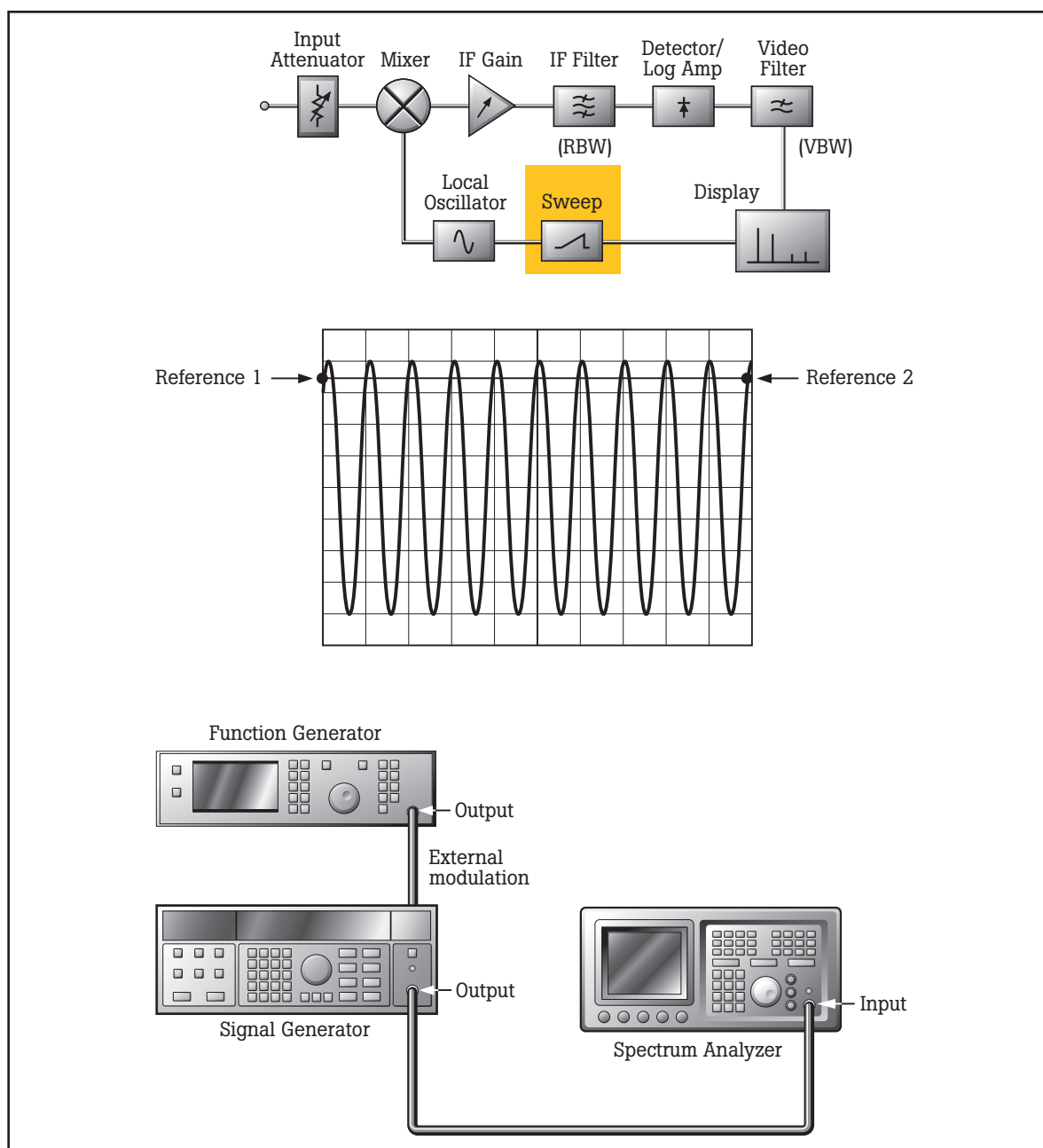

Figure 13. Sweep time accuracy test and typical traditional equipment setup

**Harmonic Distortion test**

This test verifies that any unwanted harmonic distortion generated within the analyzer is within the specified limits. Connect the analyzer to a signal generator, as shown in figure 14. A filter is used to avoid any harmonic content due to the signal generator adversely influencing the measured harmonic levels. The amount of unwanted harmonic content generated is dependent on the signal level at the mixer. Follow manufacturer’s recommendation for analyzer settings, test frequencies and signal levels.

Now adjust the signal generator output level to obtain a signal display which coincides with the

required reference level with the analyzer center frequency set to the signal input frequency ( $f_1$ ). Set the analyzer center frequency to the required harmonic frequency ( $f_2$ ) and record the displayed harmonic level ( $H_1$ ).

Important factors influencing the uncertainty of the harmonic distortion test include:

- Harmonic content of the test signal
- Uncertainty of the reference level
- Display linearity of the spectrum analyzer (as determined by a previous test)
- Resolution of the spectrum analyzer display
- Signal-to-noise ratio

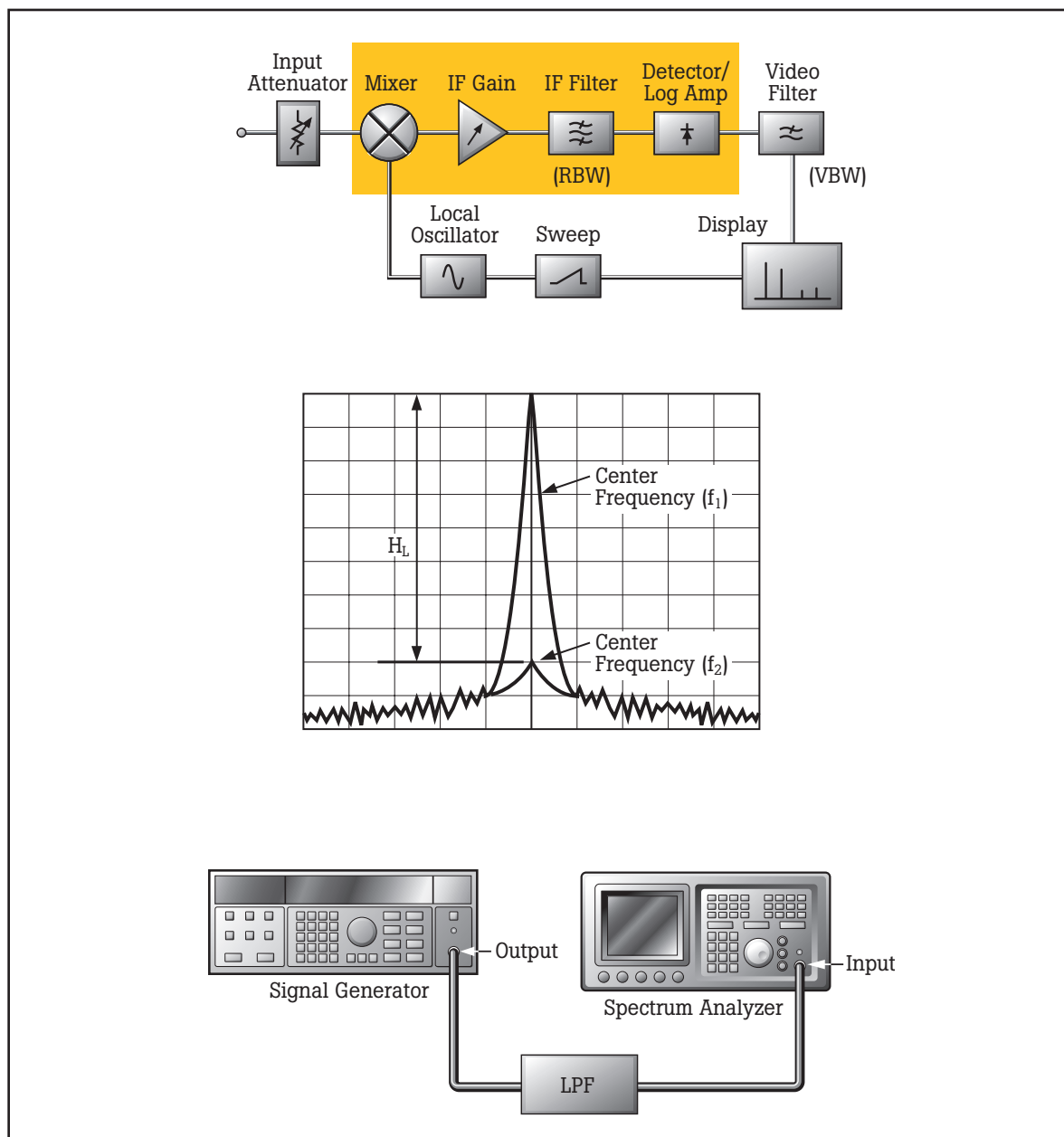

Fig 14. Harmonic Distortion test and typical traditional equipment setup



### Third-Order Intermodulation Intercept test

If two signals are present simultaneously at the spectrum analyzer input, the input mixer will generate unwanted intermodulation. The amount of intermodulation will depend on the signal level at the mixer (mixer level). The amount of intermodulation produced is described by the Intermodulation Intercept figure, which represents the mixer level required to produce intermodulation products equal to the input signal level. This signal level is beyond the working range of the analyzer and cannot be measured directly, but you can calculate it for any input level. Together with the results of the noise floor test, the intermodulation intercept test will determine the dynamic range of the spectrum analyzer which is normally expressed as a ratio of the largest to the smallest signal applied simultaneously at the input of the spectrum analyzer.

The test requires two signals applied to the spectrum analyzer input. Configure the spectrum analyzer settings as specified by the manufacturer. Generally, you should set the OdB input attenuator so that the mixer level is equal to the analyzer input level. Now set the first signal generator to the spectrum analyzer center frequency ( $f_1$ ) and set the second signal generator to the offset from the center frequency ( $f_2$ ) specified by the manufacturer. Set the amplitude level for both  $f_1$  and  $f_2$  to the same value ( $R_L$ , in dBm). Measure the intermodulation products at  $2f_2 - f_1$  and  $2f_1 - f_2$  with respect to  $R_L$ . Record the smaller of the two levels ( $I_{R3}$ ).

Calculate the third order intermodulation intercept (TOI) as shown below, (assuming the input attenuator setting is OdB):

$$TOI = R_L + \left[ \frac{I_{R3}}{2} \right]$$

Repeat tests for all measurement frequencies as specified by the manufacturer covering the frequency range of the spectrum analyzer.

Important factors influencing the uncertainty of the third-order intermodulation intercept test include:

- Resolution of the spectrum analyzer display
- Display linearity of the spectrum analyzer (as determined by a previous test)
- Uncertainty of the reference level
- Intermodulation rejection of the signal generators combined with the power coupler

### Gain Compression test

This test determines how well the spectrum analyzer can measure low amplitude signals in the presence of high amplitude signals. Gain compression is measured using two signals separated in frequency and at different amplitudes (see Figure 16). The test procedure defined in the manufacturer's calibration handbook will specify the level and amplitude of each signal at specific frequencies. The lower signal level will usually be at least 35dB below the higher signal level to avoid contributing significant additional power.

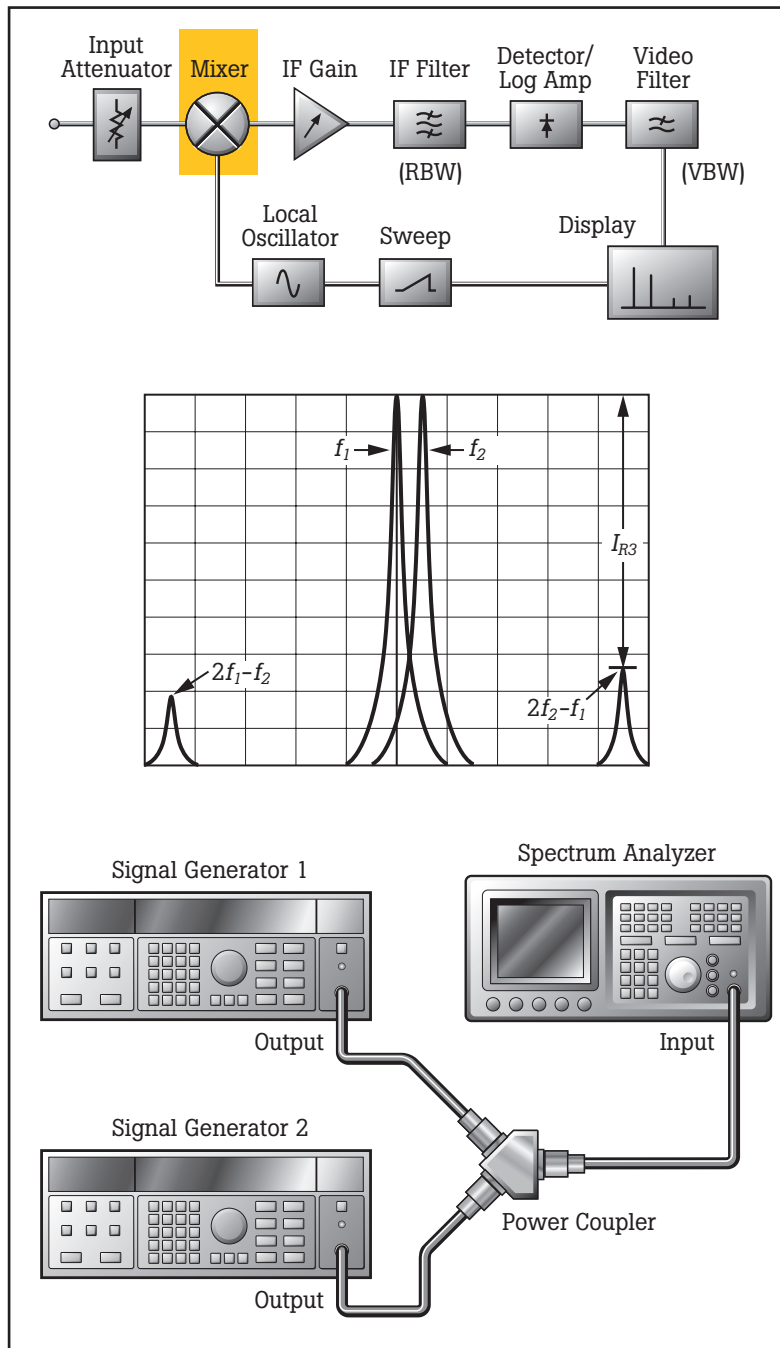

Figure 15. Third Order Intermodulation Intercept test and typical traditional equipment setup

This test will require two signal generators, a power meter to level each source and a coupler to introduce both signals simultaneous to the spectrum analyzer input.

The resultant gain compression is determined from a two step process. First measure ( $m_1$ ) the displayed amplitude of the lower level ( $f_2$ ) signal with the higher amplitude signal switched off, uncompressed. Secondly, switch on the higher level ( $f_1$ ) signal and again measure ( $m_2$ ) the displayed lower amplitude, compressed. The difference between the uncompressed and compressed

measurements is the resultant gain compression and is compared with the spectrum analyzer Gain Compression specifications.

Important factors influencing the uncertainty of the gain compression test include:

- Resolution of the spectrum analyzer display
- Display linearity of the spectrum analyzer (as determined by a previous test)
- Uncertainty of the reference level

### Complexity reduction and automation

Spectrum analyzer calibration is recognized as one of the more difficult, time consuming and error prone tasks in a calibration lab. The consumer's cost of having these devices calibrated in a commercial cal lab directly reflects the arduous, time consuming and exacting nature of these calibrations.

In this application note we have explained the multiple steps and connection setups typically required during the calibration and the calculations necessary to obtain the results. A traditional spectrum analyzer calibration system contains many individual instruments and devices; including several low and high frequency signal generators, power meters, filters, fixed and step attenuators, splitters, adapters and RF cabling. These devices need to be connected and disconnected multiple times during a calibration.

A typical high-performance spectrum analyzer model calibration involves over 27 separate test setups. At each connection transition there exists the very real possibility that correction factors for the specific power sensor, filter, splitter or adapter, etc., may be interpreted and applied incorrectly by the operator, necessitating the test be subsequently repeated to obtain valid results. Excessive mismatches, or even connector damage, often can be created by improper torqueing of the connectors, further complicating results. These are some of the factors mentioned throughout this article that influence the measurement uncertainty of the calibration.

Depending on the spectrum analyzer model and the tests required by its manufacturer's calibration procedure, a manual spectrum analyzer calibration can take from 8 to over 20 hours of constant operator time to accomplish. One of the more time consuming elements of calibration can be in calculating losses in the multitude of connections that must be made; another is interpreting and integrating manufacturers' uncertainty specifications at different instrument settings and input/output conditions.

Automated calibration software can greatly reduce calibration times. Automating a system can relieve the operator from continually changing instrument settings during a specific test. While automation can save significant time over manual methods, automating the traditional calibration process using individual standards mentioned above still requires a multitude of interconnections and cabling setups during the calibration, adding opportunities for operator error.

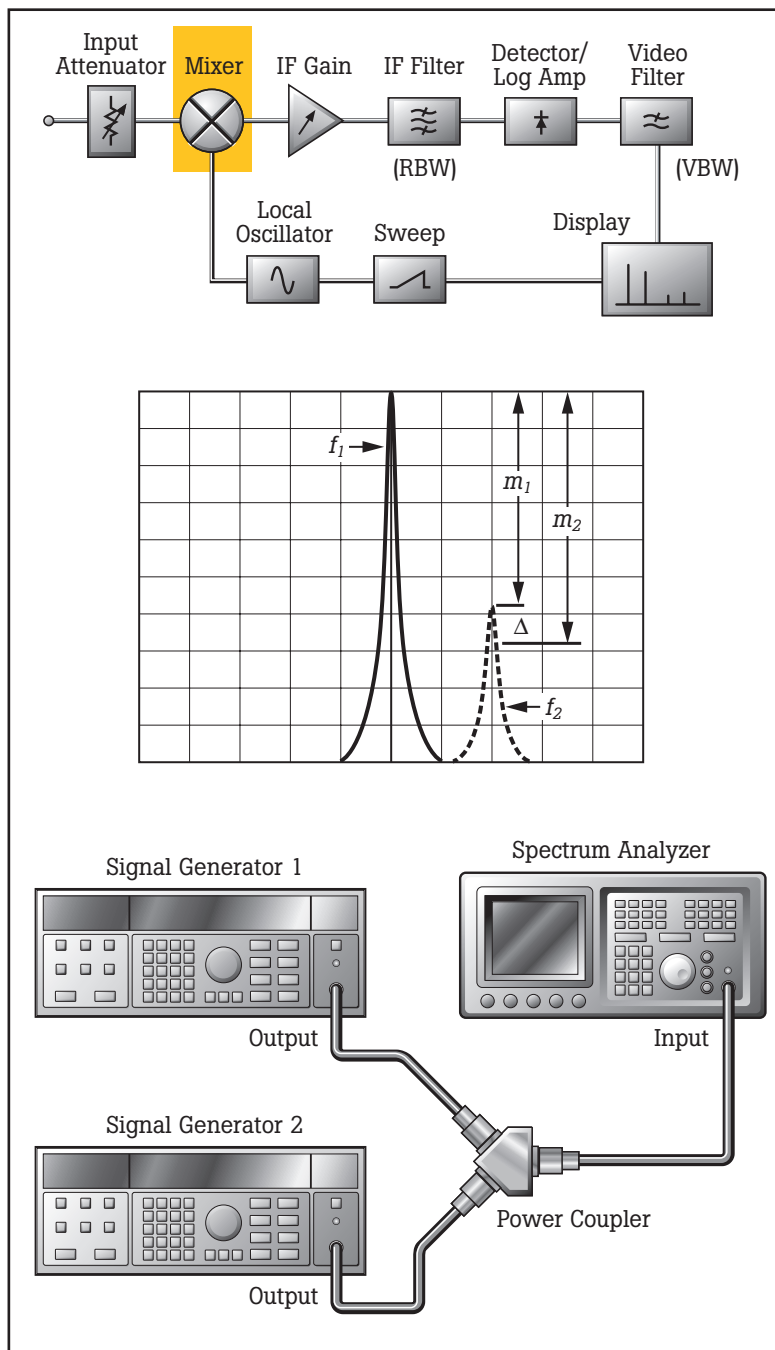

Figure 16. Gain Compression test and typical traditional equipment setup

One family of RF reference sources—the Fluke Calibration 96000 Series—is purpose built with calibration-oriented features for the RF calibration lab. The design of these specialized RF reference sources eliminates the need for multiple individual instruments and devices typically found in a traditional system. These RF reference sources are capable of calibrating up to 80 % of all spectrum analyzers on the market today without any additional equipment.

In replicating functionality of these traditional system components in one specialized RF calibration instrument comes the benefit of a large reduction of connection changes required during a spectrum analyzer calibration. A typical high performance spectrum analyzer model requires only four separate setups, representing an 85 % complexity reduction, applicable to manual or automated calibrations.

These advanced RF reference sources automatically characterize all system devices and interconnections for losses and automatically apply compensation to deliver the exact signal level dialed in on the instrument front panel directly at the UUT input, thus eliminating the need for manually calculated correction factors or adjusting instrument settings. When these specialized RF calibration instruments are complemented with automated calibration software calibration time can be reduced to as little as one hour and ten minutes for a typical high-end spectrum analyzer. For almost an hour the system runs without operator intervention, allowing the operator to “walk away” and attend to other tasks. Compared to traditional automation, system operator efficiency typically improves by 60 %, system capacity by 25 %.

Calibration labs currently having a high workload of spectrum analyzers or those considering performing spectrum analyzer calibration will derive long term benefits from automated software coupled with these specialized RF reference sources as mentioned here.

**Conclusion**

We began this application note by stating that spectrum analyzer calibration is perceived as complex and time consuming. This is true for those who are not familiar with the task, or who perform the tests manually. However, with careful selection of individual reference standards or a specialized RF calibration source as mentioned here, and automated calibration software, the task of producing a calibration report is well within reach of most calibration labs. By calibrating your spectrum analyzer at the intervals specified by the manufacturer, you can ensure that its measurements are accurate and that the electronic equipment that you test with it will perform within specification.

**References**

Keysight (formerly Agilent Technologies) Application Note 150, “Spectrum Analysis Basics”

VDI/VDE/DGQ/DKD 2622, “Calibration of measuring equipment for electrical quantities: Spectrum Analyzer.”

**Fluke Calibration.** *Precision, performance, confidence.™*

Electrical	RF	Temperature	Pressure	Flow	Software
------------	----	-------------	----------	------	----------

**Fluke Calibration**  
 PO Box 9090, Everett, WA 98206 U.S.A.  
**Fluke Europe B.V.**  
 PO Box 1186, 5602 BD  
 Eindhoven, The Netherlands

**For more information call:**  
 In the U.S.A. (877) 355-3225 or  
 Fax (425) 446-5116  
 In Europe/M-East/Africa +31 (0) 40  
 2675 200 or Fax +31 (0) 40 2675 222  
 In Canada (800)-36-FLUKE or  
 Fax (905) 890-6866

From other countries +1 (425) 446-5500 or  
 Fax +1 (425) 446-5116  
 Web access: <http://www.flukecal.com>

©2006-2015 Fluke Calibration.  
 Specifications subject to change without notice.  
 Printed in U.S.A. 10/2015 2519570d-en  
 Pub\_ID 11048 eng. Rev 04

**Modification of this document is not permitted without written permission from Fluke Calibration.**