

4200-SCS

Semiconductor Characterization System



4200-SPEC Rev. H



S J ELECTRONICS
POWER • TEST & MEASUREMENT

0800 583 44 55

Tel: +44 1536 416 200

Fax: 0800 583 55 66

sales@sjelectronics.co.uk

www.sjelectronics.co.uk

1.888.KEITHLEY (U.S. only)

www.keithley.com

KEITHLEY

A GREATER MEASURE OF CONFIDENCE

Model 4200-SCS technical data

SEMICONDUCTOR

4200-SCS

Semiconductor Characterization System

- 2 Introduction
- 3 Configuration Options
- 5 Hardware Specifications
- 14 KTE Interactive Software Tools
 - 14 Microsoft Windows
 - 15 The Keithley Interactive Test Environment (KITE)
 - 22 Keithley User Library Tool (KULT)
 - 23 System Configuration and Diagnostics (KCON)
 - 23 Keithley External Control Interface (KXCI)
- 24 Support Contracts
- 25 Value-Add Services
- 25 Upgrades
- 26 Warranty Information
- 26 Embedded PC Policy
- 26 Switch Matrix Support and Configurations
- 28 Optional Accessories

Introduction

The Model 4200-SCS provides a total system solution for DC I-V, C-V, and pulse characterization and stress-measure/reliability testing of semiconductor devices and test structures. This advanced parameter analyzer provides intuitive and sophisticated capabilities for semiconductor device characterization. The 4200-SCS combines unprecedented measurement speed and accuracy with an embedded Windows®-based PC and the Keithley Interactive Test Environment (KITE) to provide a powerful single-box solution.

The Keithley Interactive Test Environment allows users to gain familiarity quickly with tasks such as managing tests and results and generating reports. Sophisticated and simple test sequencing and external instrument drivers simplify performing automated device and wafer testing with combined I-V and C-V measurements. Our new integrated capacitance-voltage measurement unit, the Model 4200-CVU, makes C-V measurements as easy as DC measurements.

The 4200-SCS is modular and configurable. The system supports up to eight Source-Measure Units, including up to eight high power SMUs with 1A/20W capability. An optional Remote PreAmp extends the resolution of any Source-Measure Unit from 100fA to 0.1fA.

KTEI (Ver. 7.0) provides software support for DC SMUs and a number of new instruments. Besides the C-V measurement unit described previously, it supports a dual-channel pulse generator card (the Model 4205-PG2) that plugs into one of the Model 4200-SCS's slots, just like an SMU, and a choice of dual-channel digital oscilloscopes for time- and voltage-domain measurements. Together, the pulse generator and oscilloscope make it simple and cost-effective to integrate pulsing, waveform generation, and signal observation capabilities into the Model 4200-SCS's test environment.

Our KTEI software (Ver. 7.0) supports three test application packages to expand the Model 4200-SCS's pulsed testing capabilities: 4200-PIV-A performs charge trapping and isothermal testing for leading-edge CMOS research; 4200-PIV-Q tests for higher power pulse in III-V, LDMOS, and other higher frequency FET devices; and 4200-FLASH tests FLASH embedded memory devices.

1.888.KEITHLEY (U.S. only)

www.keithley.com

KEITHLEY

A GREATER MEASURE OF CONFIDENCE

Configuration Options

The 4200-SCS supports many instrument configurations that can include SMUs, C-V measurement units, pulse generators, and oscilloscopes. The standard configuration includes two medium power Source-Measure Units (SMUs) and a Ground Unit.

Standard 4200-SCS Models

4200-SCS/F	Chassis 12.1" flat panel display Two (2) Model 4200-SMU medium power SMUs One (1) Remote Sense Ground Unit LAN, GPIB, USB, RS-232, parallel port, hard disk, CD-RW
4200-SCS/C	Chassis Composite Front Bezel (i.e., no built-in display) Two (2) Model 4200-SMU medium power SMUs One (1) Remote Sense Ground Unit LAN, GPIB, USB, RS-232, parallel port, hard disk, CD-RW

Source-Measure Units

Each system can be configured with up to six additional SMUs, for a total of eight SMUs. Two SMU models are available: a medium power (100mA, 2W) version (Model 4200-SMU) and a high power (1A, 20W) version (Model 4210-SMU). The system can support up to eight high power SMUs.

4200-SCS Source-Measure Units

	MAXIMUM VOLTAGE	MAXIMUM CURRENT	MAXIMUM POWER
4200-SMU (medium power)	210V	100mA	2W
4210-SMU (high power)	210V	1A	20W

Remote PreAmp

The low current measurement capabilities of any SMU can be extended by adding an optional Remote PreAmp (Model 4200-PA). The 4200-PA provides 0.1fA resolution by effectively adding five current ranges to either SMU model. The PreAmp module is fully integrated with the system; to the user, the SMU simply appears to have additional measurement resolution available. The Remote PreAmp is shipped installed on the back panel of the 4200-SCS for local operation. This installation allows for standard cabling to a prober, test fixture, or switch matrix. Users can remove the PreAmp from the back panel and place it in a remote location (such as in a light-tight enclosure or on the prober platen) to eliminate measurement problems due to long cables. Platen mounts and triax panel mount accessories are available. Remote PreAmps are installed at the factory in numerical order, i.e., SMU1, SMU2, SMU3... up to the number of PreAmps specified.

Capacitance-Voltage Instrument

C-V measurements are now as easy to perform as I-V measurements with the new integrated C-V instrument, the Model 4200-CVU. This optional capacitance-voltage instrument performs capacitance measurements from femtofarads (fF) to nanofarads (nF) at frequencies from 10kHz to 10MHz. It also supplies diagnostic tools that ensure the validity of your C-V test results.

With this system, you can configure linear or custom C-V, C-f and C-t sweeps with up to 4096 data points. In addition, through the open environment of the 4200-SCS, you can modify any of the included tests.

Pulse Generator

The Model 4205-PG2 Dual-Channel Pulse Generator provides dual-channel pulsing with voltage pulses as short as 10ns in high speed mode or up to $\pm 20V$ (into 50Ω) in high voltage mode. It supports two new waveform generation modes in addition to the standard pulse capability. The Arbitrary Waveform Mode can generate complex waveforms made up of up to 256K data points at clock speeds up to 25MHz. The Segment ARB™ Mode (patent-pending) generates waveforms made up of up to 1024 user-defined line segments. Each segment can have a different duration.

Oscilloscope

The system supports two dual-channel integrated digital oscilloscope options: the Model 4200-SCP2 offers 8-bit resolution with a sample rate up to 2.5 gigasamples/second, while the Model 4200-SCP2HR provides 16-bit resolution and a sample rate up to 400 megasamples/second. Both can be programmed for automated measurement and data acquisition or used with the stand-alone GUI application provided to perform traditional oscilloscope tasks. They provide measurements in both the time (frequency, rise/fall time) and voltage domains (amplitude, peak-peak, etc.).

Configuration Examples

The 4200-SCS's plug-in chassis design offers exceptional configuration flexibility, as the following examples illustrate. A chassis can contain up to eight SMUs in any combination of high and medium powered units. Any configuration can be specified without a flat panel display by substituting the 4200-SCS/C for the 4200-SCS/F. However, an external SVGA monitor is required to operate the 4200-SCS/C.

Maximum DC Configuration

Configuration:	One (1) Model 4200-SCS/F (includes two medium power SMUs as the standard configuration, which can be substituted with two high power SMUs) Six (6) additional Model 4210-SMUs (total of eight; all eight can be high power SMUs) Eight (8) Model 4200-PA Remote PreAmp modules
Description:	Provides an eight-SMU system with 0.1fA sensitivity on all eight SMUs and 1A capability on all eight channels.

Maximum Pulse Configuration

Configuration:	One (1) Model 4200-SCS/F Four (4) Model 4205-PG2 dual-channel pulse generators (8 channels) One (1) digital oscilloscope (Model 4200-SCP2 or 4200-SCP2HR) Three (3) Model 4200-SMUs Three (3) Model 4200-PA Remote PreAmp modules
Description:	Provides a three-SMU system with eight channels that support traditional pulse mode, arbitrary waveform mode (ARB), Segment ARB™ waveform mode (Segment ARB or SARB), and trigger-in. Each pulse channel contains an inline High Endurance Output Relay (solid-state relay). The oscilloscope provides pulse measure and waveform monitoring.

Example Broad Use Case Configuration

Configuration:	One (1) Model 4200-SCS/F Two (2) Model 4200-SMU medium power SMUs Two (2) Model 4210-SMU high power SMUs One (1) Model 4200-CVU capacitance-voltage measurement unit Two (2) Model 4205-PG2 pulse generators One (1) Model 4200-SCP2 digital oscilloscope
Description:	Provides a four-SMU system that supports a wide range of DC I-V, C-V, and pulse testing capability.

Hardware Specifications DC SMU Hardware Specifications

CURRENT SPECIFICATIONS

	CURRENT RANGE ¹		MEASURE		SOURCE	
		MAX. VOLTAGE	RESOLUTION ³	ACCURACY ±(% rdg + amps)	RESOLUTION ³	ACCURACY ±(% rdg + amps)
4210-SMU ²	1 A	21 V	1 μA	0.100% + 200 μA	50 μA	0.100% + 350 μA
	100 mA	210 V	100 nA	0.045% + 3 μA	5 μA	0.050% + 15 μA
4200-SMU ² High Power SMU	100 mA	21 V	100 nA	0.045% + 3 μA	5 μA	0.050% + 15 μA
	10 mA	210 V	10 nA	0.037% + 300 nA	500 nA	0.042% + 1.5 μA
	1 mA	210 V	1 nA	0.035% + 30 nA	50 nA	0.040% + 150 nA
	100 μA	210 V	100 pA	0.033% + 3 nA	5 nA	0.038% + 15 nA
	10 μA	210 V	10 pA	0.050% + 600 pA	500 pA	0.060% + 1.5 nA
	1 μA	210 V	1 pA	0.050% + 100 pA	50 pA	0.060% + 200 pA
4200-SMU and 4210-SMU with optional 4200-PA PreAmp	100 nA	210 V	100 fA	0.050% + 30 pA	5 pA	0.060% + 30 pA
	1 nA	210 V	3 fA	0.050% + 100 fA	50 fA	0.060% + 300 fA
	100 pA	210 V	1 fA	0.100% + 30 fA	15 fA	0.100% + 80 fA
	10 pA	210 V	0.3 fA	0.500% + 15 fA	5 fA	0.500% + 50 fA
	1 pA	210 V	100 aA	1.000% + 10 fA	1.5 fA	1.000% + 40 fA

VOLTAGE COMPLIANCE: Bipolar limits set with a single value between full scale and 10% of selected voltage range.

VOLTAGE SPECIFICATIONS

VOLTAGE RANGE ¹	MAX. CURRENT		MEASURE		SOURCE	
	4200-SMU	4210-SMU	Resolution ³	Accuracy ±(% rdg + volts)	Resolution ³	Accuracy ±(% rdg + volts)
200 V ⁺	10.5 mA	105 mA	200 μV	0.015% + 3 mV	5 mV	0.02% + 15 mV
20 V	105 mA	1.05 A	20 μV	0.01% + 1 mV	500 μV	0.02% + 1.5 mV
2 V	105 mA	1.05 A	2 μV	0.012% + 150 μV	50 μV	0.02% + 300 μV
200 mV	105 mA	1.05 A	1 μV	0.012% + 100 μV	5 μV	0.02% + 150 μV

CURRENT COMPLIANCE: Bipolar limits set with a single value between full scale and 10% of selected current range.

Supplemental Information

Supplemental information is not warranted but provides useful information about the Models 4200-SMU, 4210-SMU, and 4200-PA.

COMPLIANCE ACCURACY:

Voltage compliance equals the voltage source specifications.
Current compliance equals the current source specifications.

OVERSHOOT: <0.1% typical.

Voltage: Full scale step, resistive load, and 10mA range.
Current: 1mA step, $R_L = 10k\Omega$, 20V range.

RANGE CHANGE TRANSIENT:

Voltage Ranging: <200mV.
Current Ranging: <200mV.

ACCURACY SPECIFICATIONS: Accuracy specifications are multiplied by one of the following factors, depending upon the ambient temperature and humidity.

Temperature	% Relative Humidity	
	5–60	60–80
10°–18°C	×3	×3
18°–28°C	×1	×3
28°–40°C	×3	×5

REMOTE SENSE: <10Ω in series with FORCE terminal not to exceed a 5V difference between FORCE and SENSE terminals. ±30V maximum between COMMON and SENSE LO.

MAXIMUM LOAD CAPACITANCE: 10nF.

MAXIMUM GUARD OFFSET VOLTAGE: 3mV from FORCE.

GUARD OUTPUT IMPEDANCE: 100kΩ.

MAXIMUM GUARD CAPACITANCE: 1500pF.

MAXIMUM SHIELD CAPACITANCE: 3300pF.

4200-SMU and 4210-SMU SHUNT RESISTANCE (FORCE to COMMON): >10¹²Ω (100nA–1μA ranges).

4200-PA SHUNT RESISTANCE (FORCE to COMMON): >10¹⁶Ω (1pA and 10pA ranges), >10¹³Ω (100pA–100nA ranges).

OUTPUT TERMINAL CONNECTION: Dual triaxial connectors for 4200-PA, dual mini-triaxial connectors for 4200-SMU and 4210-SMU.

NOISE CHARACTERISTICS (typical):

Voltage Source (rms): 0.01% of output range.

Current Source (rms): 0.1% of output range.

Voltage Measure (p-p): 0.02% of measurement range.

Current Measure (p-p): 0.2% of measurement range.

MAXIMUM SLEW RATE: 0.2V/μs.

SPECIFICATION CONDITIONS

Specifications are the performance standards against which the Models 4200-SMU, 4210-SMU, and 4200-PA are tested. The measurement and source accuracy are specified at the termination of the supplied cables.

- 23°C ±5°C, within 1 year of calibration, RH between 5% and 60%, after 30 minutes of warm-up.
- Speed set to NORMAL.
- Guarded Kelvin connection.
- ±1°C and 24 hours from ACAL.

1.888.KEITHLEY (U.S. only)

www.keithley.com

KEITHLEY

A GREATER MEASURE OF CONFIDENCE

Additional DC SMU Specifications

MAX. OUTPUT POWER: 22 watts for 4210-SMU and 2.2 watts for 4200-SMU (both are four-quadrant source/sink operation).

DC FLOATING VOLTAGE: COMMON can be floated ± 32 volts from chassis ground.

VOLTAGE MONITOR (SMU in VMU mode):

Voltage Range	Measure Resolution	Measure Accuracy \pm (%rdg + volts)
200 V	200 μ V	0.015% + 3 mV
20 V	20 μ V	0.01% + 1 mV
2 V	2 μ V	0.012% + 110 μ V
200 mV	1 μ V	0.012% + 80 μ V

INPUT IMPEDANCE: $>10^{13}\Omega$.

INPUT LEAKAGE CURRENT: <30 pA.

MEASUREMENT NOISE: 0.02% of measurement range (rms).

DIFFERENTIAL VOLTAGE MONITOR:

Differential Voltage Monitor is available by measuring with two SMUs in VMU mode or by using the low sense terminal provided with each SMU.

GROUND UNIT

Voltage error when using the ground unit is included in the 4200-SMU, 4210-SMU, and 4200-PA specifications. No additional errors are introduced when using the ground unit.

OUTPUT TERMINAL CONNECTION: Dual triaxial, 5-way binding post.

MAXIMUM CURRENT: 2.6A using dual triaxial connection; 8.5A using 5-way binding posts.

LOAD CAPACITANCE: No limit.

CABLE RESISTANCE: FORCE $\leq 1\Omega$, SENSE $\leq 10\Omega$.

GENERAL**TEMPERATURE RANGE**

Operating: $+10^{\circ}$ to $+40^{\circ}$ C.

Storage: -15° to $+60^{\circ}$ C.

HUMIDITY RANGE

Operating: 5% to 80% RH, non-condensing.

Storage: 5% to 90% RH, non-condensing.

ALTITUDE

Operating: 0 to 2000m.

Storage: 0 to 4600m.

POWER REQUIREMENTS: 100V to 240V, 50 to 60Hz.

MAXIMUM VA: 500VA.

REGULATORY COMPLIANCE:

Safety: Low Voltage Directive 73/23/EEC.

EMC: Directive 89/336/EEC.

DIMENSIONS: 43.6cm wide \times 22.3cm high \times 56.5cm deep (17 $\frac{1}{2}$ in \times 8 $\frac{3}{4}$ in \times 22 $\frac{1}{4}$ in).

WEIGHT (approx.): 29.7kg (65.5 lbs) for typical configuration of four SMUs.

I/O PORTS: USB, SVGA, Printer, RS-232, GPIB, Ethernet, Mouse, Keyboard.

NOTES

- All ranges extend to 105% of full scale.
- Specifications apply on these ranges with or without a 4200-PA.
- Specified resolution is limited by fundamental noise limits. Measured resolution is 6 $\frac{1}{2}$ digits on each range. Source resolution is 4 $\frac{1}{2}$ digits on each range.
- Interlock must be engaged to use the 200V range.



S J ELECTRONICS
POWER • TEST & MEASUREMENT

0800 583 44 55

Tel: +44 1536 416 200

Fax: 0800 583 55 66

sales@sjelectronics.co.uk

www.sjelectronics.co.uk

1.888.KEITHLEY (U.S. only)

www.keithley.com

KEITHLEY

A GREATER MEASURE OF CONFIDENCE

Model 4200-CVU Specifications

MEASUREMENT FUNCTIONS

MEASUREMENT PARAMETERS: Cp-G, Cp-D, Cs-Rs, Cs-D, R-jX, Z-theta.

RANGING: Auto and fixed.

MEASUREMENT TERMINAL CONFIGURATION:

Four-terminal pair.

CONNECTOR TYPE: Four SMA (female) connectors.

CABLE LENGTH: 0m, 1.5m, or 3m selectable.

INTEGRATION TIME: FAST, NORMAL, QUIET, and CUSTOM.

TEST SIGNAL

FREQUENCY RANGE: 10kHz to 10MHz.

MINIMUM RESOLUTION: 10kHz, 100kHz, 1MHz depending on frequency range.

SOURCE FREQUENCY ACCURACY: $\pm 0.1\%$.

SIGNAL OUTPUT LEVEL RANGE: 10mV rms to 100mV rms.

RESOLUTION: 1mV rms.

ACCURACY: $\pm(10.0\% + 1mV\ rms)$ unloaded (at rear panel).

OUTPUT IMPEDANCE: 100 Ω , typical.

DC BIAS FUNCTION

DC VOLTAGE BIAS:

Range: $\pm 30V$.

Resolution: 1.0mV.

Accuracy: $\pm(0.5\% + 5.0mV)$ unloaded.

MAXIMUM DC CURRENT: 10mA.

SWEEP CHARACTERISTICS

AVAILABLE SWEEP PARAMETERS: DC bias voltage, frequency.

SWEEP TYPE: Linear, custom.

SWEEP DIRECTION: Up sweep, down sweep.

NUMBER OF MEASUREMENT POINTS: 4096.

EXAMPLE OF INCLUDED LIBRARIES

- C-V, C-t, and C-f measurements and analysis of:
 - High and low κ structures
 - MOSFETs
 - BJTs
 - Diodes
 - III-V compound devices
 - Carbon nanotube (CNT) devices
- Doping profiles, T_{OX} , and carrier lifetime tests
- Junction, pin-to-pin, and interconnect capacitance measurements

The C-V instrument integrates directly into the Model 4200-SCS chassis. It can be purchased as an upgrade to existing systems or as an option for new systems.

MEASUREMENT ACCURACY

Example of C/G Measurement Accuracy

Frequency	Measured Capacitance	C Accuracy ¹	G Accuracy ^{1,2}
10 MHz ³	1 pF	$\pm 0.92\%$	$\pm 260\ ns$
	10 pF	$\pm 0.32\%$	$\pm 990\ ns$
	100 pF	$\pm 0.29\%$	$\pm 9\ \mu s$
1 MHz	1 nF	$\pm 0.35\%$	$\pm 99\ \mu s$
	1 pF	$\pm 0.38\%$	$\pm 42\ ns$
	10 pF	$\pm 0.16\%$	$\pm 65\ ns$
100 kHz	100 pF	$\pm 0.09\%$	$\pm 590\ ns$
	1 nF	$\pm 0.09\%$	$\pm 4\ \mu s$
	10 pF	$\pm 0.17\%$	$\pm 15\ ns$
10 kHz	100 pF	$\pm 0.18\%$	$\pm 59\ ns$
	1 nF	$\pm 0.08\%$	$\pm 450\ ns$
	10 nF	$\pm 0.08\%$	$\pm 3\ \mu s$
10 kHz	100 pF	$\pm 0.26\%$	$\pm 15\ ns$
	1 nF	$\pm 0.15\%$	$\pm 66\ ns$
	10 nF	$\pm 0.08\%$	$\pm 450\ ns$
10 kHz	10 nF	$\pm 0.08\%$	$\pm 450\ ns$
	100 nF	$\pm 0.08\%$	$\pm 3\ \mu s$

NOTES

1. The capacitance and conductance measurement accuracy is specified under the following conditions: $D_x < 0.1$.
2. Conductance accuracy is specified as the maximum conductance measured on the referenced capacitor.
3. These specs are typical. Typical and supplemental specs are non-warranted, apply at 23°C, and are provided solely as useful information.

Integration time: QUIET.
Test signal level: 30mV rms.
At the rear panel of the 4200-CVU.

SUPPLEMENTAL CABLE SPECIFICATION

4200-CVU Typical C Accuracy with 1.5m Cables (supplemental)

Measured Capacitance	10 kHz	100 kHz	1 MHz	10 MHz
1 pF	$\pm 8.38\%$	$\pm 1.95\%$	$\pm 0.43\%$	N/A
10 pF	$\pm 0.94\%$	$\pm 0.21\%$	$\pm 0.18\%$	$\pm 1\%$
100 pF	$\pm 0.29\%$	$\pm 0.2\%$	$\pm 0.15\%$	$\pm 1\%$
1 nF	$\pm 0.17\%$	$\pm 0.12\%$	$\pm 0.16\%$	$\pm 2\%$
10 nF	$\pm 0.12\%$	$\pm 0.13\%$	$\pm 0.25\%$	$\pm 2\%$
100 nF	$\pm 0.13\%$	$\pm 0.22\%$	$\pm 1.14\%$	N/A

4200-CVU Typical C Accuracy with 3m Cables (supplemental)

Measured Capacitance	10 kHz	100 kHz	1 MHz	10 MHz
1 pF	$\pm 8.5\%$	$\pm 2.05\%$	$\pm 0.57\%$	N/A
10 pF	$\pm 0.96\%$	$\pm 0.23\%$	$\pm 0.21\%$	$\pm 1\%$
100 pF	$\pm 0.29\%$	$\pm 0.2\%$	$\pm 0.17\%$	$\pm 1\%$
1 nF	$\pm 0.17\%$	$\pm 0.12\%$	$\pm 0.18\%$	$\pm 2\%$
10 nF	$\pm 0.12\%$	$\pm 0.13\%$	$\pm 0.27\%$	$\pm 2\%$
100 nF	$\pm 0.13\%$	$\pm 0.22\%$	$\pm 1.16\%$	N/A

CVU CONFIDENCE CHECK

The 4200-CVU includes a diagnostic tool called Confidence Check. It allows users to check the integrity of open and short connections and connections to a device-under test (DUT). When the Model 4200-CVU is connected to a DUT, Confidence Check displays the measured readings in real time. This also allows Confidence Check to be used as a C-V meter to perform quick and accurate measurements.

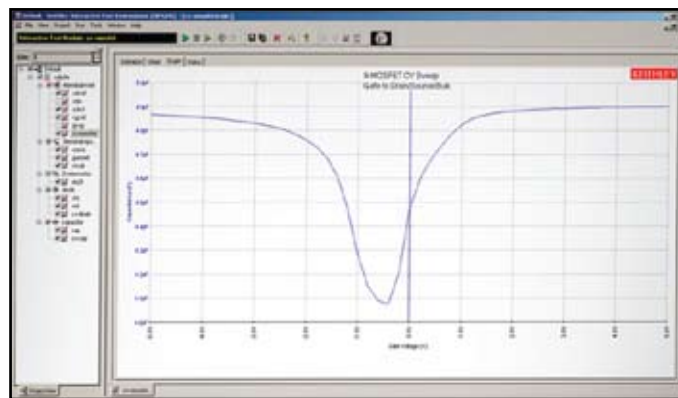

1.888.KEITHLEY (U.S. only)

www.keithley.com

KEITHLEY

A GREATER MEASURE OF CONFIDENCE

4205-PG2 Dual-Channel Pulse Generator Specifications ^{1, 2}

The 4205-PG2 includes three operational modes for flexible, reconfigurable pulsing:

- Standard pulse
 - Pulse between any two voltage levels
 - Period range: 20ns to 1s
- Arbitrary (ARB) waveform
 - Output ARB waveforms built from standard wave libraries or sampled data
 - Depth: 256K points/channel
 - Timebase: 20ns/point up to 1sec/point, fixed timebase for entire waveform
 - Waveform Libraries: sine, ramp, gaussian, white noise
 - Input in .csv format
- Segment ARB™ waveform
 - With a single pulse channel, build multi-level and multi-pulse waveforms with user-defined line segments
 - Depth: 1024 segments/channel
 - Parameters for each segment: Segment #, start voltage, stop voltage, segment time, trigger out, High Endurance Output relay (HEOR/SSR) on/off
 - Time per segment: 20ns to 1s, 10ns increments (each segment can have a different duration)

PULSE/LEVEL³

		High Speed	High Voltage
V_{OUT}	50 Ω into 50 Ω	-5V to +5V	-20V to +20V
V_{OUT}	50 Ω into 1 M Ω	-10V to +10V	-40V to +40V
Accuracy		$\pm(3\% + 50 \text{ mV})$	$\pm(3\% + 100 \text{ mV})$
Amplitude/Level	50 Ω into 50 Ω	1 mV	5 mV
Resolution	50 Ω into 1 M Ω	2 mV	10 mV
Output Connectors		SMA	SMA
Source Impedance		50 Ω Nominal	50 Ω Nominal
		1%	1%
Short Circuit Current		$\pm 200 \text{ mA}$	$\pm 800 \text{ mA}$
Current into 50 Ω Load (at full scale)		$\pm 100 \text{ mA}$ typical	$\pm 400 \text{ mA}$ typical
Baseline Noise		$\pm(0.1\% + 5 \text{ mV})$ RMS typical	$\pm(0.1\% + 5 \text{ mV})$ RMS typical
Overshoot/Pre-shoot/Ringing		$\pm 5\%$ of amplitude $\pm 20 \text{ mV}$	$\pm 5\%$ of amplitude $\pm 80 \text{ mV}$
Output Limit		Programmable limit to protect the DUT	

TIMING

	High Speed	High Voltage	
Frequency Range	1 Hz to 50 MHz	1 Hz to 2 MHz	
Timing Resolution	10 ns	10 ns	
RMS Jitter (period, width)	0.01 % + 200 ps typical	0.01 % + 200 ps typical	
Period Range	20 ns to 1 s	500 ns to 1 s	
Accuracy	$\pm 1\%$	$\pm 1\%$	
Pulse Width Range	10ns to (period - 10ns)	250ns to (period - 100ns)	
Accuracy	$\pm(3\% + 200 \text{ ps})$	$\pm(3\% + 5 \text{ ns})$	
Programmable Transition Time (0-100%)	10 ns-33 ms	100 ns-33 ms	
Transition Slew Rate ⁴	Accuracy	$\pm 1\%$ for transition time <100 ns	$\pm 1\%$ for transition time <1 μs
	Linearity	3% for transition time <100 ns	3% for transition time <500 ns
Typical Minimum Transition Time 10-90%	Pulse Period and width are variable in 10 ns steps without any output glitches or dropouts		
Solid state relay	Open or close time	100 μs	100 μs

TRIGGER

TRIGGER OUTPUT IMPEDANCE: 50 Ω .

TRIGGER OUTPUT LEVEL: TTL.

TRIGGER IN IMPEDANCE: 10k Ω .

TRIGGER IN LEVEL: TTL.

TRIGGER IN TRANSITION TIMING, MAXIMUM: <100ns.

TRIGGER IN TO PULSE OUT DELAY: 560ns.

TRIGGER SYNCHRONIZATION/JITTER⁵: <8ns.

NOTES

1. Unless stated otherwise, all specifications assume a 50 Ω termination.
 2. Maximum number of PG2 cards depends on number and type of cards in the 4200 chassis.
 3. Level specifications are valid after 50ns typical settling time (after slewing) for the high speed mode and after 500ns typical settling time (after slewing) for the high voltage mode into a 50 Ω load
 4. Specifications apply to a 10-90% transition, typical. Minimum slew rate for high speed range = 724mV/ms. For high voltage range = 2.71V/ms, which applies to both the standard pulse and Segment ARB™ mode
 5. For multiple 4205-PG2 cards, when using appropriate cabling and the "trigger per waveform" trigger mode
- All specifications apply at 23° \pm 5°C, within one year of calibration, RH between 5% and 60%, after 30 minutes of warmup.

1.888.KEITHLEY (U.S. only)

www.keithley.com

KEITHLEY

A GREATER MEASURE OF CONFIDENCE

4200-SCP2 1.25GS Dual-Channel Oscilloscope Card and 4200-SCP2HR 200MS Dual-Channel Oscilloscope Card Specifications¹

ANALOG INPUT¹

	4200-SCP2	4200-SCP2HR
No. of Channels	2	2
Bandwidth (50Ω)	DC to 750 MHz	DC to 250 MHz, typical
Bandwidth (1MΩ)	DC to 350 MHz	DC to 125 MHz, typical
Full Scale Input Range (50 Ω)	0.05, 0.1, 0.25, 0.5, 1, 2, 5, 10 (Vp-p)	0.05, 0.1, 0.25, 0.5, 1, 2, 5, 10 (Vp-p)
Full Scale Input Range (1 MΩ)	0.1, 0.2, 0.5, 1, 2.5, 5, 10, 20, 50, 100 (Vp-p)	0.25, 0.5, 1.25, 2.5, 5, 10, 25, 50 (Vp-p)
DC Gain Accuracy	<±1% of full scale	< ±0.25% of full scale
Impedance	1 MΩ 12 pF or 50 Ω	1 MΩ 12 pF or 50 Ω
Impedance Accuracy	±1%	±1%
Coupling	DC or AC	DC or AC
Offset Adjust	±(full scale range/2)	±(full scale range/2)
Offset Accuracy	±(1% offset + 1% full scale)	±1%
Input Connectors	BNC	BNC
Absolute Maximum Input (50 Ω)	±5V DC	±5V DC
Absolute Maximum Input (1 MΩ)	±210V DC	±210V DC

ANALOG-TO-DIGITAL CONVERTER

	4200-SCP2	4200-SCP2HR
Resolution	8 bit	16 bit
Sample Rate	2.5 kS/s to 1.25 GS/s in 1, 2.5, 5 steps 2.5 GS/s (1 channel interleaved)	10 kS/s to 200 MS/s in 1, 2.5, 4, 5 steps 400 MS/s (1 channel interleaved)
Memory Depth	1 MS/channel	1 MS/channel
Acquisition Time Range	2 MS on 1 channel, interleaved 50 ns to 419 seconds	2 MS on 1 channel, interleaved 250 ns to 3,355 seconds
Acquisition Modes	Normal, Average, Envelope, and Equivalent-time	Normal, Average, Envelope, and Equivalent-time

TRIGGER

	4200-SCP2	4200-SCP2HR
Trigger Source	Channels 1 or 2, External, Pattern, Software	Channels 1 or 2, External, Pattern, Software
Post-Trigger Delay	0 to 655 seconds	0 to 655 seconds
Pre-Trigger Delay	0 to waveform time	0 to waveform time
Trigger Hold Off Range	0 to 655 seconds	0 to 655 seconds
Trigger Modes	Edge or Pulse Width	Edge or Pulse Width
Edge Trigger Mode	Rising or Falling Edge	Rising or Falling Edge
Pulse Width Range	20ns to 655 seconds, 10ns resolution	20ns to 655 seconds, 10ns resolution
External Trigger Input	TTL Compatible, 10 kΩ input impedance	TTL Compatible, 10 kΩ input impedance
Connector	SMB	SMB

OPTIONAL SCOPE PROBE: 4200-SCP2-ACC

BANDWIDTH: 70MHz (4200-SCP2); 15MHz (4200-SCP2HR).

ATTENUATION: 1×

MAX DC: 300V DC rated.

LOADING: 100pF and 1MΩ.

LENGTH: 1m.

CONNECTOR: BNC.

NOTES

1. Inputs are referenced to 4200 chassis ground

All specifications apply at 23°±5°C, within 1 year of calibration, RH between 5% and 60%, after 30 minutes of warmup.

4200-PIV-A Pulse I-V Option

The 4200-PIV-A package combines the 4205-PG2 dual-channel pulse generator with the 4200-SCP2 oscilloscope, a specialized interconnect, and patented software to provide a turnkey pulse I-V solution. The software controls sourcing from the pulse generator and data acquisition from the digital oscilloscope to automate a variety of pulse I-V tests. The specialized interconnect solves most of the problems typically encountered in high speed pulse testing:

- Combining pulse and DC sources to a single DUT pin permits both DC and pulse characterization without the need for re-cabling or switching
- Impedance matching, which minimizes reflection and maintains pulse fidelity
- Easy setup as a result of straightforward cabling and connection to the DUT

Pulse I-V for leading-edge CMOS devices:

- Pulse voltage on gate, DC bias on drain
- Measure drain current during gate pulse
- $\pm 5V$ pulses for the gate (40ns to 150ns), $\pm 200V$ DC for the drain

Included tests:

- $V_{DS}-I_D$: Both pulse and DC.
- $V_{GS}-I_D$: Both pulse and DC.
- Single-pulse scope view: Useful for setup validation, pulse width optimization, and prototyping of novel pulse tests.

4200 PIV-A for CMOS Typical Specifications¹

CHANNELS: 2.

TYPICAL PULSE PERFORMANCE (with 4205 Remote Bias Tee⁴):

Measurement Accuracy: <4% of signal $\pm 1mV$.

Maximum Current Measure: 100mA.

Resolution: 100nA².

Offset: <500nA.

Sample Rate: 1GS/s.

Duty Cycle: <0.1%.

DC Offset: $\pm 200V$.

Minimum Transition Time (10–90%): <15ns.

Pulse Source Voltage Range: 0 to $\pm 5V$ into gate.

Pulse Width: 40ns to 150ns.

SMU TYPICAL DC PERFORMANCE (with 4205 Remote Bias Tee):

Leakage: 1–10nA/V³.

Noise: 1–10nA RMS.

Maximum Voltage: 210V (>40V requires safety interlock and related precautions).

Maximum Current: 0.5A.

4200 REMOTE BIAS TEE TYPICAL PERFORMANCE:

Band Pass: 3.5kHz–300MHz (3dB).

Power Divider Max Power Input: 0.125W DC.

NOTES

1. Unless stated otherwise, all specifications assume a 50 Ω termination.
2. When using Adaptive filtering.
3. Leakage measured after a 5 second settling time.
4. All typical specs apply to the AC+DC output connector of the 4205 Remote Bias Tee and after system compensation.

All specifications apply at 23 $\pm 5^\circ C$, within one year of calibration, RH between 5% and 60%, after 30 minutes of warmup.

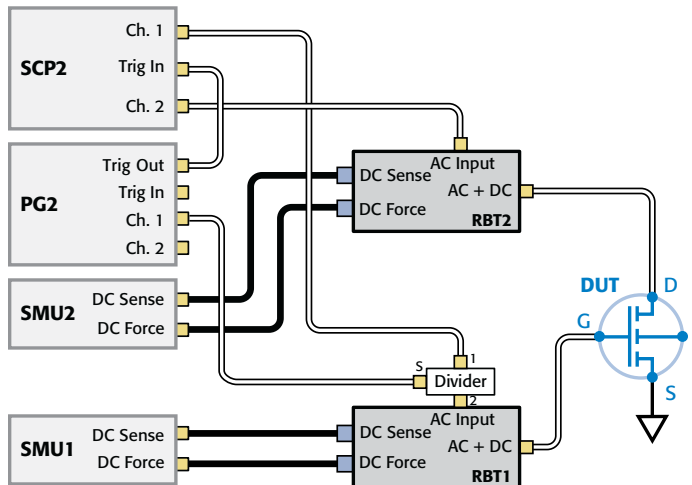

Interconnection for 4200-PIV-A for leading edge CMOS, high κ , and isothermal testing. PIV-A pulses the voltage on the gate and provides a DC bias on the drain.

1.888.KEITHLEY (U.S. only)

www.keithley.com

KEITHLEY

A GREATER MEASURE OF CONFIDENCE

4200-PIV-Q Pulse I-V with Q point and Dual Channel Pulsing

The 4200-PIV-Q package is designed for quiescent point pulsing for scaled-down RF transistors, such as HEMT and FET devices in III-V or LDMOS technologies. This package supports multiple 4205-PG2s and the 4200-SCP2HR oscilloscope and includes capabilities such as dual-channel pulsing (i.e., for pulsing on both the gate and the drain simultaneously), higher power pulsing than the 4200-PIV-A package, and pulsing from a non-zero quiescent point. Pulse widths can be adjusted from 500ns to near-DC, and the same setup can also be used for performing true DC tests without re-cabling the system. The PIV-Q package is useful for a variety of large signal tests on high frequency transistors, as well as for investigation of dispersion phenomena and device performance at speed. It also offers a good approach for avoiding the isothermal problems inherent in DC testing.

Dual-channel pulse I-V testing for III-V and LDMOS:

- Pulse voltage on gate and drain.
- Measure: gate current and drain voltage and current.
- $\pm 20V$ pulses for the gate, $\pm 38V$ pulses for the drain.⁶
- Pulse Widths: 500ns to 999ms.

Included tests:

- $V_{DS}-I_D$: Both pulse and DC.
- $V_{GS}-I_D$: Both pulse and DC.
- Single-pulse scope view: Useful for setup validation, pulse width optimization, prototyping of novel pulse tests.

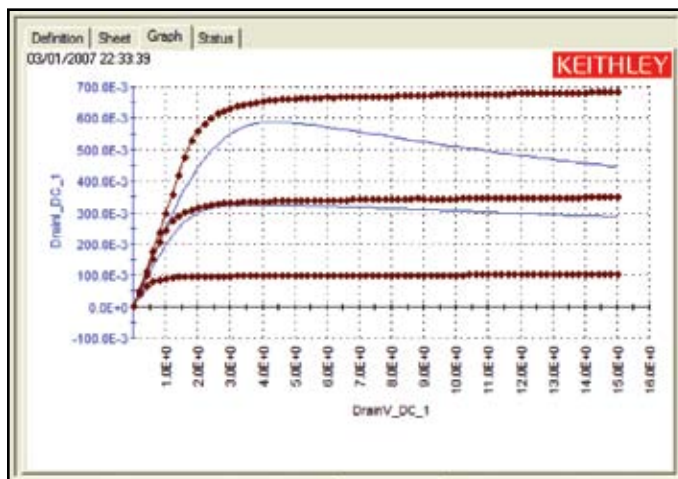

4200-PIV-Q Typical Specifications¹

CHANNELS: 2.

TYPICAL PULSE PERFORMANCE:⁴

Measurement Accuracy: Gate Current: $<50\mu A$ offset, $10\mu A$ resolution.²
 Drain Current: $<100\mu A$ offset, $10\mu A$ resolution.²

Maximum Current Measure: Gate: $100mA$ into 50Ω .⁵
 Drain: $760mA$ into 50Ω , $1.33A$ into 5Ω .⁶

Sample Rate: 200MS/s.

Minimum Transition Time (10–90%): 150ns.

Gate Pulse Source: $-20V$ to $+20V$.

Drain Voltage Range: $-38V$ to $+38V$ (into 50Ω), $\pm 75V$ (into $1k\Omega$).⁶

Pulse Width: 500ns to 999ms.

Pulse Period: 510ns to 1s.

Duty Cycle: 0.001% to 99.9%.

SMU TYPICAL DC PERFORMANCE:

Typical DC Leakage, Gate: $<20nA$ offset for $<35V$.

Typical DC Leakage, Drain: $<10nA/V^3$ for $<35V$.

Typical DC Noise, Gate: $<20nA$ RMS.

Gate Offset: $<20nA$.

Typical DC Noise, Drain: $<300pA$ RMS.

Maximum Voltage: 210V ($>40V$ requires safety interlock and related precautions).

Maximum Current: 1A.⁵

NOTES

1. Unless stated otherwise, all specifications assume a 50Ω termination.
2. Offset and resolution specified when using adaptive filtering.
3. Leakage measured after a 5 second settling time.
4. All typical specs apply to the AC+DC output cable (from the SMU Force, connected to the SMA tee attached to Triax to SMA adapter) after system compensation.
5. For the high power 4210-SMU. For the medium power 4200-SMU, the maximum current is 100mA.
6. Drain Pulse Source is a voltage pulser with 55Ω output impedance. To calculate the approximate maximum Drain current for any DUT resistance:
 $I_{dmax} = 80V/55 + R_{DS}$
 To calculate approximate maximum Drain voltage, input the I_{dmax} calculated above:
 $V_{dmax} = I_{dmax} \times R_{DS}$
 For more information, refer to the tables titled "Maximum Drain Source" and "Maximum Gate Source."
 Also see the figure titled "Maximum Pulse Drain I and V vs. DUT Drain-Source Resistance."

All specifications apply at $23^\circ \pm 5^\circ C$, within 1 year of calibration, RH between 5% and 60%, after 30 minutes of warmup.

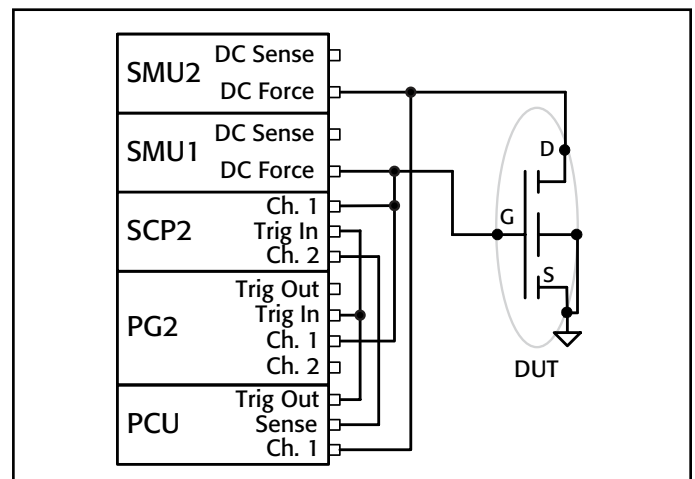

Interconnection for 4200-PIV-Q for III-V and LDMOS scaled-down RF transistors. PIV-Q pulses voltage on both the gate and drain from non-zero bias (quiescent) conditions.

4200-PIV-Q Typical Specifications (continued)

MAXIMUM DRAIN SOURCE (40V Range), typical

Maximum V_D^* (V)	Maximum I_D^* (A)	R_{DS} (Ω)
6.65	1.33	5
12.3	1.23	10
25	1.0	25
38	0.76	50
50	0.54	92
51.6	0.51	100
65	0.26	250
75.8	0.075	1k

*Approximate maximum, does not account for interconnect losses.

MAXIMUM GATE SOURCE (20V Range), typical

Maximum V_G^* (V)	Maximum I_G^* (A)	R_{GS} (Ω)
3.6	0.769	5
6.67	0.667	10
13.3	0.533	25
20	0.400	50
25.9	0.280	92
26.7	0.267	100
33.3	0.133	250
38.1	0.038	1k

*Approximate maximum, does not account for interconnect losses.

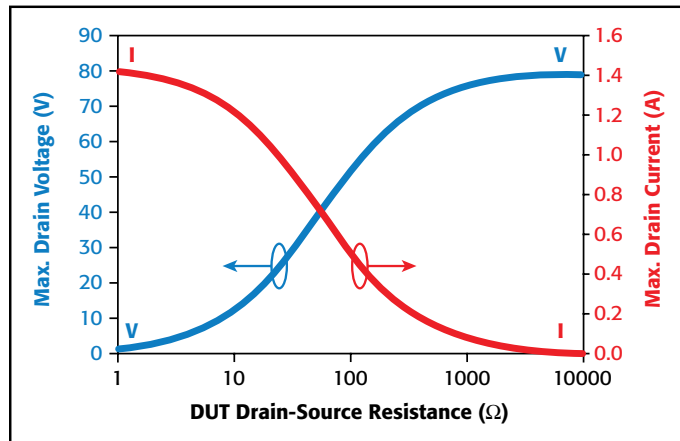

Maximum Pulse Drain I and V vs. Drain-Source Resistance

STABILIZATION KIT

The stabilization kit for the 4200-PIV-Q, the 4200-Q-STBL-KIT, minimizes the oscillations caused by III-V RF transistors and LDMOS RF devices. The stabilization kit includes 10 resistors and 2 blanks for customization.



Stabilization resistor



10 resistors (+ 2 blanks) in the kit

4200-FLASH Non-volatile Memory Test Option

The 4200-FLASH package tests single FLASH memory cells or small arrays. This package includes all the necessary code and the interconnect needed to perform a standard set of Flash memory tests for NAND or NOR technologies, with higher pulse voltages important for MLC technologies. The tests included generate program and/or erase cycles using the patent-pending Segment ARB™ pulse mode as well as controlling the in-line High Endurance Output Relay. Endurance and Disturb tests are also included.

Four channels of multi-level pulse:

- ±40V pulsing into high impedance pin (±20V into 50Ω).
- High Endurance Output Relay provides fast open/close for pin isolation during erase pulse.
- Pulse Widths: 200ns to 1s.
- Up to 25 pulse levels (100 pulse segments).

Included tests:

- Endurance.
- Program-read.
- Erase-read.
- Disturb.

	Start (V)	Stop (V)	Time (s)	Trig (1/0)	SSR (1/0)
1	0	1	2.00E-08	1	1
2	1	1	1.00E-07	1	1
3	1	0	2.00E-08	0	0
4	0	0	1.00E-07	0	0

Easy setup for program/erase cycles

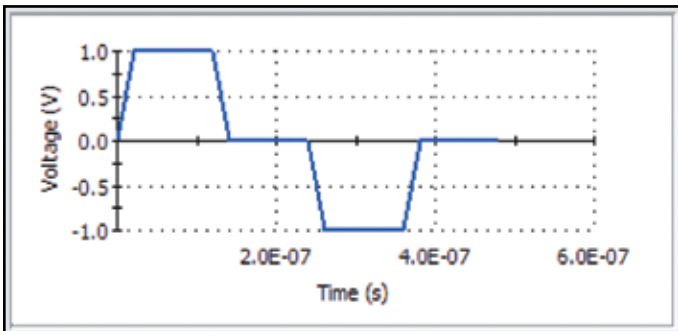

Typical NOR FLASH gate program/erase cycle

4200-FLASH Typical Specifications¹

CHANNELS: 4 channels (optional 8 channels max.).

TYPICAL PULSE PERFORMANCE:

Number of Voltage Levels/Waveform: 25.

Minimum Transition Time: 150ns.

Pulse Source Voltage Range: 0 to ±20V into 50Ω. 0 to ±40V into high impedance.

Pulse Width: 250ns to 1s.

Trigger Synchronization/Jitter: ±8ns.

Switching Time for DUT Pin Isolation: 100μs.

HEOR Off Capacitance: 250pF.

SMU TYPICAL DC PERFORMANCE

Typical DC Leakage: <10nA/V² for <35V.

Typical DC Noise: <300pA RMS.

Maximum Voltage: 200V (>40V requires safety interlock and related precautions).

Maximum Current: 1A.³

NOTES

1. Unless stated otherwise, all specifications assume a 50Ω termination.
2. Leakage measured after a 5 second settling time.
3. For the high power 4210-SMU. For the medium power 4200-SMU, the maximum current is 100mA.

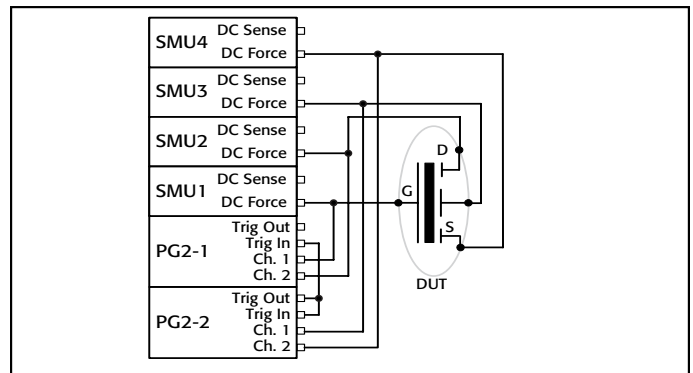

Interconnect for 4200-FLASH for single DUT, shown with four SMUs and no external switch matrix. FLASH provides pulsing for program, erase, and P+E stress waveforms and DC for Vt measurements.

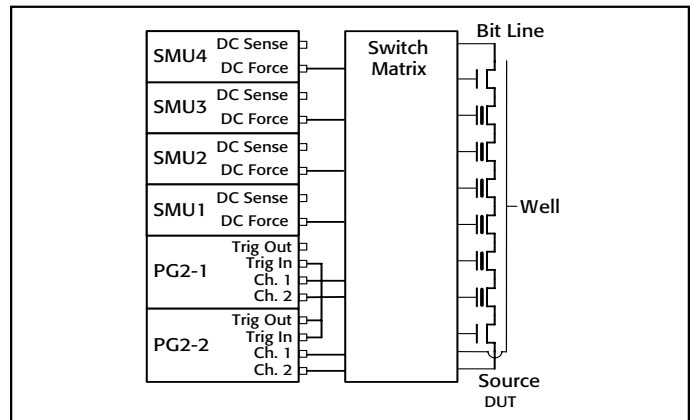

Interconnect for 4200-FLASH for addressable device, shown with four SMUs and external switch matrix. FLASH provides pulsing for program, erase, and P+E stress waveforms and DC for Vt measurements.

KTE Interactive Software Tools

KTE Interactive includes a variety of software tools for operating and maintaining the 4200-SCS:

- Keithley Interactive Test Environment (KITE)—The 4200-SCS device characterization application
- Keithley User Library Tool (KULT)—Allows test engineers to integrate custom algorithms into KITE using 4200-SCS or external instruments.
- Keithley Configuration Utility (KCON)—Allows test engineers to define the configuration of GPIB instruments, switch matrices, and analytical probes connected to the 4200-SCS. It also provides system diagnostics functions.
- Keithley External Control Interface (KXCI)—The 4200-SCS application for controlling the 4200-SCS from an external computer via the GPIB bus or Ethernet.
- KPulse—A graphical user interface (GUI) that is a non-programming alternative to configure and control the installed Model 4205-PG2 pulse generator cards. It is used for quick tests requiring minimal interaction with other Model 4200-SCS test resources.
(Note: KPulse is only included with the 4205-PG2, 4200-PIV-A, 4200-PIV-Q, and 4200-FLASH.)
- KScope—A graphical user interface (GUI) that provides a non-programming alternative to control the system's scope card (either Model 4200-SCP2HR or Model 4200-SCP2).
(Note: KScope is only included with the 4200-SCP2, 4200-SCP2HR, 4200-PIV-A, and 4200-PIV-Q.)

Microsoft Windows

Windows Operating System

The operating system is a standard distribution of Microsoft Windows. Upgrades are available for older systems. Contact the Keithley factory for supported versions and service packs.

Data Security and Recovery

Data security and recovery are handled by the included software package, Acronis True Image. This utility can be used to create exact hard disk images, including all operating systems, applications and configuration files, software updates, personal settings, and data. If failures occur that block access to information or affect system operation, or if files are accidentally deleted, the user can easily restore the system and lost data with the Acronis tool.

Data Storage

Fixed disk

Internal high capacity fixed disk drive stores the operating system, application programs, and data files.

CD-RW Drive

Standard CD read-write drive is provided for data storage and retrieval.

USB Ports

Three USB ports for typical PC USB peripherals.

Connectivity

The 4200-SCS includes a 10/100BASET Ethernet interface with software drivers installed.

The Keithley Interactive Test Environment (KITE)

The Keithley Interactive Test Environment (KITE) is the Model 4200-SCS Windows device characterization application. It provides advanced test definition, parameter analysis and graphing, and automation capabilities required for modern semiconductor characterization.

KITE Projects

A project is a collection of related tests, organized in a hierarchy that parallels the physical layout of the devices on a wafer. KITE operates on projects using an interface called the project navigator. The project navigator simplifies organizing test files, test execution, and test sequencing.

The project navigator organizes tests into a logical hierarchy presented in a browser style format. This structure allows users to define projects around wafer testing:

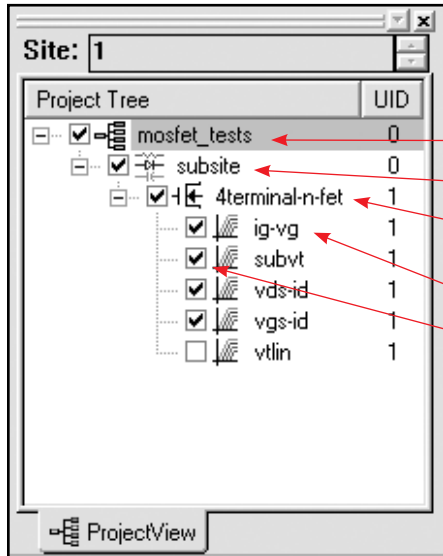

The project level organizes subsites and controls wafer looping execution.

The subsite level organizes devices and controls subsite test sequencing.

The device level organizes test modules, manages test module libraries, and controls device test sequencing.

The test module level performs tests, analyzes data, and plots results.

Selectable checkboxes allow enabling/disabling individual tests/plans.

Test Modules

Within KITE, two types of test modules are provided to capture the test input parameters, data analysis, and plot setting for data. “Interactive Test Modules” provide a point-and-click interface for defining test input parameters and controlling the 4200-SCS SMUs. “User Test Modules” provide a fill-in-the-blank interface to either factory-provided or user-written C language subroutines. These subroutines can control internal 4200-SCS instruments and/or external instruments and systems through the RS-232 or GPIB interface. This dual approach provides an extendable test environment that gives the users the same capabilities for data analysis, plotting, and output and automation, whether the instrument used is part of the base system or an external instrument. It also offers users the flexibility to write complex test algorithms for control of either internal or external instruments.

Definition Tab—Interactive Test Module

The Definition Tab of an ITM provides a point-and-click interface for setting test input parameters that control the 4200-SCS SMUs and defining parameter extractions. Two modes are available:

Sweep Mode

Forcing Functions:	Common, Voltage Bias, Current Bias (VMU), Voltage Sweep, Current Sweep, Voltage Step, Current Step, Voltage List Sweep, Current List Sweep, Open ^{1,2}
--------------------	---

Measuring Functions:	Measure Current or Programmed Current, Measure Voltage or Programmed Voltage.
----------------------	---

Fast, Normal, Quiet, and Custom Integration Times

Measure voltage, current or both on each sweep point, regardless of forcing function.

1. Pulse SMU: The system's SMUs can now be set to provide pulse output for sweep (linear, log, and list) and bias forcing functions. This involves having the SMU pulse, which is different than the PG2 pulse mode. Pulse “on” and “off” times can be set from 5ms to 10s. Pulse output goes to the specified pulse level during the pulse “on” time and back to a user-defined base voltage during the “off” time. If the SMU is also set to measure, the measurement will occur after the “on” time expires and before the transition to the “off” time level. If it's not set to measure, the output will simply transition from “on” to “off.”
2. Standby: There's a new checkbox in the Timing window called “Disable outputs at completion,” which is checked by default. If this box is unchecked, the SMU outputs will stay at their last values when the test is complete (instead of returning to zero or “idle” state). These values then change when a new test is started (if that particular SMU is required in the new test), or KITE is exited, or a UTM calls a “DEVINT.”

Interactive Test Modules (ITM) are built from three different major functions: Definition, Sheet, and Graph. The Definition Tab allows the operator to define a sweep or sampling mode test using a graphical approach. The Sheet Tab stores acquired data and provides an Excel®-like workbook for viewing and analyzing test results. The Graph Tab provides a full-featured data plotting tool capable of producing report-ready graphs. The Status Tab reports any errors that would interfere with test execution.

Sampling Mode

Linear sampling of up to 4096 points. Sampling period is programmable from 1ms to 1000s. Additional hold delay before first sample of up to 1000s.

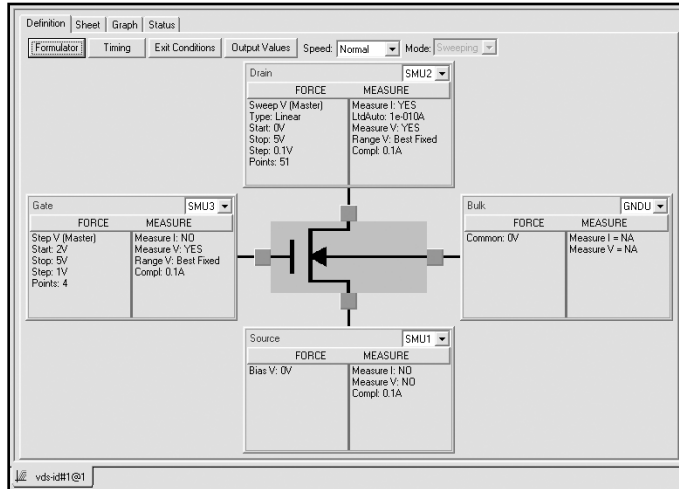

Definition Tab—User Test Module

The Definition Tab of a UTM presents users a tabular fill-in-the-blank interface for entering input parameters to call a C language subroutine. UTMs provide the ability to control internal SMUs and GPIB and RS-232 devices. This screen allows the user to select a user library, a subroutine module, and then enter the desired input parameters. Test results are returned to the Sheet Tab for viewing and analysis. Select UTMs have a GUI interface to simplify operation.

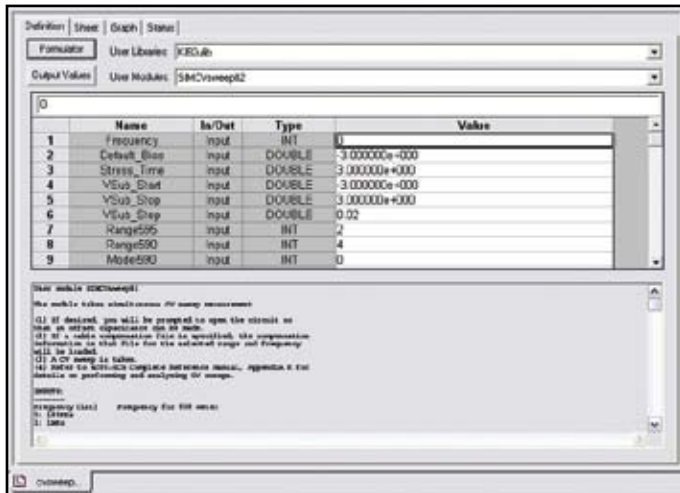

The User Test Module (UTM) has virtually identical functionality as the ITM. However, users enter input parameters in a tabular interface in the UTM's Definition Tab.

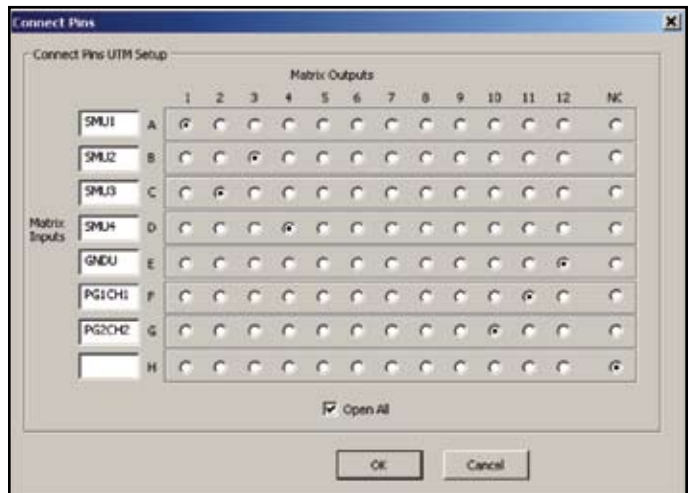

GUI to control switch matrix UTMs.

Data Analysis

Two methods of parameter extraction are available. The Formulator provides automated line fits and parameter extraction. A spreadsheet offers standard spreadsheet analysis tools.

Formulator functions

The Formulator performs data transformations for performing parameter analysis and line fits. The Formulator supports the following functions:

- **Mathematical Functions**

Addition (+), subtraction (-), division (/), multiplication (*), exponent (^), absolute value (ABS), value at an index position (AT), Average (AVG), moving average (MAVG), conditional computation (COND), derivative (DELTA), differential coefficient (DIFF), exponential (EXP), square root (SQRT), natural logarithm (LN), logarithm (LOG), integral (INTEG), standard deviation (STDEV), moving summation (SUMMV), arc cosine (ACOS), arc sine (ASIN), arc tangent (ATAN), cosine (COS), sine (SIN), tangent (TAN)

- **Conversion Functions**

Radians to degrees (DEG), degrees to radians (RAD)

- **Line Fits and Parameter Extraction Functions**

Exponential line fit (EXPFIT), coefficient a (EXPFITA), coefficient b (EXPFITB)

Linear Fit (LINFIT), linear slope (LINFITSLP), x intercept (LINFITXINT), y intercept (LINFITYINT)

Logarithmic line fit (LOGFIT), coefficient a (LOGFITA), coefficient b (LOGFITB)

Linear Regression line fit (REGFIT), slope (REGFITSLP), x intercept (REGFITXINT), y intercept (REGFITYINT)

Tangent line fit (TANFIT), slope (TANFITSLP), x intercept (TANFITXINT), y intercept (TANFITYINT)

Maximum value (MAX), minimum value (MIN), midpoint (MEDIAN)

- **Search Functions**

Find Down (FINDD), Find Up (FINDU), Find using linear interpolation (FINDLIN)

Maximum position (MAXPOS), minimum position (MINPOS)

First Position (FIRSTPOS), Last Position (LASTPOS)

Sub Array (SUBARRAY), return a specified number of points (INDEX)

Formulator Constants

The Formulator supports user-supplied constants for use in parameter extractions. These constants are factory installed:

$PI = 3.14159 \text{ rad } (\pi)$

$K = 1.38065 \times 10^{-23} \text{ J/K}$ (Boltmann's constant)

$Q = 1.60218 \times 10^{-19} \text{ C}$ (Charge of electron)

$M_0 = 9.10938 \times 10^{-31} \text{ kg}$ (Electron mass)

$E_v = 1.60218 \times 10^{-19} \text{ J}$ (Electron voltage)

$U_0 = 1.25664 \times 10^{-6} \text{ N/A}^2$ (Permeability)

$E_0 = 8.85419 \times 10^{-12} \text{ F/m}$ (Permittivity of a vacuum)

$H = 6.62607 \times 10^{-34} \text{ J-s}$ (Planck's constant)

$C = 2.99792 \times 10^8 \text{ m/s}$ (Speed of light)

$KT/Q = 0.02568 \text{ V}$ (Thermal voltage)

1.888.KEITHLEY (U.S. only)

www.keithley.com

KEITHLEY

A GREATER MEASURE OF CONFIDENCE

Sheet Tab—Data Viewing and Analysis

The Sheet Tab of a test module captures data from a test execution and allows calculations in a spreadsheet. The Sheet Tab operates like an Excel workbook with the following spreadsheets: the Data sheet, the Calc sheet, the Settings sheet, and the Append sheets.

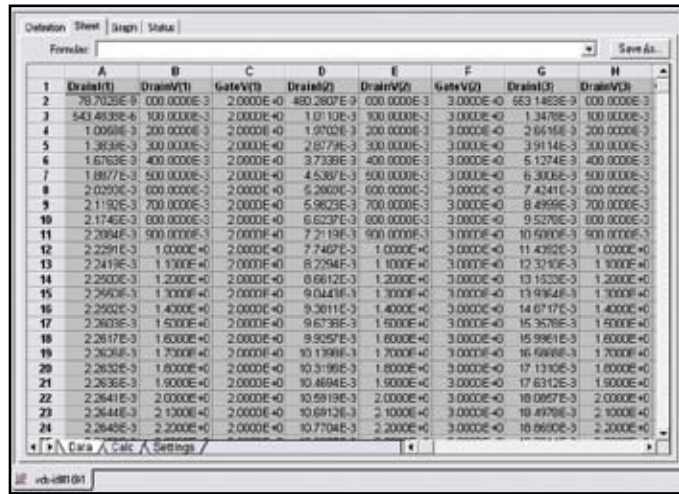

Data Sheet

The Data sheet displays test results in real time. It is read-only so that results cannot be modified.

Calc Sheet

A spreadsheet that operates much like a standard Microsoft Excel spreadsheet is available for computation with each test. The spreadsheet tool supports these functions:

Functions in the KITE Calc sheet

ABS	ACOS	ACOSH	ASIN	ASINH
ATAN	ATAN2	ATANH	AVERAGE	COS
COSH	EXP	FIXED	IF	LN
LOG	LOG10	LOOKUP	MATCH	MAX
MIN	NOW	SINH	PRODUCT	ROUND
SIGN	SIN	SINH	SQRT	STDEV
SUM	SUMSQ	TAN	TANH	VAR

Settings Sheet

The Settings sheet stores the test setup so that when the Sheet tab is exported as a workbook, users can refer to the test configuration.

Append Sheet

Append sheets store test results when the Append button is clicked. Data in Append sheets can be automatically plotted on the graph. Test modules support up to 40 Append sheets.

Graph Tab—Plotting

The Graph Tab is a full-featured plotting tool for creating report-ready graphs. It allows real-time X-Y plotting of acquired and extracted data with one or two Y axes.

- Linear, Semilog, and Log/Log graphs.
- Real-time auto scaling, end of test auto scaling, or manual scaling.
- Six cursors with X-Y readout.
- Graphical line fitting.
- Plot overlay of multiple test executions.
- Four data variable readouts.
- User-formatted comment box, title, and axis labels.
- Choice of engineering units on axes: V (volts), A (amps), s (seconds), S (Siemens), F (farads), Hz (Hertz).
- Choice of engineering symbols on axes: m, μ , n, etc.

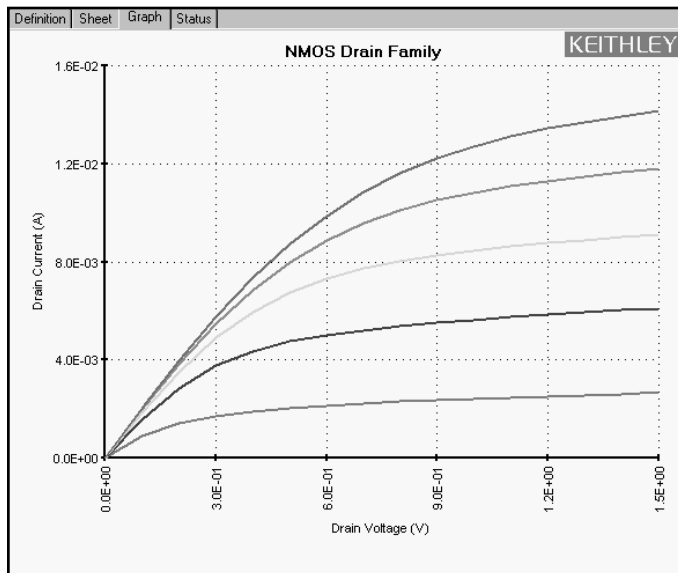

Output

Files

- Sheet tab test results can be saved as a Microsoft Excel Workbook or delimited ASCII text file.
- Plots can be saved as bit map image (.bmp), JPEG (.jpg), or TIFF (.tif) files.

Display

- Flat Panel: 1024 × 768 resolution.
- External SVGA: 1024 × 768 or 800 × 600 resolution.

Printers

- A generic printer driver is factory installed using standard Windows printer support.

Example Projects

The 4200-SCS includes the following KITE projects to facilitate rapid startup and provide examples for common semiconductor lab applications.

Default Project

Default—The default project includes standard tests for MOSFETs, BIPOLAR transistors, resistors, and diodes. This project helps users get started quickly.

Memory Projects

These projects test floating gate FLASH and embedded NVM memory. They test up to four independent, multi-level pulse channels with up to $\pm 40V$ pulsing on the gate. The waveforms can be predefined or custom. These projects also offer three types of DUT setups: NAND, NOR, and switch based.

Flash-NOR, Flash-NAND, Flash-Switch—These projects provide the ability to send n pulses to the DUT, then perform a V_T sweep. The tests in these projects support four- and eight-terminal testing and allow investigation into program and erase state dependencies on pulse parameters using three types of waveforms: program, erase, and fast program erase. Flash-Switch also includes automatic control of Keithley's Model 707A or Model 708A Switch Matrix.

FlashDisturb-NOR, FlashDisturb-NAND, FlashDisturb-Switch—The Disturb tests pulse stress a device in an array test structure, then perform a measurement, such as V_T , on a device adjacent to the pulsed device. The goal is to measure the amount of V_T shift in adjacent cells, either in the programmed or erased states, when a nearby device is pulsed with either program, erase, or program+erase waveforms. FlashDisturb-Switch also includes automatic control of Keithley's Model 707A or Model 708A Switch Matrix.

FlashEndurance-NOR, FlashEndurance-NAND, FlashEndurance-Switch—These projects pulse stress the DUT with a number of Program+Erase waveform cycles, then periodically measure the V_T . The purpose of these projects is to determine the lifetime of the DUT, based on the number of program+erase cycles withstood by the device before a certain amount of shift, or degradation, in the V_T or other measurement. They also control in-line solid-state relays for the erase waveform cycle. FlashEndurance-Switch also includes automatic control of Keithley's Model 707A or Model 708A Switch Matrix.

CMOS Project

CMOS-default—The tests in this project include the most common CMOS device tests that a typical user might perform on a daily basis.

BJT Project

BJT-default—The tests in this project represent the most common BJT tests that a typical user might perform on a daily basis.

Reliability Projects

EM_const_I—Tests electromigration using constant current. It also controls a hot chuck.

HCI_1_DUT—This is a Hot Carrier Injection (HCI) project on one 4-terminal N-MOSFET. No switch matrix is involved in the measurement. Parameters monitored between two successive stresses include I_{Doff} .

1.888.KEITHLEY (U.S. only)

www.keithley.com

KEITHLEY

A GREATER MEASURE OF CONFIDENCE

I_{Don} , I_G , V_T , and G_m . Those parameters are measured on both forward (normal operation condition) and reverse (reverse source and drain bias) conditions. If only a subset of these parameters is needed, it is possible to deselect the test(s) that include the unwanted parametric measurements. It is also possible to add custom tests that will be monitored between successive stresses.

HCI_4_DUT—This is a Hot Carrier Injection (HCI) project on two 4-terminal N-MOSFETs and two 4-terminal p-MOSFETs with a switch matrix. Parameters monitored between two successive stresses include I_{Doff} , I_{Don} , I_G , V_T , and G_m . Those parameters are measured on both forward (normal operation condition) and reverse (reverse source and drain bias) conditions. If only a subset of these parameters is needed, it is possible to deselect the test(s) that include the unwanted parametric measurements. It is also possible to add custom tests that will be monitored between successive stresses. Also, if less than four devices are tested, it is possible to deselect the unwanted device plan in the project tree or modify it for more devices.

HCI_PULSE—This Hot Carrier Injection (HCI) project tests one 4-terminal N-MOSFET using AC stress. It is similar to HCI_1_DUT.

NBTI_1_DUT—This is a Negative Bias Temperature Instability (NBTI) project on one 4-terminal P-MOSFET. Parameters monitored between two successive stresses include I_{Doff} , I_{Don} , I_G , V_T , and G_m . If only a subset of these parameters is needed, it is possible to deselect the test(s) that include the unwanted parametric measurements. It is also possible to add custom tests that will be monitored between successive stresses.

Qbd—This charge-to-breakdown project consists of two Q_{BD} tests on gate dielectrics (V-Ramp and J-Ramp). Those two tests follow JEDEC Standard 35-A. An additional test performs an I-V measurement under normal work conditions to obtain input parameters for the V-Ramp and J-Ramp tests.

Pulse Projects

Chargepumping—This project consists of Charge Pumping (CP) tests that characterize interface and charge-trapping phenomena. There are a variety of tests, including base sweep, amplitude sweep, rise time linear sweep, fall time linear sweep, frequency linear sweep, and frequency log sweep.

ChargeTrapping—The Charge Trapping project uses a single pulse technique to look at device charge trapping and de-trapping behavior within a single, well-configured gate pulse. During the rise and fall times of the voltage ramp, the corresponding drain current response is captured, allowing appropriate $V_{\text{GS}}-I_D$ curves to be formed.

ivpswitch_340x—The tests in this project demonstrate automated device testing using a 4200-SCS, a Keithley Model 3402 pulse generator, and a switch matrix.

ivpswitch—The tests in this project demonstrate automated device testing using a 4200-SCS, an HP8110A/81110A pulse generator, and a switch matrix.

PulseIV-Complete—This project provides PIV (pulse IV) tests, including tests that generate I_D vs. V_D graphs and I_D vs. V_G graphs as well as tests that show the effect of self-heating on devices due to DC voltages. (This is the primary sample project included in the 4200-PIV-A package.)

QPulseIV-Complete—This project includes PIV-Q tests that generate I_D vs. V_D and I_G vs. V_D graphs for a FET as well as calibration routines. This

project is used to run characterization curves on III-V and LDMOS high power devices using the pulse technique and a non-zero quiescent point. (This is the primary sample project in the 4200-PIV-Q package.)

Nanotechnology Project

NanoDevices—This project is designed specifically for Nanotechnology applications and includes the most common tests for nanowires, nanotubes, molecular and CNT transistors, and biocomponents.

C-V Projects

CVU_BJT—Measures capacitance (at 0V bias) between terminals, including C_{be} , C_{bc} , and C_{ec} .

CVU_Capacitor—Performs both a C-V sweep and a C-f sweep on a Metal-Insulator-Metal (MIM) capacitor and calculates standard deviation.

CVU_InterconnectCap—Measures C-V of small interconnect capacitance on wafer.

CVU_ivcswitch—Demonstrates using DC SMUs, 4200-CVU, and 707A/708A (switch matrix) in one project. Switches back and forth between DC and C-V tests and connections to the DUT.

CVU_Lifetime—Determines generation velocity and lifetime testing (Zerbst plot) of MOS capacitors.

CVU-MobileIon—Determines mobile charge using the bias-temperature stress method. Extracts flatband voltage. Includes built-in control of a hot chuck to test a sample at room temperature, heated, then tested again at room temperature to determine flatband shift.

CVU_MOScap—Measures C-V on a MOS capacitor. Extracted parameters include oxide capacitance, oxide thickness, doping density, depletion depth, Debye length, flatband capacitance, flatband voltage, bulk potential, threshold voltage, metal-semiconductor work function difference, and effective oxide charge.

CVU_MOSFET—Makes a C-V sweep on a MOSFET device. Extracted/calculated parameters include oxide thickness, oxide capacitance, flatband capacitance, flatband voltage, threshold voltage, and doping concentration as a function of depletion depth.

CVU_nanowire—Makes a C-V sweep on a two-terminal nanowire device.

CVU_PNjunction—Measures the capacitance of a p-n junction or Schottky diode as a function of the DC bias voltage across the device.

CVU_PVcell—Measures both forward and reverse biased DC characteristics of an illuminated solar cell and extracts parameters such as max power, max current, max voltage, short-circuit current, open-circuit voltage, and efficiency. Also performs characteristic C-V and C-f sweeps.

default—Standard C-V sweeps for generic MOSFETs, diodes, and capacitors.

ivcswitch—The tests in this project demonstrate the 4200-SCS's integrated I-V, C-V, switching, and probing capabilities.

lifetime—The lifetime project performs high frequency C-t measurements using the Keithley System 82 on MOS capacitors. The minority carrier recombination lifetime and surface velocity are extracted using a Zerbst Plot.

1.888.KEITHLEY (U.S. only)

www.keithley.com

KEITHLEY

A GREATER MEASURE OF CONFIDENCE

SIMCV—This project provides routines for simultaneous C-V measurement using the Keithley System 82. Typical MOS device parameters, such as doping profile, flat band voltage, threshold voltage, interface trap density, and band bending are extracted.

STVS—This project uses the Keithley System 82 to perform an STVS (Simultaneous Triangular Voltage Sweep) measurement at high temperature. Mobile ion density is extracted.

Miscellaneous Projects

FourPtProbe—This project enables users to make four-point collinear probe measurements on semiconductor materials.

ivswitch—The ivswitch project integrates control of a Keithley Model 707A or Model 708A external switch matrix with device testing.

probesites—The probesites project illustrates how KITE controls semi-automatic probe stations for automated probing of one subsite per site on a single wafer.

probesubsites—The probesubsites project illustrates how KITE controls semi-automatic probe stations when testing multiple subsites per site on a single wafer.

vdp_resistivity—This project enables users to make Van der Pauw measurements on semiconductor materials.

Demonstration Projects

Demo-Default—The tests in this project demonstrate the most common DC tests on an FET. Also, new features that were recently introduced are demonstrated, including pulse SMU, dual sweep, and selecting Engineering labels for the axes.

Demo-PulseIV—This project demonstrates PIV (pulse I-V) tests, including tests that generate I_D vs. V_D graphs and I_D vs. V_G graphs as well as tests that show the effect of self heating on devices due to DC voltages. It also provides a test that demonstrates the oscilloscope. (This project is included in the 4200-PIV-A package.)

Automation Test Sequencing

The Keithley Interactive Test Environment (KITE) provides “point and click” test sequencing on a device, a group of devices (subsite, module, or test element group), or a user-programmable number of probe sites on a wafer.

Prober Control

Keithley provides integrated prober control for supported analytical probes when test sequencing is executed on a user-programmable number of probe sites on a wafer. Contact the factory for a list of supported analytical probes. A “manual” prober mode prompts the operator to perform prober operations during the test sequence.

Supported Probers

Manual Prober

Use the manual prober driver to test without utilizing automatic prober functionality. Manual prober replaces all computer control of the prober with that of the operator. At each prober command, a dialog box will appear, instructing the operator what operation is required.

Fake Prober

The Fake prober is useful when prober actions are not desired, such as when debugging, without having to remove prober commands from a sequence.

Supported Semi-automatic (Analytical) Probers

Cascade Microtech Summit™ 12K Series, verified with Nucleus UI

Karl Suss Model PA-200, verified with Wafermap for ProberBench NT, NI-GPIB Driver for ProberBench NT, PBRS232 Interface for ProberBench NT, Navigator for ProberBench NT, Remote Communicator for ProberBench NT

MicroManipulator 8860 Prober, verified with pcBridge, pcLaunch, pcIndie, pcWfr, pcNav, pcRouter

Signatone CM500 driver also works with other Signatone probes with interlock controller such as the WL250 and S460SE

Keithley User Library Tool (KULT)

The Keithley User Library Tool supports creating and integrating C-language subroutine libraries with the test environment. User library modules are accessed in KITE through User Test Modules. Factory supplied libraries provide up and running capability for supported instruments. Users can edit and compile subroutines, then integrate libraries of subroutines with KITE, allowing the 4200-SCS to control an entire test rack from a single user interface. KULT is derived from the Keithley S600 and S400 Series Parametric Test Systems. This simplifies migration of test libraries between the 4200-SCS and Keithley parametric test systems.

Standard User Libraries

The 4200-SCS includes the following useful subroutine libraries, which provide “out of the box” integration and control of Keithley switch matrix systems and other common device characterization equipment. Users access these libraries with the UTM definition tab described on page 16.

chargepumping

This library can be used to study charge trapping and new charge creation on a high κ -Si interface and within high κ film.

hotchuck-tempronics-3010b

This user library controls the temperature of Tempronics 3010b hotchucks. This library sets the target temperature and waits until the target is reached before exiting.

hotchuck_triotech

The hotchuck_triotech user library controls the temperature of TrioTek hot chucks. This library sets the target temperature and waits until the target is reached before exiting.

hp4284ulib

The hp4284ulib user library performs capacitance measurements and C-V sweeps using the Agilent 4284A or 4980 LCR meter.

hp4294ulib

The hp4294ulib user library performs capacitance measurements, C-V sweeps, and frequency sweeps using the Agilent 4294 LCR meter. This library also includes calibration routines to perform phase, open, short, and load calibrations.

hp8110ulib

The hp8110ulib user library performs initialization, setup, and triggering for the Agilent HP8110A (or 81110A) pulse generator.

ki42xxulib

The ki42xxulib user library provides an example subroutine for performing a MOSFET ON resistance (R_{ON}) test routine using the 4200-SCS LPTLIB interface.

ki82ulib

The ki82ulib user library performs simultaneous C-V, C-t, and Q/t Simultaneous C-V System.

ki340xulib

For use with Keithley Series 3400 pulse/pattern generators.

ki590ulib

The ki590ulib user library performs conductance measurements and 100kHz or 1MHz capacitance measurements, C-V sweeps, C-V pulse

sweeps, C-t sweeps, and cable compensation for the Keithley Model 590 C-V Analyzer.

ki595ulib

The ki595ulib user library performs Q/t sweeps and C-V sweeps using the Keithley Model 595 Quasistatic C-V Meter.

kipulseulib

The kipulseulib UTMs control the Model 4205-PG2 pulse card.

kiscopeulib

The kiscopeulib UTMs control either the Model 4200-SCP2HR or 4200-SCP2 oscilloscope.

matrixulib

The matrixulib user library connects instrument terminals to output pins using a Keithley 707A or 708A switch system when configured as a general-purpose (Model 4200-GP-RS-XX), low current (Model 4200-LC-LS-XX) or ultra-low current matrix (Model 4200-UL-RS-XX or Model 4200-UL-LS-XX).

parlib

The parlib user library is used for extracting device parameters on bipolar and MOSFET transistors. Extracted parameters include Beta, resistance, threshold voltage, and $V_{DS}-I_D$ sweeps and $V_{GS}-I_D$ sweeps for MOSFETs.

prbgen

The prbgen user library provides test modules to initialize the prober driver, move to the next site or subsite in the prober's wafer map, make or break contact between the probes and the wafer, and obtain the X position and Y position of the prober. Contact the factory for supported probers.

winulib

The winulib user library provides user interface routines for operator inputs and prompts, such as the abort, retry, and ignore decision prompts.

wrlib

The wrlib user library includes routines for performing linear regression and charge-to-breakdown tests (Q_{BD}) on gate dielectrics. Included modules are qbd_rmpv (V-Ramp method) and qbd_rmpj (J-Ramp method).

C language

Microsoft Visual C++ Standard Edition provides the compiler for the Keithley User Library Tool. Users can develop test subroutine libraries using the full capabilities of C-language programming.

LPTLIB Control

The LPTLIB provides an application programming interface for developing C-language test routines that control integrated test hardware and supported external instruments and switches. This simple connect/source/measure approach eliminates the need for low-level programming and allows the user to focus on creating new test routines quickly. The 4200-SCS LPTLIB is derived from the Keithley S600 series and S400 series parametric test systems to simplify migration of test routines between the 4200-SCS and Keithley parametric test systems.

1.888.KEITHLEY (U.S. only)

www.keithley.com

KEITHLEY

A GREATER MEASURE OF CONFIDENCE

System Configuration and Diagnostics (KCON)

The Keithley Configuration Utility (KCON) simplifies programming and maintaining a fully integrated test station. KCON provides a single interface for configuring external instruments, switch matrices, and analytical probes, and for executing system diagnostics.

External Instrument Configuration

KCON allows lab managers to integrate external instruments with the 4200-SCS and a supported switch matrix. After the user configures the GPIB addresses for supported instruments, Keithley-supplied libraries will function and test modules can be transferred between 4200-SCS systems without any user modification. In addition to the standard supported instruments, the General Purpose Instrument allows users to develop subroutines and control switches for a generic two-terminal or four-terminal instrument. For the widest possible system extensibility, users can develop their own test libraries for general purpose instruments.

Switch Matrix Configuration

Users define the connection of 4200-SCS instruments and external instruments to device under test (DUT) pins through a supported switch matrix configuration. (See Switch Matrix Support and Configurations). Once connections are defined, users need only enter the instrument terminal name and pin number to establish connections. The 4200-SCS applications and standard user libraries manage the routing of test signals between instrument terminals and DUT pins. The user doesn't need to remember and program row and column closures. Test modules can transfer between 4200-SCS systems without re-entering connection information.

4200-SCS Instrument Diagnostics

Users can confirm system integrity of SMUs, C-V measurement unit, pulse generator, oscilloscopes, and Remote PreAmps by running a system self-test. For more complex problems, the system's configuration analysis tool can generate reports that assist Keithley's Technical Support staff in diagnosing problems.

Keithley External Control Interface (KXCI)

KXCI allows you to use an external computer to control the SMUs, C-V measurement unit, pulse generator cards, and oscilloscope in the Model 4200-SCS remotely over GPIB or Ethernet. When controlled by an external computer, the Model 4200-SCS functions like any other GPIB instrument.

The KXCI GPIB command set is similar to the command set used by the Agilent Model 4145B. This similarity allows many programs already developed for the Agilent model to be used by the Model 4200-SCS.

Accessories and Optional Instrumentation

Accessories Supplied for DC SMUs

4200-MTRX-2	Ultra Low Noise SMU Triax Cable (Two supplied for each SMU), 2m (6.6 ft). Not included with SMUs configured with a 4200-PA Remote PreAmp.
4200-TRX-2	Ultra Low Noise PreAmp Triax Cable, 2m (6.6 ft). Two supplied for Ground Unit. Two supplied in replacement of 4200-MTRX-2 cables for each SMU configured with a 4200-PA.
4200-RPC-2	Remote PreAmp Cable (One supplied for each PreAmp), 2m (6.6 ft).
236-ILC-3	Interlock Cable, 3m (10 ft).
Line Cord	NEMA 5-15P for 100-115VAC or CEE 7/7 (Continental European) for 240VAC.
User Manual	User Manual and Reference Manual supplied on the 4200-SCS Complete Reference CD-ROM. (Printed manual available as an option.)

Accessories Supplied with 4200-CVU

CA-447A	Four SMA Cables, male to male, 100Ω, 1.5m
CS-1247	Four Female SMA to Male BNC Adapters
CS-701	Two BNC Tee Adapters
TL-24	One SMA Torque Wrench

Accessories Supplied with 4200-CVU-Prober-Kit

CA-446A	Four SMA Cables, 100Ω, 3m
CS-565	Four Female BNC to Female BNC Adapters
237-TRX-BAR	Four Female Triax to Female Triax Adapters
7078-TRX-GND	Four Male Triax to Female BNC Adapters (guards removed)
7078-TRX-BNC	Four Male Triax to Female BNC Adapters
CS-1247	Four Female SMA to Male BNC Adapters
CS-1391	Two SMA Tee Adapters (female, male, female)
4200-PRB-C	Two SSMC to SMA Cables with local ground

Optional Instrumentation

4200-CVU	Integrated C-V Instrument
4200-CVU-PROBER-KIT	Optional accessory kit for connection to popular analytical probes
4200-SMU	Medium Power Source-Measure Unit for 4200-SCS. 100mA to 100fA, 200V to 1μV, 2 Watt
4210-SMU	High Power Source-Measure Unit for 4200-SCS. 1A to 100fA, 200V to 1μV, 20 Watt
4200-PA	Remote PreAmp Option for 4200-SMU and 4210-SMU, extends SMU to 0.1fA resolution
4205-PG2	Dual-Channel Pulse Generator
4200-SCP2	Dual-Channel Integrated Oscilloscope
4200-SCP2HR	High Resolution, Dual-Channel Integrated Oscilloscope
4200-SCP2-ACC	Optional Scope Probe

Application Packages

4200-PIV-A	Complete Pulse I-V Package for leading edge CMOS
4200-PIV-Q	Pulse I-V Package with Q Point and Dual-Channel Pulsing
4200-FLASH	Non-volatile Memory Test package

NOTE: Page 28 lists all optional accessories.

1.888.KEITHLEY (U.S. only)

www.keithley.com

KEITHLEY

A GREATER MEASURE OF CONFIDENCE

Support Contracts

Base System

4200-3Y-EW	1-year factory warranty on the base 4200-SCS (including all SMUs and PAs) extended to 3 years from date of shipment. Includes calibration (reports compliant to ANSI Z540-1) and return shipping.
4200-5Y-EW	1-year factory warranty on the base 4200-SCS (including all SMUs and PAs) extended to 5 years from date of shipment. Includes calibration (reports compliant to ANSI Z540-1) and return shipping.
4200-3Y-CAL	3 calcs within 3 years of purchase of the base 4200-SCS (including all SMUs and PAs) . Before and after data reports compliant with ANSI/NCSL Z540-1. Does not cover Scope Cards or Pulse Gen Cards.
4200-5Y-CAL	5 calcs within 5 years of purchase of the base 4200-SCS (including all SMUs and PAs) . Before and after data reports compliant with ANSI/NCSL Z540-1. Does not cover Scope Cards or Pulse Gen Cards.

PIV, Pulse, Scope, C-V, and Flash options

4200-CVU-1Y-EW	1 year of return to factory repairs of the 4200-CVU C-V Measurement Unit from date of shipment. Must be purchased with 4200-1Y-EW and 4200-CAL.
4200-CVU-3Y-EW	1-year factory warranty on the 4200-CVU C-V Measurement Unit extended to 3 years from date of shipment. Includes calibration and return shipping. Requires purchase of 4200-3Y-EW.
4200-CVU-5Y-EW	1-year factory warranty on the 4200-CVU C-V Measurement Unit extended to 5 years from date of shipment. Includes calibration and return shipping. Requires purchase of 4200-5Y-EW.
4200-CVU-3Y-CAL	3 calcs within 3 years of purchase of the 4200-CVU C-V Measurement Unit. Requires purchase of 4200-3Y-CAL.
4200-CVU-5Y-CAL	5 calcs within 5 years of purchase of the 4200-CVU C-V Measurement Unit. Requires purchase of 4200-5Y-CAL.
4205-PG2-3Y-EW	1-year factory warranty on the 4205-PG2 Pulse Generator Card extended to 3 years from date of shipment. Includes calibration and return shipping. Requires purchase of 4200-3Y-EW.
4205-PG2-5Y-EW	1-year factory warranty on the 4205-PG2 Pulse Generator Card extended to 5 years from date of shipment. Includes calibration and return shipping. Requires purchase of 4200-5Y-EW.
4205-PG2-3Y-CAL	3 calcs within 3 years of purchase of the 4205-PG2 Pulse Generator Card. Requires purchase of 4200-3Y-CAL.
4205-PG2-5Y-CAL	5 calcs within 5 years of purchase of the 4205-PG2 Pulse Generator Card. Requires purchase of 4200-5Y-CAL.

4200-SCP2-3Y-EW	1-year factory warranty on the 4200-SCS Scope Card (Standard or HR version) extended to 3 years from date of shipment. Includes calibration and return shipping. Requires purchase of 4200-3Y-EW.
4200-SCP2-5Y-EW	1-year factory warranty on the 4200-SCS Scope Card (Standard or HR version) extended to 5 years from date of shipment. Includes calibration and return shipping. Requires purchase of 4200-5Y-EW.
4200-SCP2-3Y-CAL	3 calcs within 3 years of purchase of the 4200-SCS Scope Card (Standard or HR version). Requires purchase of 4200-3Y-CAL.
4200-SCP2-5Y-CAL	5 calcs within 5 years of purchase of the 4200-SCS Scope Card (Standard or HR version). Requires purchase of 4200-5Y-CAL.
4200-PIV-A-3Y-EW	1-year factory warranty on the 4200-PIV-A Package extended to 3 years from date of shipment. Includes calibration and return shipping. Requires purchase of 4200-3Y-EW.
4200-PIV-A-5Y-EW	1-year factory warranty on the 4200-PIV-A Package extended to 5 years from date of shipment. Includes calibration and return shipping. Requires purchase of 4200-5Y-EW.
4200-PIV-A-3Y-CAL	3 calcs within 3 years of purchase of the 4200-PIV-A Package. Requires purchase of 4200-3Y-CAL.
4200-PIV-A-5Y-CAL	5 calcs within 5 years of purchase of the 4200-PIV-A Package. Requires purchase of 4200-5Y-CAL.
4200-PIV-Q-3Y-EW	1-year factory warranty on the 4200-PIV-Q extended to 3 years from date of shipment. Includes calibration and return shipping. Requires purchase of 4200-3Y-EW.
4200-PIV-Q-5Y-EW	1-year factory warranty on the 4200-PIV-Q extended to 5 years from date of shipment. Includes calibration and return shipping. Requires purchase of 4200-5Y-EW.
4200-PIV-Q-3Y-CAL	3 calcs within 3 years of purchase of the 4200-PIV-Q. Requires purchase of 4200-3Y-CAL.
4200-PIV-Q-5Y-CAL	5 calcs within 5 years of purchase of the 4200-PIV-Q. Requires purchase of 4200-5Y-CAL.
4200-FLASH-3Y-EW	1-year factory warranty on the 4200-FLASH extended to 3 years from date of shipment. Includes calibration and return shipping. Requires purchase of 4200-3Y-EW.
4200-FLASH-5Y-EW	1-year factory warranty on the 4200-FLASH extended to 5 years from date of shipment. Includes calibration and return shipping. Requires purchase of 4200-5Y-EW.
4200-FLASH-3Y-CAL	3 calcs within 3 years of purchase of the 4200-FLASH. Requires purchase of 4200-3Y-CAL.
4200-FLASH-5Y-CAL	5 calcs within 5 years of purchase of the 4200-FLASH. Requires purchase of 4200-5Y-CAL.

1.888.KEITHLEY (U.S. only)

www.keithley.com

KEITHLEY

A GREATER MEASURE OF CONFIDENCE

Value-Add Services

4200-APPS-DAY	One 8-hour day of applications assistance. Travel expenses not included for on-site assistance.
IMPL-4200	One 8-hour day of on-site implementation. An Applications Engineer will visit your facility and get your 4200-SCS implemented for your application. Includes unpack, installation, setup, configuration, and basic training on product usage. Does not include travel expenses.
APPS SERVICE	<p>Customized applications assistance. Examples include:</p> <ul style="list-style-type: none"> • Software services – KULT/UTM development and customization • Applications assistance – test plan development, test process optimization, measurement troubleshooting • System development – integration of a 4200-SCS with other elements of a test system, such as a switch matrix or a C-V meter
TRN-4200-1-K	Two-day training class at Keithley, “Optimizing the Use of Your 4200-SCS Semiconductor Characterization System.” Two days in-depth, hands-on training on how to unleash the powerful capabilities of your 4200-SCS. Includes theory of operation, product operation, making measurements, optimizing measurements, and troubleshooting. See website for dates and locations.
TRN-4200-1-C	On-site training, per day, for up to 6 people. Additional charges for larger audience. Travel expenses not included.
TRN-4200-1-R	Remote (web-based) training, per hour.

Upgrades

Besides the upgrades listed below, the optional instrumentation listed on page 23 can also be added as upgrades.

4200-UPGRADE	<p>4200-SCS Hardware Upgrade Service Includes installation of new instruments, calibration, and verification. This item must be included, in addition to the price of any instruments purchased, when a system is returned to the factory for an instrumentation upgrade (adding SMUs or PreAmps). This fee is charged only once for an upgrade event. The customer may add any quantity or type of instrument to their system for the upgrade fee. The service fee includes a system burn-in and calibration. This service fee does not apply to software upgrades or Model 4200-CPU-2GH/C and 4200-CPU-2GH/F upgrades. Does not include shipping.</p>
4200-KTEI-x.x	4200-SCS Keithley Test Environment Interactive (KTEI) software test suite (latest version); includes KTEI Vx.x CD and Complete Reference Vx.x CD.
4200-CPU-2GH/C	4200-SCS upgrade service; includes installation of new 2GHz single board computer (w/512MB SDRAM, 100-BaseT network port, ATI M6 graphics controller), three USB 1.1 ports (two front, one back), fresh installation of Windows XP Professional operating system (not upgrade—See Note). Also includes installation of Model 4200-KTEI-x.x software test suite (latest version) (for 4200-SCS/C (CRT) systems only).
4200-CPU-2GH/F	Same as 4200-CPU-2GH/C except for 4200-SCS/F (Flat Panel) systems only.

Note: The 4200-CPU-2GH/C and -F upgrades restore the 4200-SCS to factory conditions. The hard drive is reformatted and all old data and projects will NOT be preserved. Be sure to back up all data and projects prior to ordering either of these upgrades.

Approved Third-Party Software:

- Acronis True Image (OEM)
- Adobe Acrobat Reader 7.0 or later
- Adobe Acrobat 7.0 or later
- Diskeeper 9.0 or later
- Microsoft Excel
- Microsoft Word
- Internet Explorer 5.0 or later
- Norton AntiVirus 2000 6.0 or later
- Visual C++ .net
- Windows XP Professional
- Symantec pcAnywhere 11.0

Warranty Information Warranty Summary

This section summarizes the warranties of the 4200-SCS. For complete warranty information, refer to the 4200-SCS Reference Manual. Any portion of the product which is not manufactured by Keithley is not covered by this warranty and Keithley will have no duty to enforce any other manufacturer's warranties.

Hardware Warranty

Keithley Instruments, Inc. warrants the Keithley manufactured portion of the hardware for a period of one year from defects in materials or workmanship; provided that such defect has not been caused by use of the Keithley hardware which is not in accordance with the hardware instructions. The warranty does not apply upon any modification of Keithley hardware made by the customer or operation of the hardware outside the environmental specifications.

Software Warranty

Keithley warrants for the Keithley produced portion of the software or firmware will conform in all material respects with the published specifications for a period of ninety (90) days; provided the software is used on the product for which it is intended in accordance with the software instructions. Keithley does not warrant that operation of the software will be uninterrupted or error-free, or that the software will be adequate for the customer's intended application. The warranty does not apply upon any modification of the software made by the customer.

Embedded PC Policy

Caution: Keithley Instruments warrants the performance of the Model 4200-SCS only with the factory-approved Windows Operating System and applications software pre-installed on the 4200-SCS by Keithley Instruments. Systems that have been modified by the addition of un-approved third-party application software (software that is not explicitly approved and supported by Keithley Instruments) are not covered under the product warranty. Model 4200-SCS systems with unapproved software may need to be restored to factory approved condition before any warranty service can be performed (e.g., calibration, upgrade, technical support). Services provided by Keithley Instruments to restore systems to factory approved condition will be treated as out-of-warranty services with associated time and material charges. Approved software is listed in the Reference Manual and under "Approved Third-Party Software" on page 25 of this document.

CAUTION: DO NOT reinstall or upgrade the Windows operating system (OS) on any Model 4200-SCS. This action should only be performed at an authorized Keithley service facility. Violation of this precaution will void the Model 4200-SCS warranty and may render the Model 4200-SCS unusable. Any attempt to reinstall or upgrade the Windows operating system will require a return-to-factory repair and will be treated as an out-of-warranty service, including time and material charges.

Switch Matrix Support and Configurations Overview

A number of useful standard switch matrix configurations are available for the 4200-SCS. Each standard configuration includes all components, cabling, and instructions for the user to assemble the switch matrix and add the matrix configuration to the 4200-SCS test environment. Once a supported configuration is added to the test environment, the 4200-SCS standard user library (matrixlib) connects instrument terminals to output pins through a simple "fill-in-the-blank" interface.

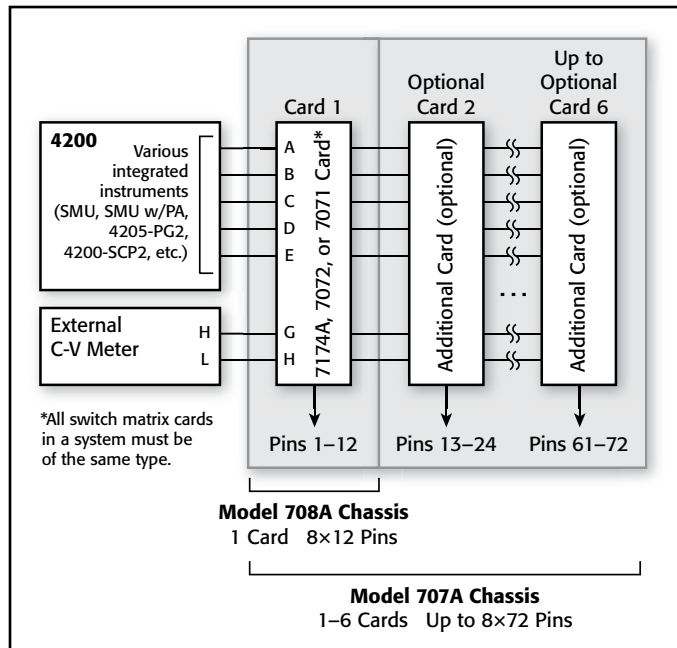

Basic block diagram of 4200-SCS configurations

1.888.KEITHLEY (U.S. only)

www.keithley.com

KEITHLEY

A GREATER MEASURE OF CONFIDENCE

Ultra-Low Current/Local Sense Configuration (4200-UL-LS-XX)

The Ultra-Low Current/Local Sense switch configuration is built using the Keithley Model 7174A Low Current Matrix Card (with the Model 707A or 708A Switch Matrix), which is designed for semiconductor research, development, and production applications requiring high quality, high performance switching of I-V and C-V signals. This configuration provides eight instrument inputs with up to 72 output pins at only 10fA typical offset current.

4200-UL-LS-12 (or -12/707A)

- 1 708A (or 707A) Switch Mainframe
- 1 7174A Switch Card
- 12 4200-TRX-3 Cable for each 12 pins
- 1 7007-1 IEEE Cable
- 2 7078-TRX-BNC Adapter
- 1 7078-PEN Light Pen

Connector Type: 3-lug triax.

Maximum Signal Level: 200V, 2A.

Offset Current: 100fA max, 10fA typical.

Maximum Leakage: 0.01pA/V.

3dB Bandwidth: 30MHz typical.

Ultra-Low Current/Remote Sense Configuration (4200-UL-RS-XX)

Remote sensing is more accurate for voltage sourcing and measuring, particularly at currents greater than approximately 10mA, but degrades the performance of C-V meters and pulse generators. The Ultra-Low Current/Remote Sense switch configuration is built using the Keithley Model 7174A Low Current Matrix Card, which is designed for semiconductor research, development and production applications requiring high quality, high performance switching of I-V and C-V signals. The configuration provides six instrument inputs with up to 30 output pins at only 10fA typical offset current.

4200-UL-RS-6, -12, -18, -24, -30

- 1 707A Switch Mainframe
- 1 7174A Switch Card for input
- 1 7174A Switch Card for each 6 DUT pins
- 12 4200-TRX-3 Cable for each 6 DUT pins
- 1 7007-1 IEEE Cable
- 2 7078-TRX-BNC Adapter
- 1 7078-PEN Light Pen

Connector Type: 3-lug triax.

Maximum Signal Level: 200V, 2A.

Offset Current: 100fA max, 10fA typical.

Maximum Leakage: 0.01pA/V.

Low Current/Local Sense Configuration (4200-LC-LS-XX)

The Low Current/Local Sense switch configuration is built using the Keithley Model 7072 Semiconductor Matrix Card, which is designed for semiconductor applications requiring good quality I-V and C-V signals. The configuration provides eight instrument inputs with up to 72 output pins with less than 1pA offset current.

4200-LC-LS-12 (or -12/707A)

- 1 708A (or 707A) Switch Mainframe
- 1 7072 Matrix Switch Card
- 12 4200-TRX-3 Cable
- 1 7007-1 IEEE Cable
- 2 7078-TRX-BNC Adapter
- 1 7078-PEN Light Pen

4200-LC-LS-24, -36, -48, -60, -72

- 1 707A Switch Mainframe
- 1 7072 Matrix Switch Card for each 12 pins
- 12 4200-TRX-3 Cable for each 12 pins
- 1 7007-1 IEEE Cable
- 2 7078-TRX-BNC Adapter
- 1 7078-PEN Light Pen

Connector Type: 3-lug triax.

Maximum Signal Level: 200V, 1A.

Offset Current: <1pA (Rows A–B).

Maximum Leakage: 0.1pA/V.

3dB Bandwidth: 5MHz typical (Rows G–H).

General-Purpose/Remote Sense Configuration (4200-GP-RS-XX)

The General-Purpose/Remote Sense switch configuration is built using the Keithley Model 7071 General-Purpose Matrix Card, which is designed for applications requiring cost-effective switching of I-V and C-V signals. Remote sensing is more accurate for voltage sourcing and measuring, particularly at currents greater than approximately 10mA. The configuration provides eight instrument inputs with up to 72 output pins with less than 100pA offset current. Each crosspoint provides HI, LO, and GUARD signal switching.

4200-GP-RS-12 (or -12/707A)

- 1 708A (or 707A) Switch Mainframe
- 1 7071 Switch Card
- 1 7078-MTC-20 Cable
- 1 7007-1 IEEE Cable
- 1 7078-PEN Light Pen

4200-GP-RS-24, -36, -48, -60, -72

- 1 707A Switch Mainframe
- 1 7071 Switch Card for each 12 pins
- 1 7078-MTC-20 Cable for each 12 pins
- 1 7007-1 IEEE Cable
- 1 7078-PEN Light Pen

Maximum Signal Level: 200V, 1A.

Offset Current: <100pA.

Maximum Leakage: 100pA/V.

3dB Bandwidth: 5MHz typical.

Connector Type: Quick disconnect using 38-pin connectors or screw terminals.

Optional Accessories

COMPUTER OPTIONS

4200-MOUSE Microsoft Ambidextrous 2 Button Mouse (Note: a pointing device is integrated with the 4200 keyboard.)

REMOTE PREAMP MOUNTING ACCESSORIES

4200-MAG-BASE¹ Magnetic base for mounting 4200-PA on a prober platen
 4200-TMB² Triaxial mounting bracket for mounting 4200-PA on a triaxial mounting panel
 4200-VAC-BASE² Vacuum base for mounting 4200-PA on a prober platen

CABINETS AND MOUNTING ACCESSORIES

4200-CAB-20UX 20U Cabinet (35 in.)
 4200-CAB-25UX 25U Cabinet (44 in.)
 4200-CAB-34UX 34U Cabinet (60 in.)
 4200-KEY-RM Slide Rack Mounting Kit for standard keyboard and pointing device
 4200-RM Slide Rack Mounting Kit for 4200-SCS/F and 4200-SCS/C
 4205-PCU-313B Support Bracket

CONNECTORS, ADAPTERS, AND FIXTURES

237-BAN-3A Triax Cable Center Conductor terminated in a safety banana plug
 237-BNC-TRX Male BNC to 3-lug Female Triax Adapter
 237-TRX-BAR 3-lug Triax Barrel for use with triax interconnect
 237-TRX-T 3-slot Male to Dual 3-Lug Female Triax Tee Adapter
 237-TRX-TBC 3-lug Female Triax Bulkhead Connector
 7078-TRX-BNC Coaxial Connector for connecting coax instruments to a triax matrix
 7078-TRX-GND Male Triax to Female BNC Connector (guards removed)
 8101-4TRX 4-pin Transistor Fixture
 8101-PIV Pulse I-V Demo Fixture
 CA-404B SMA Plug to SMA Plug, RG188, 2m
 CA-405B SMA Plug to SMA Plug, RG188, 6in
 CA-406B SMA Plug to SMA Plug, RG188, 13in
 CA-451A SMA-SMA Plug, RG188, 4.25in
 CA-452A SMA-SMA Plug, RG188, 8in
 CS-565 Female BNC to Female BNC Adapter
 CS-633 Adapter, TRIAX to BNC
 CS-701 BNC Tee Adapter
 CS-1247 SMA Female to BNC Male
 CS-1249 SMA Female to SMB Plug
 CS-1251 BNC Female to SMB Plug
 CS-1252 SMA Male to BNC Female
 CS-1281 SMA Female to SMA Female
 CS-1382 MMBX-to-SMA Adapter
 CS-1390 TRIAX to SMA Adapter, no guard
 CS-1391 SMA TEE Adapter (female, male, female)

DRIVER OPTIONS

4200ICCAP-6.0 IC-CAP Driver and Source Code for 4200-SCS:
 UNIX/Windows

ADDITIONAL CABLES³

236-IIC-3 Interlock Cable, 3m (one included with each 4200-SCS)
 237-ALG-2 Low Noise Triax Cable, 2m (terminated with a 3-slot male triax connector on one end and 3 alligator clips on the other)
 4200-MTRX-1 Ultra Low Noise SMU Triax Cable, 1m (Mini Triax-Triax, connects 4200 SMUs to a test fixture)
 4200-MTRX-2 Ultra Low Noise SMU Triax Cable, 2m (Mini Triax-Triax, connects 4200 SMUs to a test fixture, two included with each 4200 SMU that is not configured with a Remote PreAmp)
 4200-MTRX-3 Ultra Low Noise SMU Triax Cable, 3m (Mini Triax-Triax, connects 4200 SMUs to a test fixture)
 4200-PRB-C SSMC to SMA Cable with local ground
 4200-RPC-0.3 Remote PreAmp Cable, 0.3m (for use inside prober shield)
 4200-RPC-2 Remote PreAmp Cable, 2m (for remote location of 4200-PA, one included with each 4200-PA)
 4200-RPC-3 Remote PreAmp Cable, 3m (for remote location of 4200-PA)
 4200-RPC-6 Remote PreAmp Cable, 6m (for remote location of 4200-PA)
 4200-TRX-0.3 Ultra Low Noise PreAmp Triax Cable, 0.3m, (Triax-Triax, connects 4200-PA to a test fixture, recommended for remote location of the 4200-PA)
 4200-TRX-1 Ultra Low Noise PreAmp Triax Cable, 1m, (Triax-Triax, connects 4200-PA to a test fixture)
 4200-TRX-2 Ultra Low Noise PreAmp Triax Cable, 2m, (Triax-Triax, connects 4200-PA to a test fixture, two included with each 4200-PA)
 4200-TRX-3 Ultra Low Noise PreAmp Triax Cable, 3m, (Triax-Triax, connects 4200-PA to a test fixture)
 7007-1 Double Shielded IEEE-488 Cable (1m)
 7007-2 Double Shielded IEEE-488 Cable (2m)
 CA-19-2 Cable Assembly
 CA-426B TRIAX to SSMC Cable Assembly
 CA-446A SMA Cable, 100Ω, 3m
 CA-447A SMA Cable, male to male, 100Ω, 1.5m

OTHER ACCESSORIES

4200-CART Roll-around Cart for 4200-SCS
 4200-CASE Transport Case for 4200-SCS
 4200-MAN Printed Manual Set for 4200-SCS
 (Manual on CD-ROM is included in Base Unit)
 4200-Q-STBL-KIT Stabilization Kit for 4200-PIV-Q
 4205-PCU Pulse Combiner Unit
 4205-RBT Remote Bias Tee
 EM-50A Modified Power Splitter
 TL-24 SMA Torque Wrench

NOTES

1. 4200-MAG-BASE is included with 4200-PIV-A Remote Bias Tees.
2. Also fits 4200-PIV-A Remote Bias Tees.
3. All 4200-SCS systems and instrument options are supplied with required cables (2m length).

1.888.KEITHLEY (U.S. only)

www.keithley.com

KEITHLEY

4200-SCS

Semiconductor Characterization System



Integrated industrial controller and additional RAM ensure high test throughput, plus system robustness, stability, and security.

Industry-standard Windows-based GUI minimizes set-up and integration time.

High speed, high precision ADC per channel eliminates performance tradeoffs.

Store test setups and results right on the system with the high capacity fixed disk drive. No sorting through floppy disks to find the desired test.

The integrated CD-RW drive allows high capacity backup and data transfer.

Communicate quickly with a wide range of PC accessories with the built-in USB interface.

The 4200-SCS can be rack mounted. It has the same dimensions and occupies the same rack space as semiconductor parametric analyzers that may already be in use.

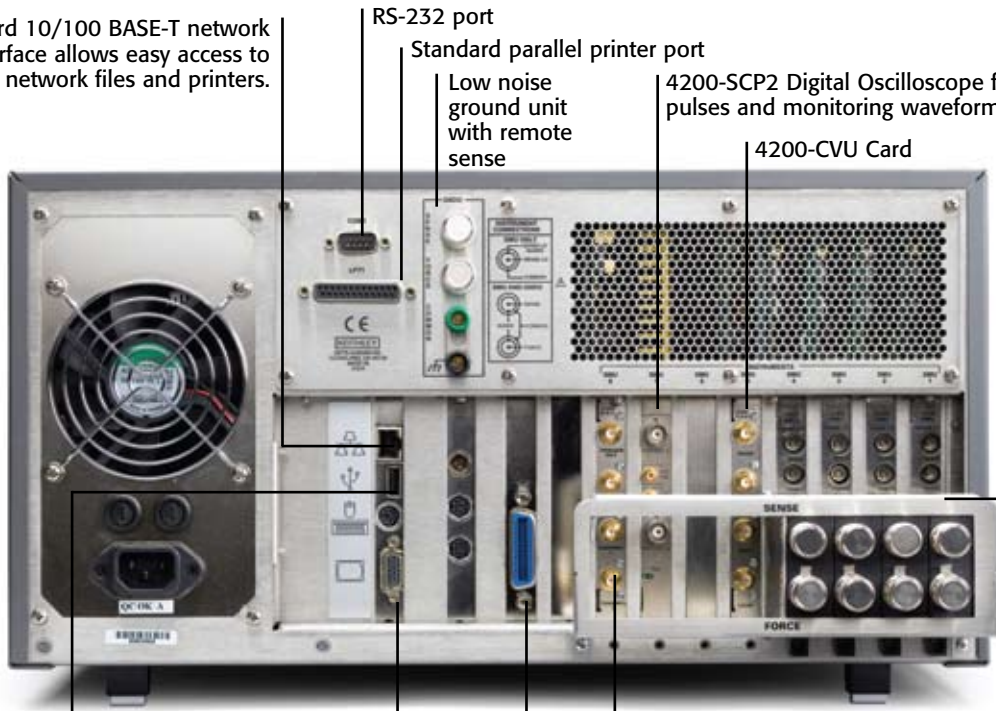

Standard 10/100 BASE-T network interface allows easy access to network files and printers.

RS-232 port

Standard parallel printer port

Low noise ground unit with remote sense

4200-SCP2 Digital Oscilloscope for measuring pulses and monitoring waveforms

4200-CVU Card

Configurable with from 2 to 8 SMUs and optional sub-femtoamp Remote PreAmps. Adding high power SMUs won't restrict SMU capacity.

SVGA monitor port

Additional USB 1.1 port

Dual-channel pulse generator supports pulse I-V testing and other pulse applications.

Use the GPIB interface to control external instruments or to allow external control of the 4200-SCS using an Agilent 4145 style command language.

Model 4200-SCS technical data

SEMICONDUCTOR

1.888.KEITHLEY (U.S. only)
www.keithley.com

KEITHLEY

A GREATER MEASURE OF CONFIDENCE

4200-SCS

Semiconductor Characterization System

PreAmp Mounting and Cabling



It's easy to connect the Model 4200-SCS to a probe station or a switch matrix with standard triax cables.



PreAmps can be mounted on the probe station with either a platen base or a triax mounting bracket. By reducing the signal path between the DUT and the PreAmp from several feet to a fraction of an inch, the Model 4200-SCS can eliminate cable effects like parasitic capacitance and leakage currents, for more accurate low-level measurements.

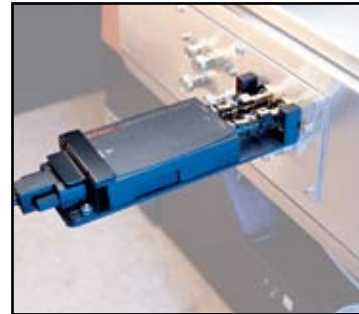

An optional vacuum (Model 4200-VAC-BASE) or magnetic (Model 4200-MAG-BASE) platen mounting base allows the PreAmp to be located next to manipulators on the chuck platen, eliminating measurement problems caused by long cable lengths when performing ultra-low current measurements.

If platen space is not available, the triax mounting bracket (Model 4200-TMB) allows users to locate the PreAmp on dual triaxial connectors that may already be installed for HP4156 Kelvin triax cables. This mounting option reduces problems caused by long cables without occupying platen space.

4200-SCS

Semiconductor Characterization System

4200-SCS Accessories



Model 4200-CAB-XXX
Cabinet



Model 4200-CART
Roll-around cart



Model 4200-CASE
Transport case



Model 4200-KEY-RM
Keyboard rack mount



S J ELECTRONICS
POWER • TEST & MEASUREMENT

0800 583 44 55

Tel: +44 1536 416 200
Fax: 0800 583 55 66
sales@sjelectronics.co.uk
www.sjelectronics.co.uk

1.888.KEITHLEY (U.S. only)

www.keithley.com

KEITHLEY

A GREATER MEASURE OF CONFIDENCE