

Multiplex Scanner Box GSB-01

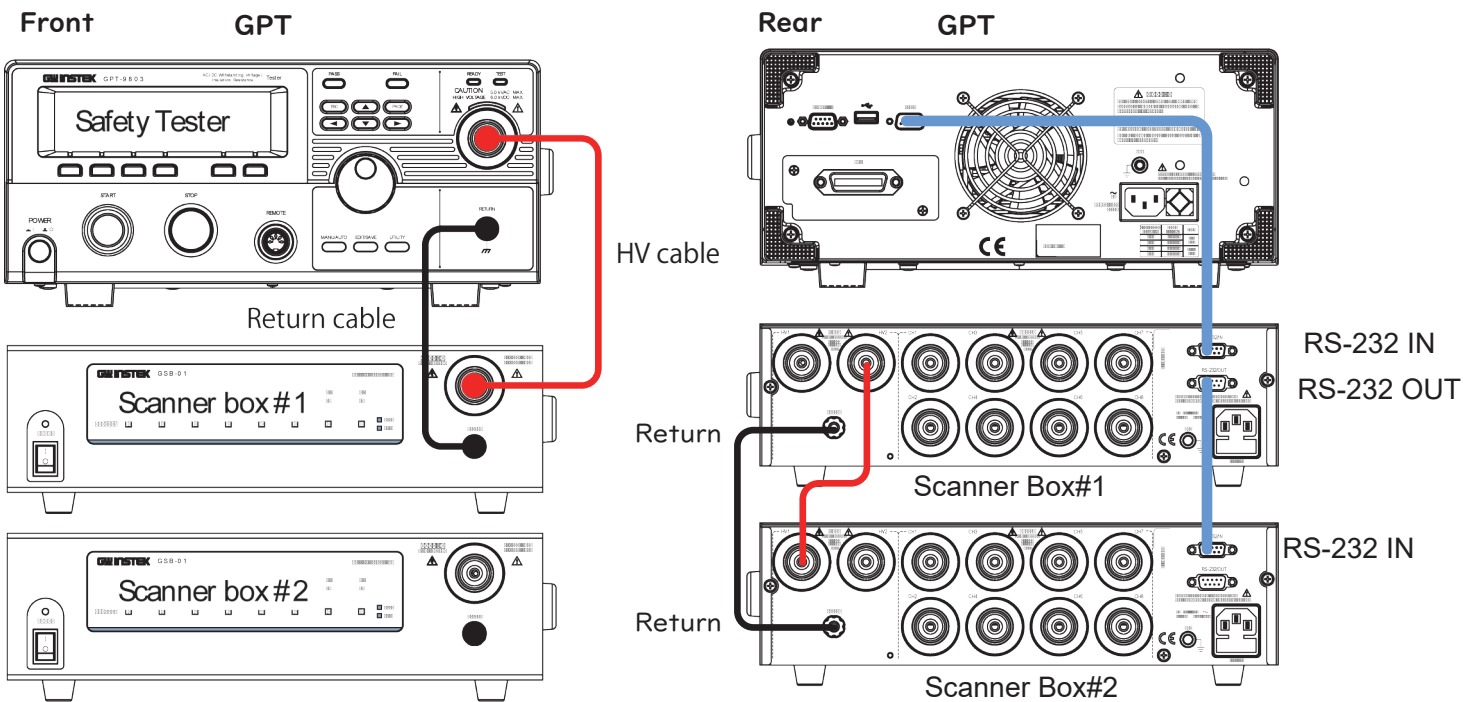

IR, ACW, DCW connections with common return terminal. These tests are best performed sequentially. GHT-116R and GHT-116B test leads are to be used.

IR, ACW, DCW connection with separately configured HI & LO terminals. GHT-116R and GHT-116B test leads are to be used.

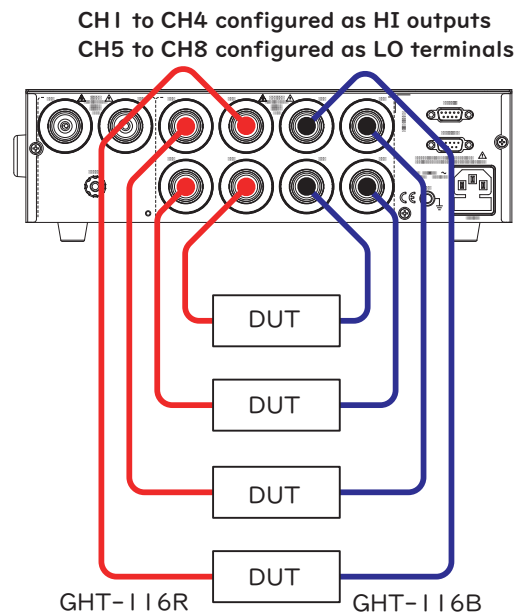
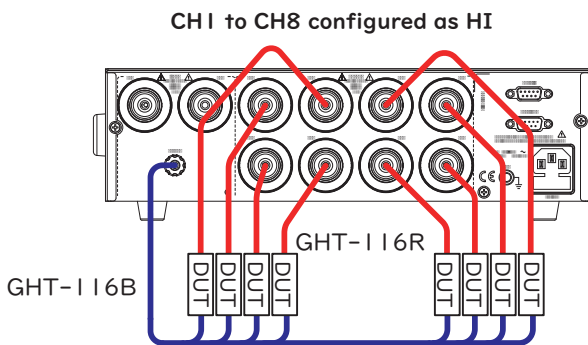

GSB-01 Standewrd Accessories:

GTL-235×1 Communication Cable

GHT-108 H.V.×1

GHT-116R ×8

GHT-116B ×1



GSB-01×2 :

GHT-116R × 16

GHT-116B × 2