

# LAND

## AMETEK®

*CRITICAL MEASUREMENTS  
IN CEMENT MANUFACTURE*

**APPLICATION NOTE**



Portland cement is an essential ingredient for the construction industry, used to make concrete and mortar. There are more than 2,300 active cement plants around the world producing over 3.9 billion tonnes per year. They produce cement by heating crushed limestone and other ingredients in a rotary kiln to produce clinker which is milled to a fine powder to manufacture the finished product.

Temperature monitoring across the manufacturing process is essential to support process efficiency and cement product quality. It can also help to prolong the life of the kiln through early detection of refractory issues or insufficiently quenched clinker, which could lead to production stoppages if left unchecked. Monitoring solutions also support safety and emissions control.

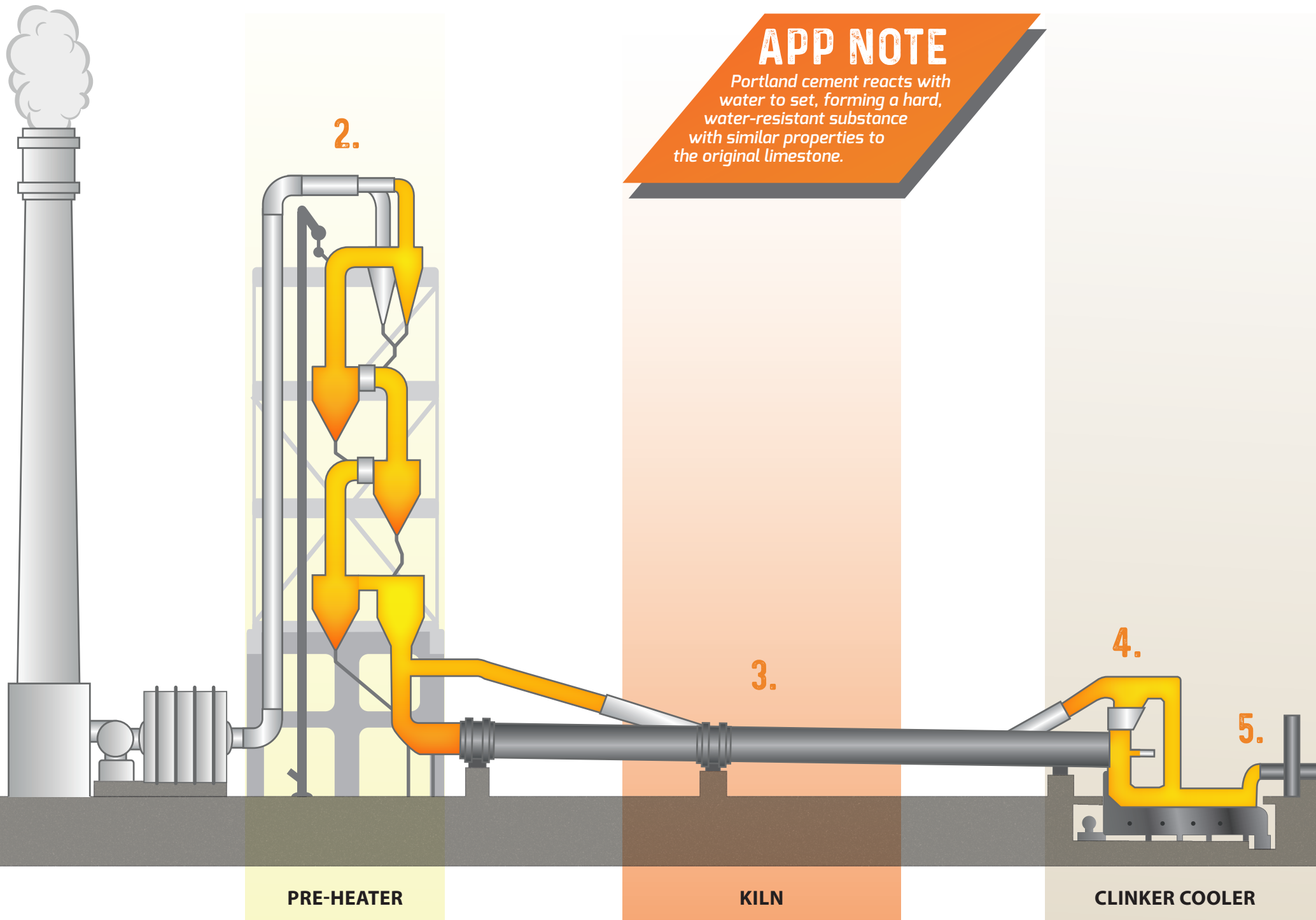

## APP NOTE

Portland cement reacts with water to set, forming a hard, water-resistant substance with similar properties to the original limestone.

# THE CEMENT MANUFACTURING PROCESS

Cement is created by heating crushed limestone with clay, slate, blast furnace slag and other materials, then cooling and grinding the resultant clinker to create a fine powder.

Most modern cement plants use a dry process which is more thermally-efficient than the older wet process. The process consists of the following stages:

1. Quarried limestone is crushed along with clay, slate, blast furnace slag and other components, to a size of 75 mm (3 in.) or less.
2. The raw materials are heated in the multi-stage pre-heater and then fed into a rotary kiln which raises their temperature to approximately 1370 °C (about 2500 °F).
3. As they progress along the rotary kiln towards the firing zone, the raw materials lose moisture and other components and form a rock-like substance called clinker, mineral lumps roughly 25 mm (1 in.) in diameter.
4. Upon leaving the kiln, the hot clinker is cooled, and the heat is recycled to the pre-heater. This improves efficiency, saves money and reduces the environmental impact of the process.
5. The cool clinker is milled to form a fine powder, and any additional cement components – for example, calcium sulphate to control the setting time – are added.
6. The finished cement is bagged and shipped.

## TEMPERATURE MEASUREMENT POINTS

Temperature monitoring at key stages is critical for the close control of the manufacturing process, ensuring process efficiency, consistent product quality, and prolonging the life of the kiln.

The important points for these measurements are in and around the rotary kiln, measuring:

- The burning zone
- The kiln shell
- The clinker cooler

## THE ROTARY KILN

The rotary kiln is the key component in a cement plant. It is a long steel cylinder, lined with refractory brickwork to protect the outer shell from the very high temperatures of the interior.

Rotary kilns vary in size and typically have a ratio of length to width of 30 or 40:1. They can be very large, up to 4 m (12 feet) in diameter and up to 160 m

(~524 ft) long. Rotation speeds are in the order of three to five times per minute.

As the kiln rotates, the cement material works its way down towards the burning zone, heating up as it does so. This arrangement means that temperatures may vary considerably within the kiln, making monitoring more difficult.

## THE BURNING ZONE

Also known as the firing zone, the burning zone is at the lower end of the rotary kiln, where the cement components are heated to about 1300 to 1450 °C (2372 to 2642 °F), forming clinker. Accurate temperature measurements are critical for product quality, environmental performance and kiln lifetime.

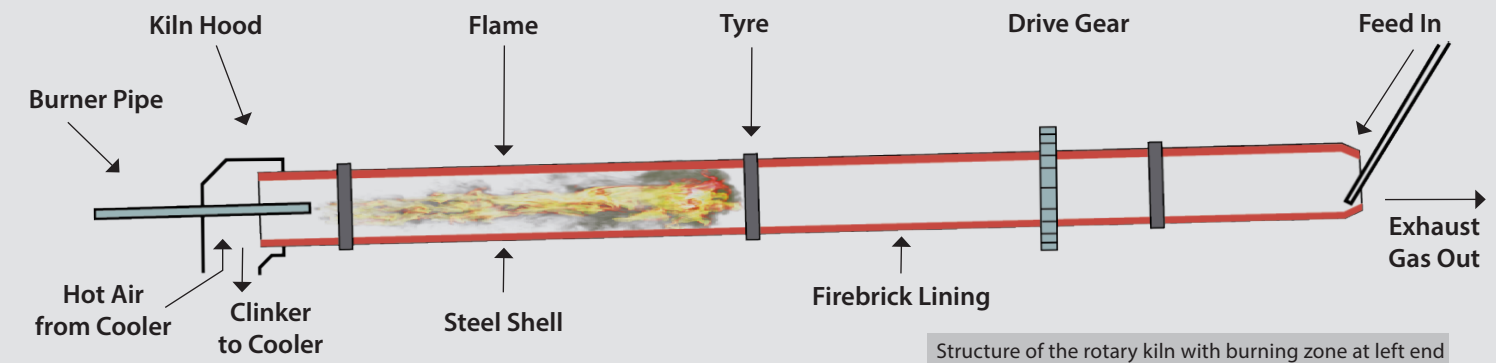

Structure of the rotary kiln with burning zone at left end

# TEMPERATURE SOLUTIONS INSIDE THE KILN

## CHALLENGES OF BURNING ZONE TEMPERATURE MEASUREMENTS

The inside of a cement kiln is an extremely challenging environment for making any kind of temperature measurement. Kiln rotation, high temperatures, and the movement of the sintering material along the kiln, make thermocouples and other contact-based temperature sensors impractical.

Radiation thermometers, or pyrometers, allow a non-contact temperature measurement, but their effectiveness can be limited by the high-dust conditions within the burning zone and small target point within a large, dynamic kiln area.

Nevertheless, the temperature at the burning zone, the hottest part of the process, is an important measurement, because it shows whether or not there has been a complete transformation from DiCalcium Silicate (C<sub>2</sub>S) to

TriCalcium Silicate (C<sub>3</sub>S), a process which occurs at around 1300 to 1450 °C (2372 to 2642 °F).

Ratio pyrometers are often used to measure temperatures in the burning zone, as they are much less susceptible to errors caused by obscuration and dust.

Combined with a peak-picker algorithm, a ratio thermometer can give an accurate temperature measurement even when there is 95% obscuration in the field of view.

This provides an effective measurement for general monitoring but does not supply much information about the kiln operation. Only a single measurement value from a small part of the kiln is provided, and so the readings can be deceptive if the target area is not optimised.

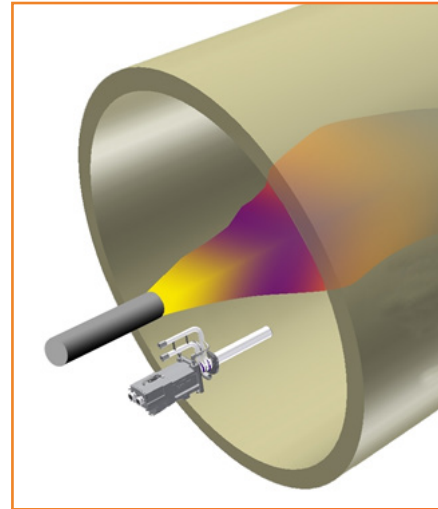

The MWIR-B-640 provides not only temperature measurement in the burning zone but also a live video view of the conditions within the kiln.

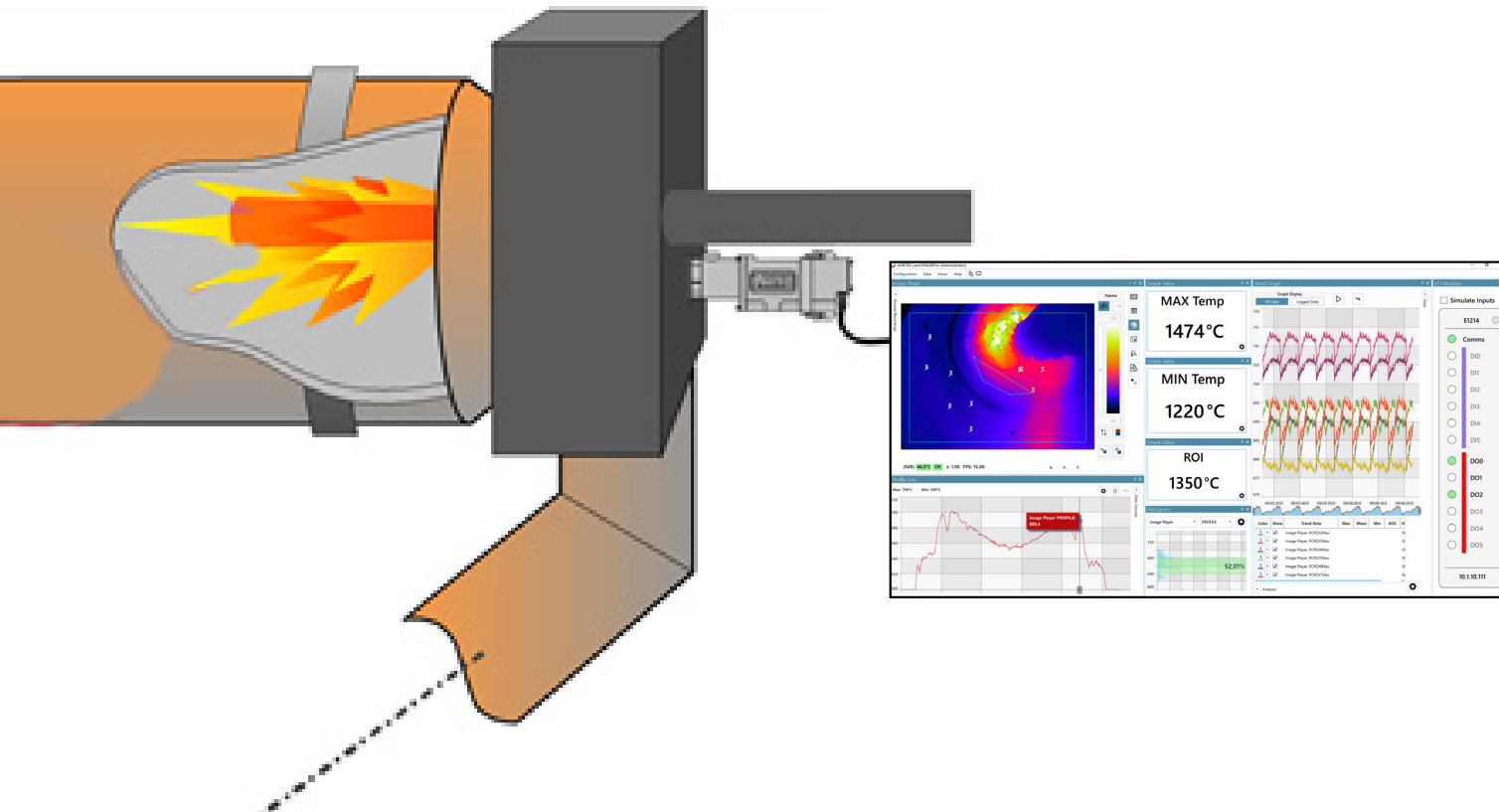

A thermal imager installed for burning zone measurements.

# RECOMMENDED PRODUCT:

## MWIR-B-640



THERMAL IMAGING

### ELECTRICAL AUTO-RETRACT (AR) SYSTEM

Designed to auto-retract and protect the thermal imager from damage by overheating in the event of loss of water flow, air pressure, electricity supply or high borescope tip temperature alarm.

## ALTERNATIVE PRODUCT: NIR-B-2K

### FEATURES

- Suitable for gas fired kilns
- 3,000,000 pixel resolution



The mid-infrared wavelength radiometric borescope camera is specifically designed to measure temperature profiles in furnace interiors.

Producing detailed live images with over 300,000 pixel resolution, the MWIR-B-640 allows the operator to select from thousands of live data points for highly specific optimisation. In the high-particulate environment of the rotary kiln, it provides a clear image of the kiln interior.

With a wide field of view (FOV), the MWIR-B-640 requires only a narrow hole through the firing hood. High-performance water-cooling allows it to operate in hot environments, while an auto-retraction system can be used to remove the instrument from the kiln if the cooling system fails.

### FEATURES

- High sensitivity mid-wave IR sensor
- Rugged design
- Water cooled & air purged
- Fail-safe retraction system
- Works with ImagePro software

### BENEFITS

- 'See-through' luminous flames
- Optimum process control
- High accuracy and repeatability
- Assured – fail safe protection and 12 month warranty

# THERMAL IMAGING SOFTWARE: IMAGEPRO

The innovative IMAGEPro is an advanced image processing software for controlling, monitoring, analysing and capturing imager data for extensive testing.

Able to monitor and control up to sixteen imagers, IMAGEPro offers real-time analysis giving users exceptionally detailed control over their thermal imaging.

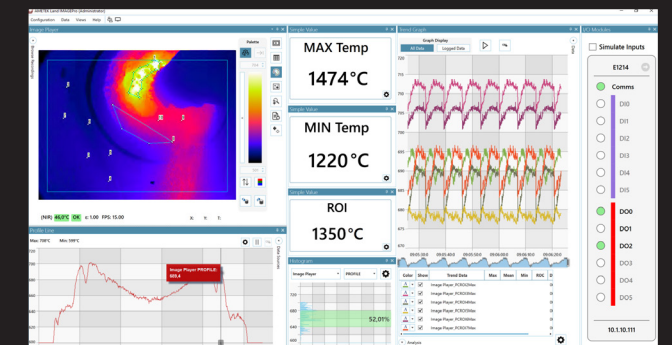

## ADVANTAGES OF USING A THERMAL IMAGER FOR KILN MEASUREMENTS

To obtain more detailed process information about the kiln, a more modern approach is to use a thermal imager, with a mid-infrared sensor and borescope lens.

This provides much more information about conditions within the burning zone. Borescopes have been used for many years for inspection and diagnostic purposes, but in recent years infrared versions, such as AMETEK Land's MWIR-Borescope-640 (MWIR-B-640) camera has been developed for thermal imaging applications.

As is the case with ratio pyrometers, the borescope requires air purge and water cooling to protect it from aggressive environmental and process conditions.

The MWIR-B-640 probe is only 61 mm (2.4 in.) in diameter, including the water-cooled jacket, so can be inserted through a small viewing port without any major disruption to the process.

Because the kiln rotates continuously, the clinker collects on one side. This allows the borescope to be installed under the burner towards the opposite

side, providing sighting onto the clinker and flame.

To minimise exposure to process conditions, the tip of the borescope is usually slightly recessed into the wall. This does not affect its function, and the large 90° x 67.5° field of view enables it to form an image of all the relevant parts of the process.

The MWIR-B-640 produces a detailed, live radiometric image, with accurate temperature information that allows the operator to measure any subset of over 300,000 live data points.

The wide-angle image, with high spatial resolution, allows accurate temperature measurements and important information about the process conditions within the burning zone.

The image processing software provided with the MWIR-B-640 can be configured to measure multiple regions of interest and, as with a ratio pyrometer, defining up to 100 regions of interest in the thermal field of view, the process minimum, average and maximum temperature readings can

be monitored at different areas within the image to control the process, whilst having a contentious view into the process 24/7.

The thermal image provides important data about kiln condition and qualitative information such as flame propagation and formation of ash rings within the kiln.

The mid-infrared wavelength used by the MWIR-B-640 provides a clear view through radiant flames and minimizes the effects of scattering, providing a much clearer view of the process than visible or short-wavelength infrared imagers.

This makes it particularly valuable, as it can accurately measure temperature and provide high-quality process imaging simultaneously.

An automatic retraction system provides protection for the borescope in the event of a temporary loss of purge air or cooling water. This system withdraws the entire instrument from the process if an air or water failure is detected.

## THE BENEFITS OF KILN INTERIOR MONITORING

Kiln temperatures are very high, particularly at the burning zone where they typically reach 1300 to 1450 °C (2372 to 2642 °F). To protect the outer steel shell of the kiln from heat damage, layers of refractory brick are used.

However, with repeated use under high-heat and abrasion conditions, the refractory will eventually deteriorate and fail.

A deteriorating kiln lining can significantly affect fuel costs, as

heat loss increases as the refractory insulation deteriorates. It can also lead to damage of the outer shell, putting the kiln out of action.

While it is important to monitor the kiln exterior temperature (see page 08), thermal imaging of the kiln interior can also provide an early indication of damage to the refractory lining.

The detection of kiln damage is key to ensuring timely maintenance, extending the kiln's lifespan.

It also allows proactive maintenance to be scheduled to minimise downtime and interference to cement production operations.

An infrared thermal imager such as the MWIR-B-640 offers a clear, real-time view of the kiln refractory surface, enabling any deterioration to be identified and located easily. Compared with conventional video cameras, this view is far less likely to be adversely affected by the heavy dust levels in the kiln.

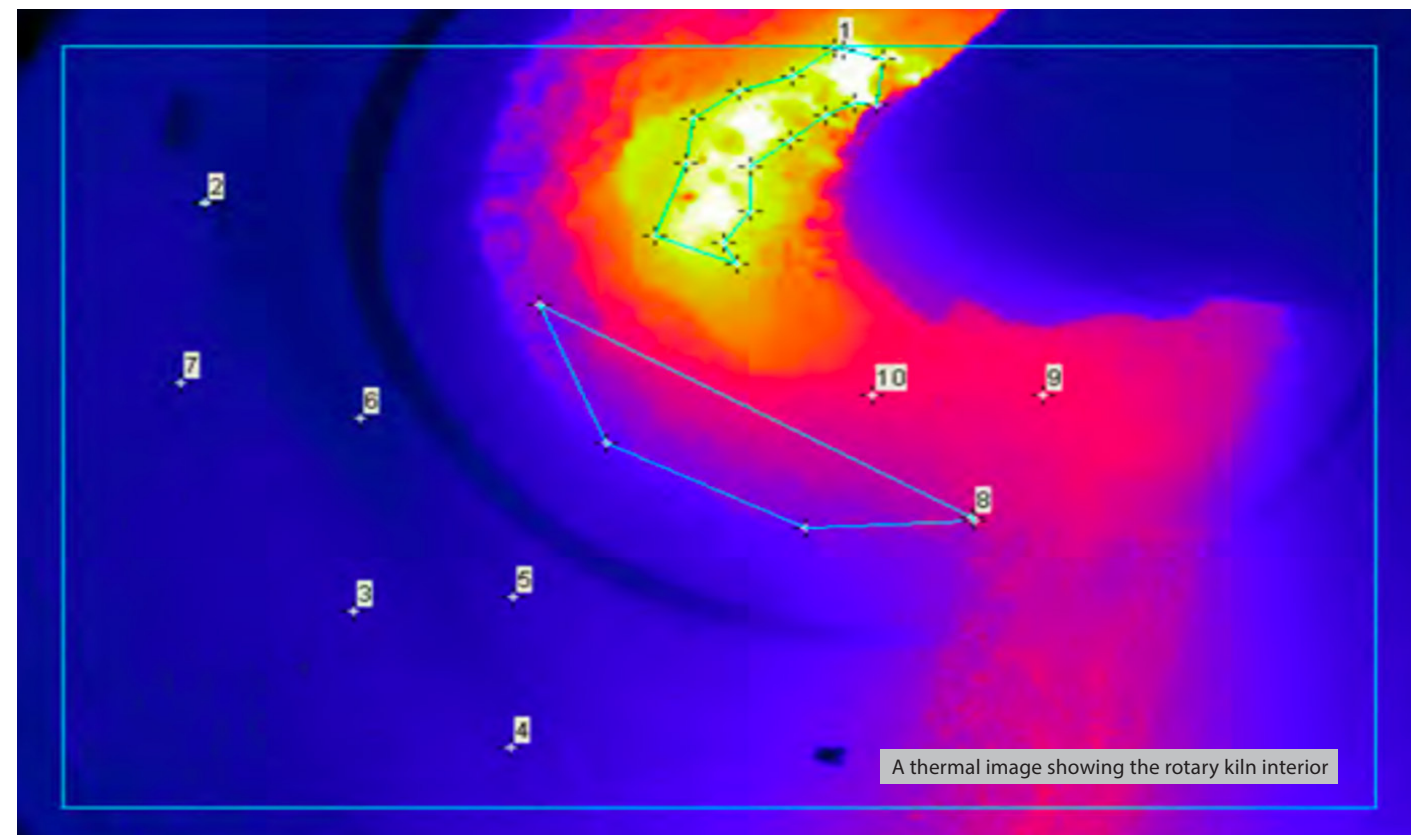

## ALTERNATIVE PRODUCT:

### SPOT R100



FIXED SPOT PYROMETERS

This ratio thermometer with peak picking function allows measurement in dusty environments of up to 95% obscuration.

Quick and easy to install, the SPOT range provides a complete solution with integrated signal processing. Flexible connections via Ethernet, Modbus TCP, and 4-20 mA analogue allows alarm outputs and video streaming.

The SPOT range integrates sophisticated automatic beam alignment technologies that precisely focus the advanced infrared optics. This enables it to deliver accurate stable measurements quickly, reducing maintenance time and enabling faster process adjustments.

### FEATURES

- Integrated solution – onboard processing
- Digital and Analogue outputs
- Local and remote motorised focus control
- Easy plug-and-play installation

### BENEFITS

- Ratio version with peak picker able to measure in high dust
- No separate processor required
- Ultra scratch-resistant sapphire protection window
- Integrated webserver for easy access

# KILN SHELL MONITORING

Monitoring the exterior kiln shell temperature is critical. The steel kiln shell is protected from the extremely high process temperature by one or two layers of refractory brickwork. If this brickwork fails, either by erosion

or physical loss of bricks, the metal shell can be severely damaged, putting the kiln out of action. Detecting hot spots indicative of refractory damage helps to avoid costly maintenance or unplanned shutdowns.

Continuous monitoring along the length of the kiln provides early detection of problems, allowing for repairs to be made before serious damage occurs.

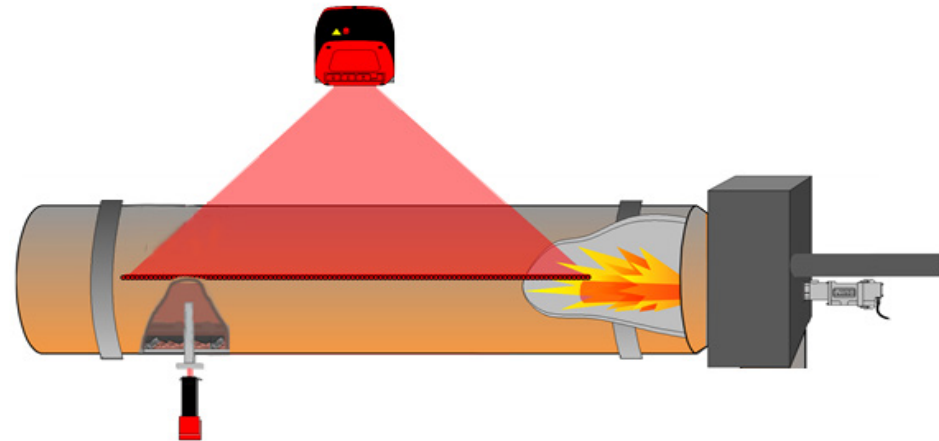

A linescanner installed to monitor the kiln shell exterior

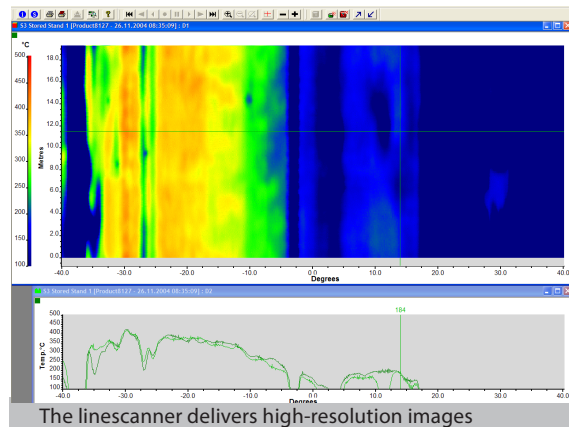

The linescanner delivers high-resolution images

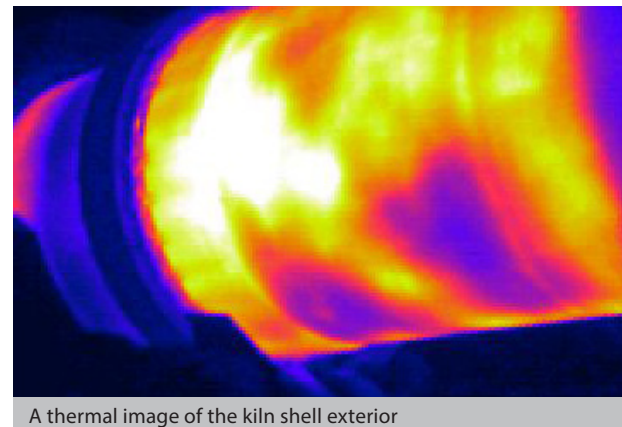

A thermal image of the kiln shell exterior

## TEMPERATURE SOLUTIONS IN THE KILN SHELL

Traditionally, thermocouples have been used to take temperature measurements along the moving kiln. However, these give poor coverage and are unreliable.

A better measurement is provided by non-contact technologies, and a common method is to use a handheld, portable pyrometer to measure repeatedly along the rotating kiln. However, this method is very labour-intensive, and is not very effective, as it does not provide full coverage of

the kiln shell. The measurement also depends on the operator's skill and judgement, so repeatability is poor, particularly when different people make the measurement.

A more effective technique is to use a linescanner to map the temperature of the outer shell resulting in a high resolution thermal image. AMETEK Land's solution for this application is the LSP-HD 62, a compact, highly homogenous linescanner designed to produce

high-accuracy thermal images of moving processes.

Installed to view the rotating kiln with an 80° scan angle, it samples 1,000 points along a single line, up to industry-leading scan speeds of 150 Hz. This helps build up a picture of the complete shell temperature, identifying any aberrations. For long kilns, multiple scanners can be used – AMETEK Land's proprietary Landscan WCA software will unify the data from these scanners to form one overall picture of the kiln temperature.

# RECOMMENDED PRODUCT:

## LSP-HD 62



LINESCANNING

Designed to operate in harsh environments, the LSP-HD uses high-quality optics to produce high-definition thermal images at unrivalled scan speeds, for outstanding process control.

All LSP-HD scanners feature rugged sapphire protection windows that resist scratches, acids and solvents. They also have a robust scanner assembly with only one moving part, and a die-cast housing water cooling and air purging.

The LSP-HD 62 is optimised for cement manufacturing applications, with a temperature range from 100 to 600 °C (212 to 1112 °F). A plug-and-play industrial Ethernet connection provides real-time processed data, which is unaffected by ambient light enabling refractory problems to be identified and analysed quickly.

### FEATURES

- High-resolution and very homogeneous optical system
- Integrated kiln alignment and tire slip monitoring
- Operates in hot, dusty industrial environments
- Range of data output formats

### BENEFITS

- Real-time high resolution thermal images for accurate results
- Industry-leading scan speeds
- Detects even the smallest temperature differences
- Installation costs significantly reduced

## USING A THERMOWELL

It is also possible to measure the temperature inside the kiln, away from the burning zone, using a SPOT M160 thermometer and a thermowell.

A thermowell is a closed-ended tube that goes through the wall of the kiln and the refractory. The SPOT thermometer is set up to sight onto the end of the tube. Each time the kiln rotates, the SPOT M160 is able to take a measurement of the temperature at the end of the thermowell.

Because the thermowell is a closed-ended tube, it acts in a similar way to a theoretically ideal cavity radiation source. This means that emissivity is not an issue for the thermowell material and provides an accurate determination of the temperature inside the kiln at that point.

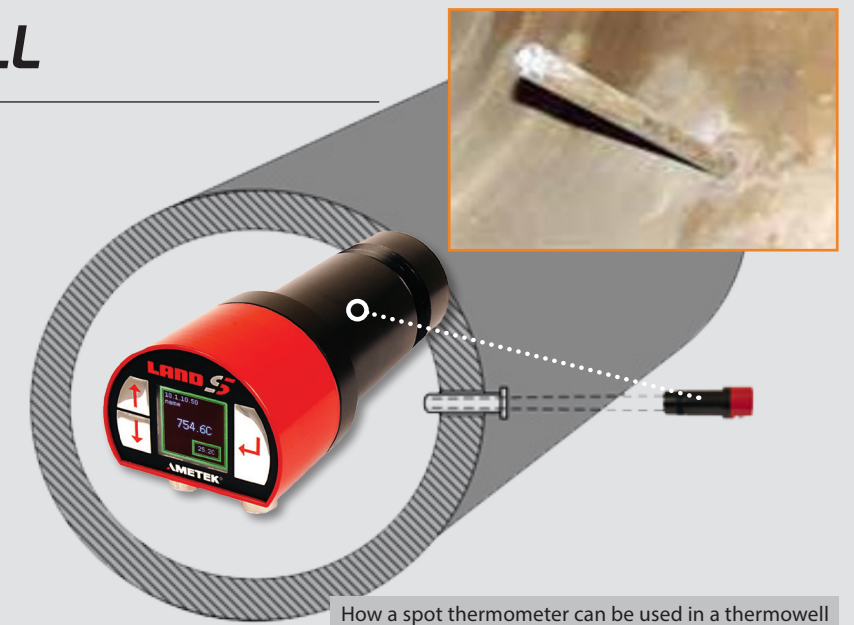

How a spot thermometer can be used in a thermowell

# MONITORING AXIAL ALIGNMENT

Axial alignment is key to trouble-free operation of a rotary kiln. Dislocation from a central position is an indicator of out of tolerance stresses on the system, which can lead to structural damage to the kiln and mechanical parts, and significant cost via lost production.

The axial alignment may change due to kiln shell damage or wear, uneven

wear of the tires and rollers, and incorrect roller positioning.

Monitoring changes in axial alignment not only prevents further damage to the kiln, but also provides an indicator of developing problems, allowing them to be dealt with before an unscheduled shutdown is required. Optional scanner accessories can be

incorporated into the LSP-HD's LANDSCAN WCA scanner software to enable tracking of kiln axial alignment for easy reference of kiln health and performance.

The system uses rugged proximity switches integrated with the scanner input to give readings and alarm outputs as required.

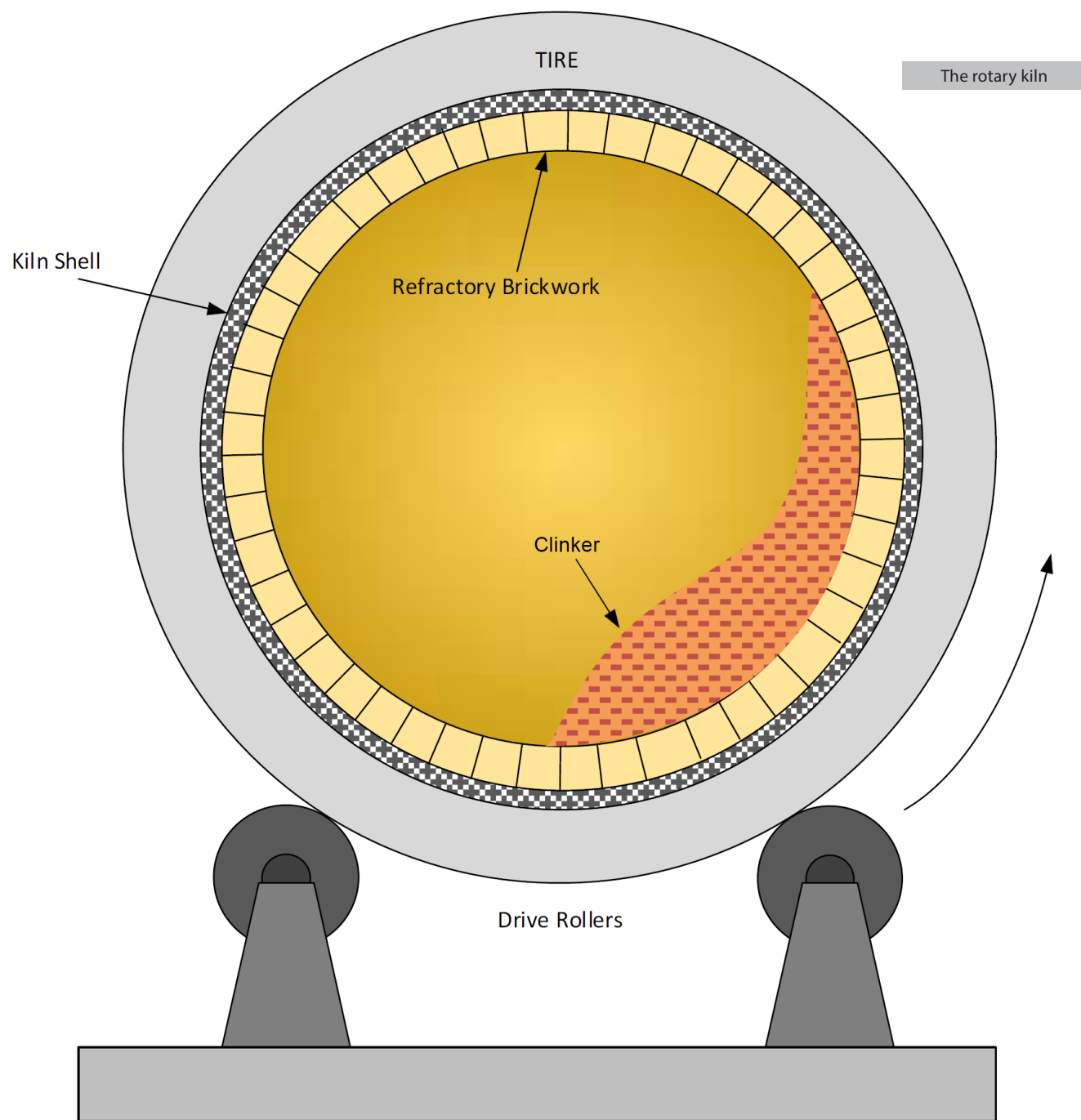

# MONITORING TIRE SLIP

The riding rings that support the kiln shell during rotation are commonly known as tires.

These tires must accommodate thermal expansion as the shell heats up during the manufacturing process. Undue constriction by the tire can damage the shell.

To avoid this, the tire must be loose around the shell, which expands to fit more snugly as the kiln rotates. A tire which is too loose will provide insufficient shell support, that can flatten out at the top of its rotation. Continuous changes in kiln curvature will ultimately damage the integrity of the shell structure.

Typically, the revolution of a tire is slower than that of the shell, by a small but measurable amount which is known as 'creep' and can be seen over time.

Measuring the tire slip can therefore ensure that the tire dimensions are within acceptable limits – a rotation which matches the kiln speed indicates that the tire is too tight, while one that takes too long indicates a fit that is too loose and could result in kiln damage.

Optional position sensors allow the LSP-HD's LANDSCAN WCA server to calculate and display kiln tire slip measurements alongside the kiln temperature, further reducing the likelihood of refractory damage.

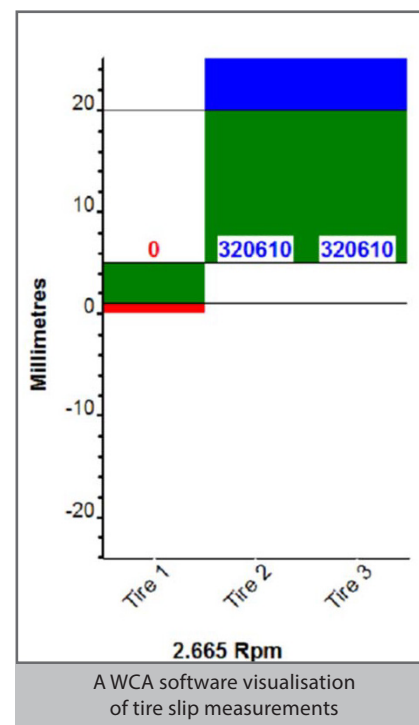

The system uses rugged proximity switches integrated with the scanner input to give customisable readings and alarm outputs as required.

# RECOMMENDED PRODUCT:

## LANDSCAN WCA SOFTWARE

A flexible PC control interface designed specifically for the LSP-HD linescanner range, the LANDSCAN Windows Control and Analyse (WCA) software package enables the viewing and analysis of multiple live and historical temperature data streams.

It supports up to eight LSP-HD linescanners simultaneously, providing detailed analysis and control. It also offers display and analysis of data from multiple LANDSCAN Head and Saved data file combinations, offering versatile data processing options adaptable to your application needs.

With fully scalable input/output capabilities to meet precise application requirements, the tagging and linking of multiple live data streams enables Production Process databases to be created with ease.

Easy to configure, LANDSCAN WCA brings advanced, high-resolution thermal imaging data to a wide range of industrial applications.

### FEATURES

- Plug and play compatibility with LSP-HD range
- Can be scaled to meet application needs
- Supports multiple linescanners
- Live and historical data views

### BENEFITS

- Easy to use, Windows-based system
- Flexible communications options
- Simultaneous display and processing
- Supports multiple workstations

# CONVEYOR SAFETY

Conveyors are used for two reasons in this process. Firstly, they transfer coal from storage piles to the coal mill, where the coal is powdered before being burned to heat the kiln.

Secondly, they are used to move clinker – solid lumps of cement – out of the rotary kiln ready to be cooled and milled into powder.

In both cases, it is essential to monitor the conveyor system for any rogue hot inclusions that could damage the conveyor belt.

A HotSpotIR sensor installed to scan the conveyor

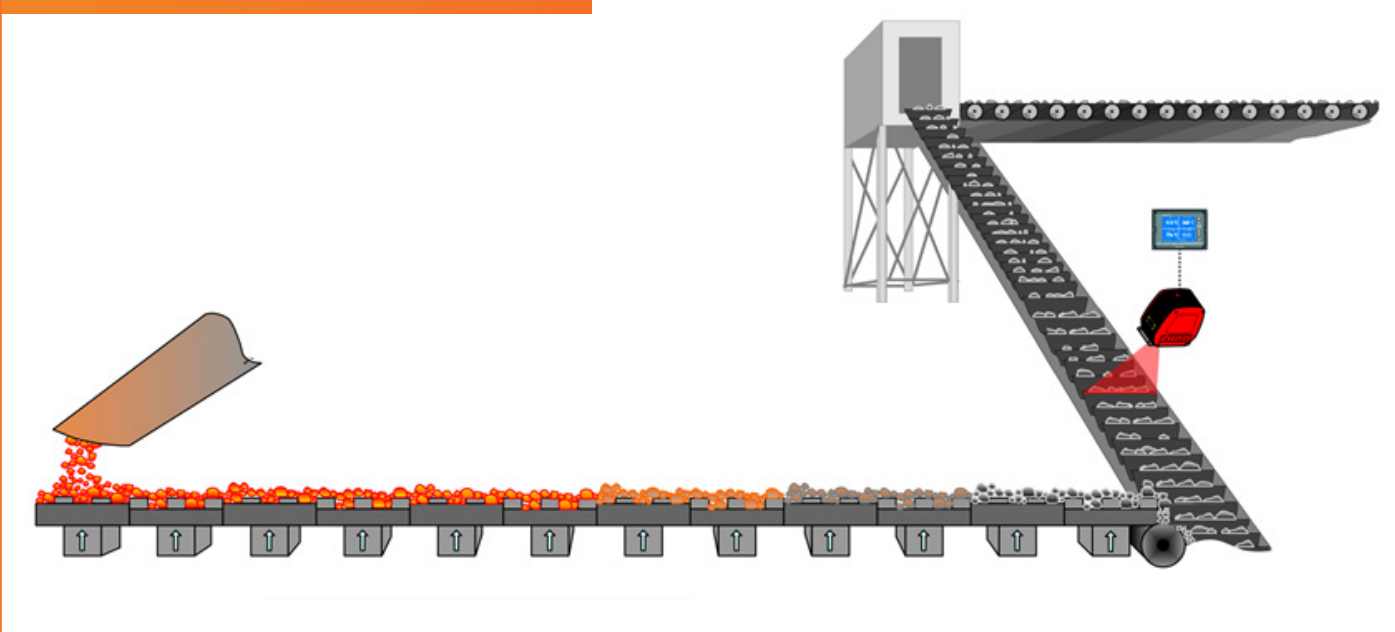

## HOW IT WORKS | TEMPERATURE SOLUTIONS FOR CONVEYOR SAFETY

Even very small fragments of coal or clinker can cause serious problems if they are too hot, damaging the conveyor belt and shutting down the entire manufacturing process.

Single-spot pyrometers won't detect these small hot spots, as they average the temperature over the whole field of view.

Instead, a high-resolution solution is required that can detect a small hot spot with a rapid response. AMETEK Land's HotSpotIR scans the belt at 100 scans per second, detecting 1,000 small temperature spots each time.

This allows detection of any uncooled fragments that pass by, activating a high-speed alarm to alert the operator. Preventative action can then be taken, safeguarding the equipment and avoiding a lengthy shutdown and costly loss of production.

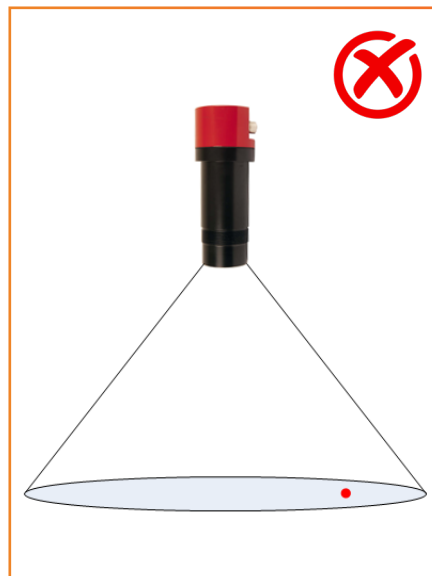

A single-spot pyrometer will average out the whole area it sees, potentially missing small, hot fragments.

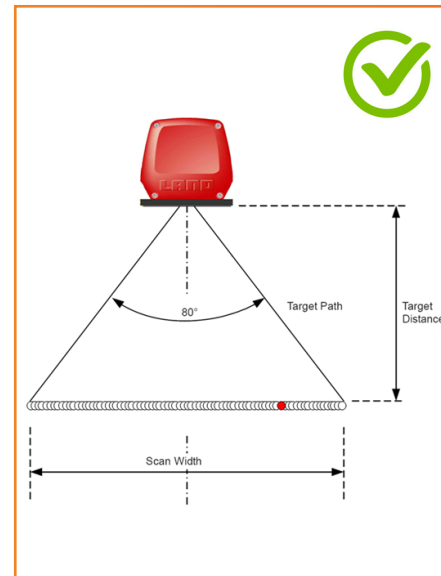

A HotSpotIR scans the belt at 100 scans a second and in each scan it detects 1,000 small temperature spots.

# RECOMMENDED PRODUCT:

## HotSpotIR



LINESCANNING

A compact, fixed-focus, high-speed scanning system, the HotSpotIR is specifically developed to detect hot inclusions on a moving conveyor.

Designed for industrial environments, it rapidly identifies hot particles, preventing damage and avoiding costly shutdowns.

With high-resolution monitoring across 1,000 temperature spots, user-adjustable scanning speed up to 100 Hz, and repeatability of  $\pm 0.5$  °C ( $\pm 0.9$  °F), the HotSpotIR can detect hot spots as small as 25 mm (1 in.).

Easy to install, it uses non-contact infrared scanning to measure across a range from 20 to 250 °C (68 to 482 °F) independent from ambient/sun light.

The HotSpotIR connects to a dedicated processor and measures hot spots across the entire belt surface, activating an alarm which can be set to trigger a fire suppression system or divert the material to a safe location.

The continuous monitoring means hot spots can be detected and the alarm triggered in a hundredth of a second, allowing the operator to respond quickly.

### FEATURES

- Wide scan angle of 80°
- Built-in laser targeting system
- Fast, 100 Hz scanning speed
- Withstands high ambient temperatures

### BENEFITS

- Increases confidence in safety
- Rapid-response alarm system
- Helps reduce insurance costs
- Prevents damage and downtime

## CLINKER COOLER MONITORING

For safety and process management purposes, it can be necessary to monitor the clinker as it leaves the kiln to limit temperature and ensure maximum safety and efficiency.

In many modern processes, the risk of fire is low, but measuring the clinker temperature at this point also helps to ensure that cooling is taking place effectively, so that heat can be efficiently recycled to the pre-heater.

AMETEK Land offers a choice of solutions for this application: the SPOT pyrometer and MWIR-B-640 thermal imager both provide rapid-response, accurate temperature measurements to detect hot clinker.

### SPOT pyrometer



FIXED SPOT THERMOMETERS

### MWIR-B-640 thermal imager

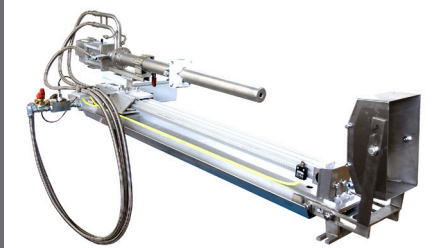

PROCESS IMAGING

# OTHER SOLUTIONS FOR CEMENT MANUFACTURING

AMETEK Land also supplies industry-leading solutions for other applications in the cement manufacturing process. These include:

- Emissions monitoring throughout the process
- Material build-up monitoring at the feed chute and spray tower
- Hot spot and CO detection during the storage, conveying and milling of the coal used for heating
- Flue gas analysis throughout the plant

DOWNLOAD THE CEMENT AND LIME BROCHURE: [WWW.AMETEK-LAND.COM](http://WWW.AMETEK-LAND.COM)

## EMISSIONS MONITORING THROUGHOUT THE PROCESS

The manufacture of cement generates high levels of particulates, including dust, NOx, sulphur dioxide, carbon dioxide and carbon monoxide. These are typically subject to regulation, and so require continuous monitoring and control. However, the high-particulate environment can adversely affect both the measurements and the instrument. Overcoming this challenge to successfully and continuously measure particulate emissions means that cement plant operators are able to ensure they meet control regulations and avoid the prospect of large fines. It can also improve operational efficiency leading to lower costs.

### KEY SOLUTION | 4500 MkIII

A high-specification opacity and dust monitor, the accurate, reliable 4500 MkIII meets European standards for monitoring combustion processes.

It uses a highly homogenous LED light source to minimise sensitivity to optical misalignment, and a multi-prism retro-reflector which reduces thermal drift, providing the lowest possible detection limit.

Together with a flood LED to minimise electronic drift, these patented technologies provide highly stable, highly accurate results.



COMBUSTION & EMISSION MONITORING

### OTHER COMBUSTION AND EMISSIONS MONITORING SOLUTIONS

- 4650-PM: For PM-CEMS or PM-CPMS measurements
- Lancom 4: Portable flue gas analyser
- WDG-1200/1210: In-situ oxygen probe for combustion optimisation

FIND OUT MORE AT: [WWW.AMETEK-LAND.COM](http://WWW.AMETEK-LAND.COM)

## EARLY WARNING OF COAL MILL FIRES

Various fuels are used to heat the kiln, including coal, oil and refuse-derived fuel (RDF). Where coal is burned, it must first be ground to a fine powder in a coal mill. Safe operation of the mill requires close attention

to spontaneous combustion and associated risk of explosion. Carbon monoxide (CO) monitoring offers a fast and sensitive method to detect the early stages of spontaneous combustion so that action can be

taken to prevent a fire or explosion. There is very little CO in the mill during normal operation, so a rapid rise in concentration is a clear indication of a problem.

### KEY SOLUTION | MILLWATCH

Delivering a fast, accurate response to increases in CO levels, Millwatch helps to improve process safety, protecting the mill equipment from damage and preventing costly downtime from unnecessary shutdowns.

Using AMETEK Land's unique CO detection system, it continuously extracts sample gases from the mill outlet for constant measurement with a fast response to any changes.

Customisable alarms allow adaptation to individual plant process conditions, while automatic calibration ensures that high measurement integrity is maintained at all times.

The Silowatch CO detector performs the same safety monitoring function for coal storage silos.



COMBUSTION & EMISSION MONITORING

### AMETEK LAND NON-CONTACT MEASUREMENT SOLUTIONS

- LWIR-640: For 24-hour infrared thermal monitoring of storage piles
- Cyclops L: Portable, handheld pyrometer for accurate temperature measurements

### AMETEK PROCESS INSTRUMENTS ANALYSERS

- WDG-HP11: Convection-driven combustion analyser for high particulate conditions
- WDG-VCM with blowback: Flue gas analyser for oxygen, combustibles and hydrocarbons
- WDG-VRM: Rack-mounted oxygen analyser suitable for CEMS integration
- CEM/O<sub>2</sub> Humox: For net oxygen and moisture content measurements

## AMECARE<sup>®</sup> PERFORMANCE SERVICES

Our in-house service centres provide after-sales services to ensure you get the best performance from your system. This includes technical support, certification, calibration, commissioning, repairs, servicing, preventative maintenance and training. Our highly trained technicians can also attend your site to cover planned maintenance schedules and repair emergency breakdowns.



## SUMMARY

Temperature measurements are critical throughout the cement manufacturing process, to ensure consistent cement quality and to prolong the lifespan of the equipment.

Monitoring is focused on the rotary kiln, and there are a number of measurement techniques that are applicable. While single-spot measurements from a ratio thermometer are effective, the most comprehensive information is obtained from thermal imaging.

This provides an overall picture of kiln activity at the burner end, allowing the operator to see a live view of operations in the firing zone and beyond.

A linescanner can help safeguard the kiln shell against damage by detecting compromised refractory brickwork at an early stage. In addition, there are many other points where analysis is effective, including hot spot detection and emissions monitoring.

# AMETEK LAND SOLUTIONS FOR TEMPERATURE MEASUREMENTS IN CEMENT MANUFACTURE:

### MWIR-BORESCOPE-640

Highly accurate radiometric infrared borescope imaging camera with spectral filtering for continuous temperature measurement and furnace profiling applications.



### LSP-HD

Ethernet-controlled compact infrared linescanner, designed to produce advanced thermal imaging in moving processes.



### SPOT PYROMETERS

Fully-featured, high-performance pyrometers for fixed, non-contact infrared spot temperature measurements and a range of process requirements.



### HotSpotIR

Continuous infrared thermal line scanning detects small, hot inclusions on the conveyor, with alarms set to operate an inerting or diverting system to prevent expensive belt or downstream fires.



DOWNLOAD THE BROCHURES AT: [WWW.AMETEK-LAND.COM](http://WWW.AMETEK-LAND.COM)

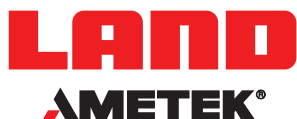

#### CONTACT US



[www.ametek-land.com](http://www.ametek-land.com)



[land.enquiry@ametek.com](mailto:land.enquiry@ametek.com)



APPLIES IN INDIA



APPLIES IN THE UK



APPLIES IN THE US

